

Technical information

Remeha Selecta combi and Selecta system boiler

Remeha Selecta

- High-efficiency condensing boilers for wall mounted installation
- Output: 16 kW (CH)
24 kW (DHW)



 remeha

TABLE OF CONTENTS

Preface	5
1 General requirements	6
2 Appliance introduction	7
2.1 Central Heating Control	7
2.2 Working principle	9
2.3 Combi boiler operation	9
2.4 Advanced boiler control ('abc'- control)	9
3 Dimensions and technical data	10
3.1 Dimensions	10
3.2 Technical details	12
3.3 General Specifications	13
3.4 Optional Accessories	14
4 Installation instructions	15
4.3 Boiler mounting	15
4.3.1 Clearance requirements	15
4.1 General	15
4.2 Boiler positioning	15
4.3.2 Mounting frame	16
4.3.3 Wall bracket	17
4.4 Flue gas discharge and air supply	17
4.4.1 Flue terminal positions	18
4.5 Type of arrangement in connection with flue gas discharge	19
4.5.1 Single boiler, concentric room sealed flue	19
4.6 Installation data	21
4.6.1 Condensate drain	21
4.6.2 Water treatment	21
4.6.3 Safety valve discharge	22
4.6.4 Expansion vessel	22
4.6.5 Circulation pump	23
4.6.6 Heating Water flow	24
4.6.7 Water connections	24
4.6.8 Filling the system/ make up water	26
5 Gas connection	26
5.1 Gas connection	26
5.2 Gas pressures	26
5.3 Gas/air ratio regulation	26

6	Electrical connection	27
6.1	General	27
6.1.1	Mains voltage	27
6.1.2	Control connections	27
7	Controls	31
7.1	Control box	31
7.2	Boiler control	32
7.2.1	Introduction	32
7.2.2	Simple time clock and on/off room thermostat (control based on time and room temperature)	32
7.2.3	Modulating OpenTherm® room controller (control based on time and room temperature)	32
7.2.4	Outside-temperature sensor (control based on outside temperature and settings as in Fig. 20)	32
7.2.5	Frost protection	34
7.2.6	Boiler temperature control	34
7.2.7	Low water level protection	34
7.2.8	Maximum protection (over heat thermostat)	34
8	Commissioning	36
8.1	Putting into operation	36
8.2	Gas rate measuring	37
8.3	Handing over	38
9	Control	39
9.1	The instrument panel	39
9.1.1	General	39
9.1.2	Instrument panel structure	39
9.2	Meaning of the various modes	40
9.2.1	General	40
9.2.2	Temperature mode	40
9.2.3	Programming mode	40
9.2.4	Service mode	43
9.2.5	'Forced High' mode	43
9.2.6	'Forced Low' mode	44
9.3	Adjusting parameters for the installer	44
9.3.1	DHW three-way valve (J)	46
9.3.2	Pump speed - central heating operation (L)	46
9.4	Putting the boiler out of operation	46

10 Fault finding	47
10.1 Fault finding table	47
10.2 Fault codes	47
11 Service & maintenance	50
11.1 General.	50
11.2 Inspection	50
11.2.1 Checking the boiler combustion	50
11.2.2 CO ₂ /O ₂ adjustment	51
11.2.3 Cleaning the siphon	53
11.2.4 Checking the ignition electrode, cable and gasket	54
11.2.5 Checking and cleaning the inspection glass	55
11.2.6 Checking for leakage (water, gas and flue gas side)	56
11.2.7 Checking the expansion vessel	57
11.3 Maintenance	58
11.4 Part list Selecta system boiler	62
11.5 Part list Selecta combi boiler	66

For user instructions: See inside boiler control cover.

PREFACE

These technical instructions contain useful and important information for the correct installation, operation and maintenance of the Remeha Selecta combi and system boilers.

Read these instructions carefully before putting the boiler into operation, familiarise yourself with their control functions and operation, strictly observing the instructions given. Failure to do so may invalidate warranty or prevent the boiler from operating correctly.

Installation must be in accordance with current gas safety (installation and use) regulations, the building regulations and relevant codes of practice.

The installation, commissioning and servicing of the boiler must be carried out by a competent person who holds valid ACS certification and to be a member of CORGI.

All electrical work must be carried out by a competent person and to be installed in accordance with the current IEE regulations.

Note: On completion a copy of the commissioning certificate should be completed and left with the customer.

If you have any questions, require an engineer to call on site, or if you need more information about specific subjects relating to this boiler, or it's installation please do not hesitate to contact our technical help line 0118 978 3434.

The data published in these technical instructions is based on the latest information (at date of publication) and may be subject to revisions.

We reserve the right to continuous development in both design and manufacture, therefore any changes to the technology employed may not be retrospective nor may we be obliged to adjust earlier supplies accordingly.

2 APPLIANCE INTRODUCTION

The Remeha Selecta is a wall mounted, fully modulating, condensing boiler, which is available in two versions:

- Remeha Selecta combi - boiler for central heating and the production of instantaneous domestic hot water.
- Remeha Selecta system - boiler for central heating and hot water production via a calorifier.

The Remeha Selecta series incorporates a pre-mix burner, frost protection, self diagnostic servicing LED, and lap-top/PDA connection for setting and or interrogating the controller. The boiler can be installed with either a vertical or horizontal concentric (fan assisted) flue.

The boiler is designed for sealed systems only and is not intended for use with open vented systems.

The Remeha Selecta combi is equipped with a plate heat exchanger for a rapid hot water supply. The specially constructed cast aluminium heat exchanger is suitable for recovery of both tangible and latent heat from the flue gas. The Remeha Selecta combi can be used as a post-heater for solar heating panels. A continuously monitored fully pre-mixed burner ensures low NOx and CO emissions. The closed air box means it can be positioned in almost any space. The appliance is suitable for natural gas or LPG (only with optional kit, available from Broag).

2.1 Central Heating Control

The central heating output can be controlled by either a standard room thermostat or alternatively, for higher system efficiency, via the integrated OpenTherm interface. This option offers full-modulation (100 - 25% of operating load) by using a suitable universal controller such as the Honeywell Chronotherm Modulating programmable room controller available from Broag. 230 Volt switching controls can also be used in conjunction with the optional relay kit from Broag.

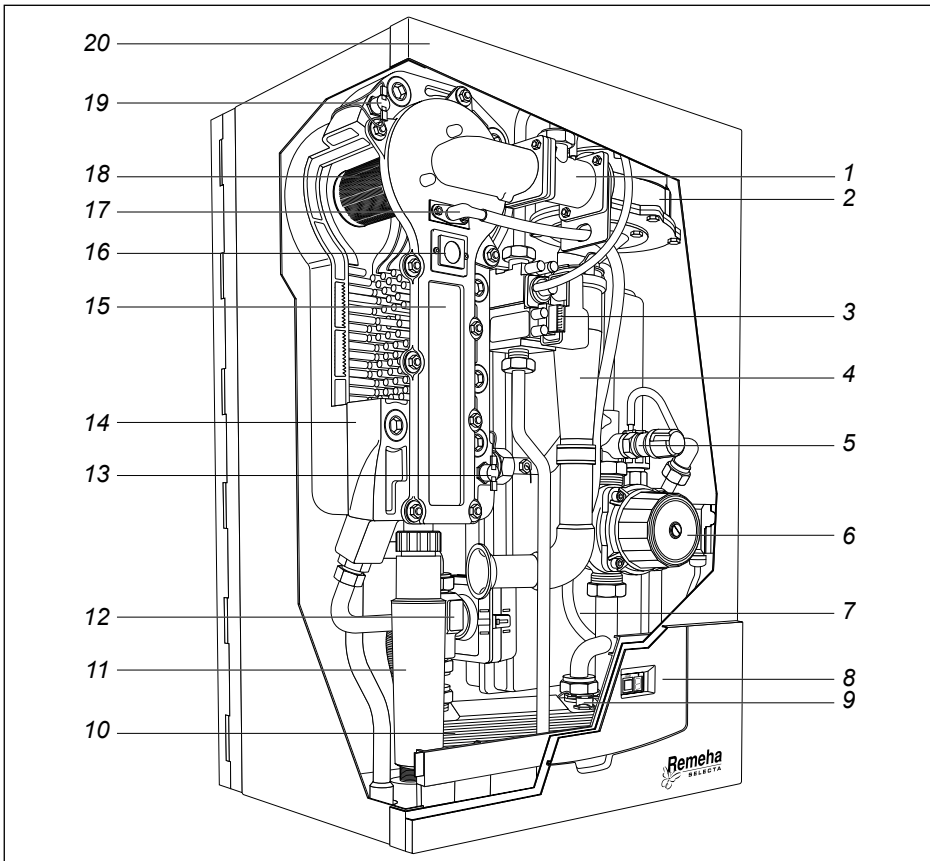

Fig. 02 Boiler layout Selecta (combi illustrated)

pdf

- | | |
|---|--|
| 1. Venturi | 11. Siphon / condensate outlet |
| 2. Fan | 12. 3-Way valve (combi boiler only) |
| 3. Gas combi block | 13. Temperature sensor return |
| 4. Air inlet tube | 14. Heat exchanger |
| 5. Safety valve | 15. Heat exchanger inspection cover |
| 6. Pump | 16. Inspection glass |
| 7. Expansion vessel | 17. Combined ignition/ ionisation probe |
| 8. Instrument panel | 18. Burner |
| 9. Flow temperature sensor (DHW; combi boiler only) | 19. Temperature sensor flow |
| 10. Plate heat exchanger (combi boiler only) | 20. Flue outlet / air inlet (60/100 mm; on top, not visible in this picture) |

2.2 Working principle

The Remeha Selecta's casing serves as a sealed air box, with air drawn in by the fan. On the outlet side of the fan is a venturi, into which a measured quantity of gas is injected based on the volume of air available. The fan speed control is dependent on the settings of the heat requirement and the prevailing temperatures (measured by the temperature sensors).

The method of gas/air combination ensures that the gas quantity is precisely adjusted to the air quantity. This creates optimum combustion over the whole heat input range. The gas/air mixture is mixed in the venturi and then flows to the burner. After combustion, the hot flue gas is directed through a specially designed, high efficiency cast aluminium heat exchanger with a large surface area, and transferring its heat to the heating water. The water vapour in the flue gas condenses against the "pins" within the heat exchanger, and the heat released during this process (the so-called latent or condensation heat) is also transferred to the heating water. The condensate water formed is discharged via a siphon on the bottom of the heat exchanger.

NOTE: In normal operation, the boiler's flue gas discharge will produce a visible white condensing "plume" and care should be taken when choosing a location.

2.3 Combi boiler operation

The Remeha Selecta combi contains a facility for providing domestic hot water in addition to central heating. The opening of a hot water tap is detected by a temperature sensor, which is located on the cold water inlet side of the heat exchanger. This sensor then activates the motorised three-way valve to provide domestic hot water. Once the demand for hot water stops the motorised valve automatically returns to the central heating position. This three-way valve is electrically controlled by the control box and only consumes power when it is changing to a different position.

2.4 Advanced boiler control ('abc'- control)

An intelligent advanced boiler control ('abc') continuously monitors the boiler conditions and ensures a very reliable supply of heat. This control system is adept at dealing with negative influences from the system such as flow reduction, airflow problems and alike. In the event of such influences, the boiler will not go into "lock-out" failure mode, but will in the first instance modulate back. If necessary, depending on the nature of the circumstances, it will temporarily switch off (shutdown or control stop), and then after a short while simply try again.

NOTE: Provided that the situation is not actually hazardous, the Remeha Selecta will always try to supply heat. The 'abc'- control prevents unnecessary additional call outs.

3 DIMENSIONS AND TECHNICAL DATA

3.1 Dimensions

All dimensions of relevance to the installation of the appliance are shown in *Fig. 03* and *Fig. 04*. For clearance details, see *Fig. 05*.

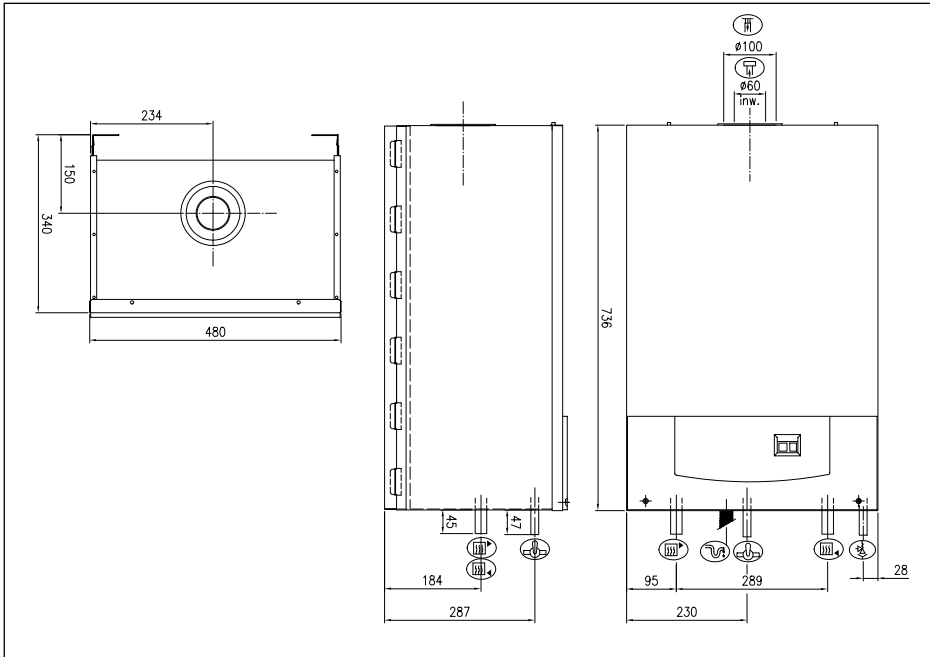









Fig. 03 Dimensions Selecta system

04.W5H.79.00002

-  Return connection 22 mm Ø o/d
-  Flow connection 22 mm Ø o/d
-  Gas connection 15 mm Ø o/d
-  Combustion air supply connection 100 mm Ø i/d
-  Flue gas discharge connection 60 mm Ø i/d
-  Condensate connection 25 mm Ø
-  Safety valve discharge 15 mm Ø

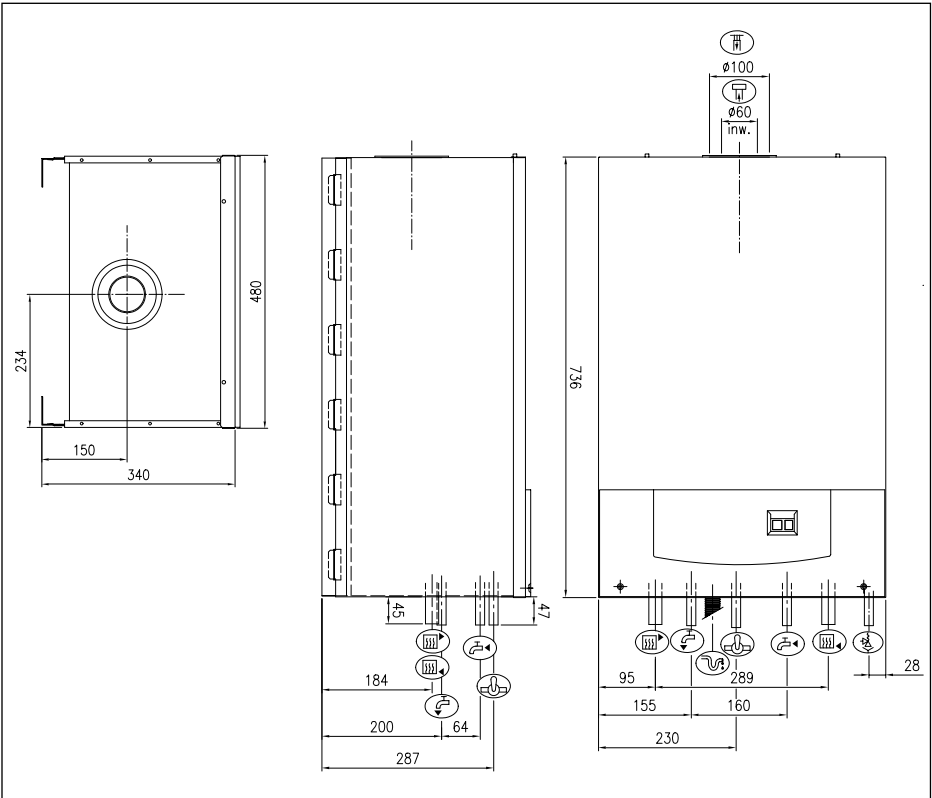











Fig. 04 *Dimensions Selecta combi*

04.W5H.79.00001

-  Return connection 22 mm Ø o/d
-  Flow connection 22 mm Ø o/d
-  Gas connection 15 mm Ø o/d
-  Combustion air supply connection 100 mm Ø i/d
-  Flue gas discharge connection 60 mm Ø i/d
-  DHW inlet connection 15 mm Ø o/d
-  DHW outlet connection 15 mm Ø o/d
-  Condensate connection 25 mm Ø
-  Safety valve discharge 15 mm Ø

3.2 Technical details

Boiler type	Selecta	combi	system
General			
Boiler control		Modulating	
Nominal output (80/70°C)	kW	5.1 - 16.0	5.1 - 16.0
Nominal output (50/30°C)	kW	5.6 - 16.8	5.6 - 16.8
Maximum output DHW	kW	23.89	-
Nominal input (CH) (GCV) Hs	kW	5.8 - 18.3	5.8 - 18.3
Nominal input (CH) (NCV) Hi	kW	5.2 - 16.5	5.2 - 16.5
Nominal input (DHW) (GCV) Hs	kW	5.8 - 26.7	5.8 - 26.7*
Nominal input (DHW) (NCV) Hi	kW	5.2 - 24.0	5.2 - 24.0*
Weight dry	kg	45	42
Maximum Noise level at 1 m distance from the boiler	dB(A)	<44	<44
SEDBUK rating		A	A
Gas- and flue details			
Category		II _{2H3P}	
Min/Max Inlet pressure natural gas	mbar	17 - 30	
Gas consumption (CH/DHW)	m _n ³ /h	0.6 - 1.7 / 2.5	
NO _x -emission (n = 1)	ppm	< 25	
Residual fan duty (full load)	Pa	95	
Mass flue rate (CH/DHW)	kg/h	26 / 39	
Classification due to discharging flue gases		C13, C33	
CH- side			
Water capacity heat exchanger + piping	l	2.6	
High limit temperature	°C	110	
Operating flow temperature	°C	20 - 90	
Operating range	bar	0.8 - 3.0	
DHW - side			
Maximum flow rate at 35°C Δt	l/min	10	-
Minimum flow	l/min	< 1	-
Water capacity	l	0.2	-
Inlet water pressure	bar	0.16 - 8.0	-

Electrical		
Main supply	V/Hz	230 / 50
Power consumption max.	W	130
Insulation class	IP	20
Fuse rating	A	3

Table 01 Technical details

* with Broag Kit No.1 and calorifier

3.3 General Specifications

(to be read with above table)

- One piece cast aluminium heat exchanger
- 22 mm Ø (m) flow and return connections
- 15 mm Ø (m) gas connection
- Maximum operating pressure of 3.0 bar
- Maximum operating temperature of 95°C
- Low NOx, < 25 ppm (O₂ = 0%)
- Pre-mix, fully modulating (25 -100%) gas burner with gas/air ratio control for maximum efficiency
- Intelligent advanced boiler control '**abc**' c/w a comprehensive operating, service and fault diagnostic facility
- Available for room sealed operation
- Supplied fully factory assembled
- Powder coated enamel steel casing and plastic front panel with cover
- Suitable for use with a Natural gas (standard) or propane (with optional kit)
- Efficiency of 98% at 80/60 °C (Hi)
- Max. efficiency of 109.2% (Hi) in fully condensing mode
- Manufactured to ISO 9001
- CE approved
- British Gas Approval Service listed
- Kiwa (Water regulations) approved product
- Flow temperature sensor DHW (for **combi boiler** only)
- 3-Way valve (for **combi boiler** only)
- Plate heat exchanger (for **combi boiler** only)

3.4 Optional Accessories

- Kit No. 1 = 3-Way DHW diverting valve c/w wiring loom, immersion sensor and ½ “ BSP pocket (for **system boiler** only)
- Kit No. 2 = volt free relay for use with external mains voltage switching time clocks (for **system and combi boilers**)
- Kit No. 3 = digital 7-day volt free switching time clock and harness for mounting in the boiler (for **combi boiler** only)
- OpenTherm® fully modulating room controller = for room compensation based on inside temperature (for **combi boiler** only)
- Outside sensor = for fully modulating weather compensation based on outside temperature (for **combi and system boilers** with Kit No.1 fitted)
- Propane kit = conversion from natural gas to propane (for **system and combi boilers**)
- Pipework cover plate = metal casing cover panel to hide bottom pipe connections (for **system and combi boilers**)
- Mounting frame = allows first fixing of pipework without mounting the boiler (for **system and combi boilers**)
- Cleaning tool = tool to clean the boiler heat exchanger (for **system and combi boilers**)
- McAlpine condensate connector = allows connection from flexible condense pipe to std overflow pipe (for **system and combi boilers**)

NOTE: Room controller and outside sensor cannot be used together.

4 INSTALLATION INSTRUCTIONS

The installation, commissioning and servicing of the boiler must be carried out by a competent person who holds valid ACS certification and to be a member of CORGI.

All electrical work must be carried out by a competent person and to be installed in accordance with the current IEE regulations.

4.1 General

Care should be taken when unpacking the boiler.

4.2 Boiler positioning

The boiler should be mounted in a room which, even during severe cold weather, remains frost-free (see *Par. 7.2.5 for more information*). The boiler should be mounted on a suitable vertical wall which is able to support the weight of the boiler.

If the boiler is to be installed in a timber framed building, please refer to British Gas publication: 'Guide for Gas Installations in Timber frame Housing', reference DM2.

4.3 Boiler mounting

The boiler can be mounted in two ways:

1. using the wall bracket supplied with the boiler,
2. using the mounting frame (optional) supplied in a separate box.

4.3.1 Clearance requirements

The gas and water connections are located on the bottom of the boiler. Whether the standard wall bracket or the mounting frame is used, there is adequate space to run the pipes behind the boiler if required. All components are accessible from the front of the boiler. However, we do recommend a minimum side clearance of 2.5 cm so that the unit is easy to open. A free space of 25 cm under the appliance and 40 cm above the appliance, see *Fig. 05*, should be regarded as the minimum requirement.

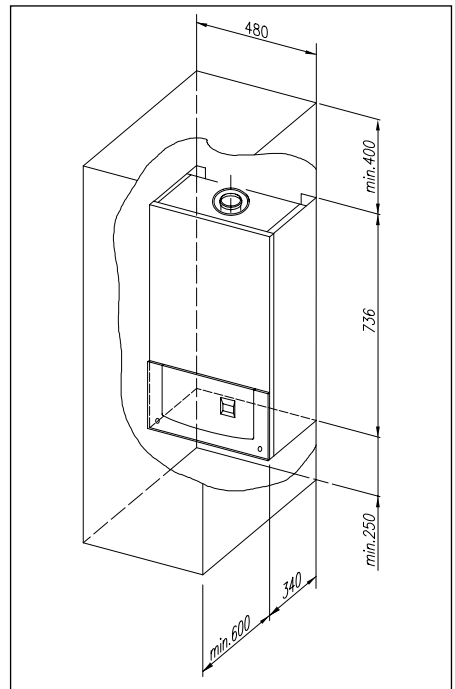

Fig. 05 Clearance requirements

04.W5H.79.00004

4.3.2 Mounting frame

Suitable for most applications as a two-stage installation. The frame, see *Fig. 06* and *Fig. 07* can be installed complete with all supply pipework to allow the system to be filled and tested. The boiler can then be fitted at a later date. Instructions for installing the mounting frame are supplied with it.

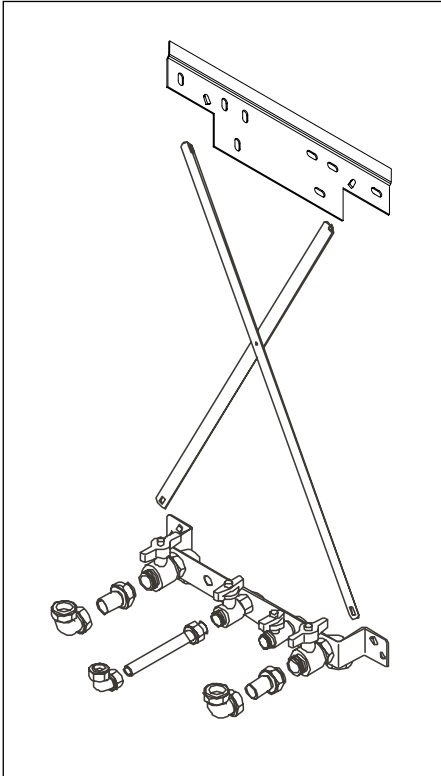

Fig. 06 Mounting frame system boiler
eps

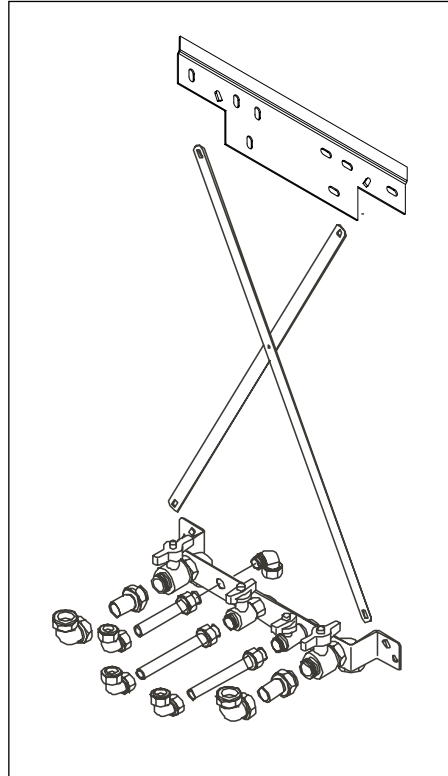

Fig. 07 Mounting frame combi boiler
eps

4.3.3 Wall bracket

Using the template provided mark fixing holes and flue outlet centre on the wall. Drill the wall, using the plugs and screws provided and secure the mounting bracket to the wall. Carefully lift boiler and locate the cut out in the back onto the wall bracket, see *Fig. 08*.

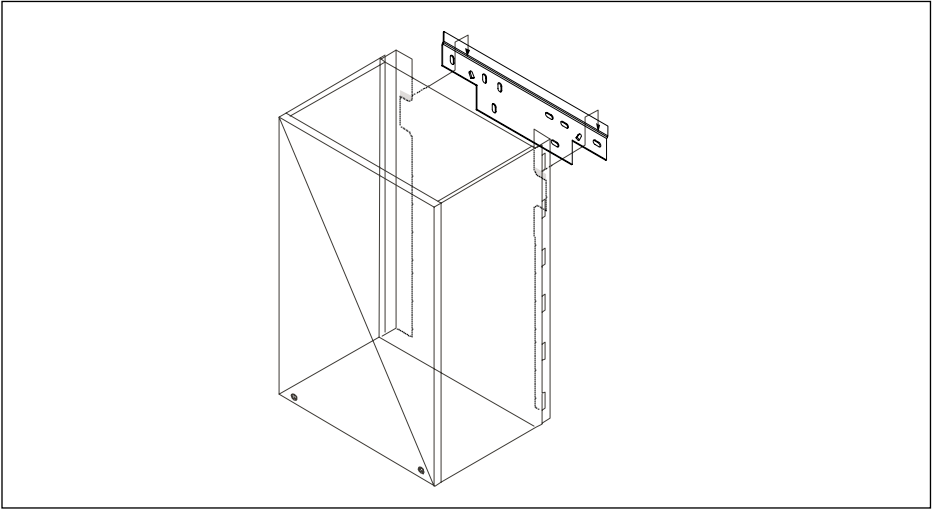

Fig. 08 Wall bracket

eps wall bracket

Note: It is possible to route pipework behind the boiler using this option.

Fixings supplied are suitable for brick/block wall only and alternative fixings should be used on different wall types.

4.4 Flue gas discharge and air supply

The Remeha Selecta is only suitable for room sealed operation with a concentric horizontal or vertical flue. After mounting boiler and before connecting the flue assembly, remove the dust cap from flue/air inlet connection.

Compartment ventilation is not required with this boiler with the concentric flue system.

Attention: plastic flues should not be used!

4.4.1 Flue terminal positions

The flue terminal positions for the Remeha Selecta are shown in *Fig. 09*. The minimum distances to the terminal can be found in *Table 02*.

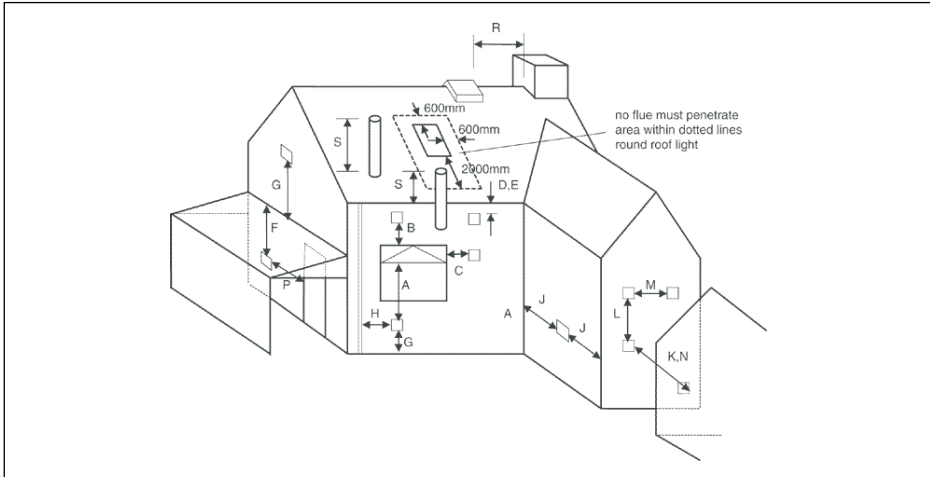

Fig. 09 Flue terminal positions

pdf

Dimensions	Terminal location	Minimum distance (in mm) to terminal (room sealed)
A	Directly below an opening, air brick, opening window, etc.	300
B	Above an opening, air brick, opening window, etc.	300
C	Horizontally to an opening, air brick, opening window, etc.	300
D	Below a gutter or sanitary pipe work	75 ¹⁾
E	Below the eaves	200
F	Below a balcony or carport roof	600
G	Above ground, roof or balcony level	300
H	From vertical drain/soil pipe work	75 ¹⁾
J	From an internal or external corner	30
K	From a surface or boundary facing the terminal	600 ²⁾
L	Vertically from a terminal on same wall	1500

M	Horizontally from a terminal on same wall	300
N	From a terminal facing the terminal	1200
P	From an opening in a carport (e.g. door, window) into the building	1200
R	From a vertical structure on the roof	n/app
S	Above an intersection with the roof	n/app

Table 02 Minimum distances to terminal

- 1) = Notwithstanding the dimensions above, a terminal serving a natural draught and fanned draught appliance more than 5kW heat input should be at least 300 mm and 150 mm respectively from combustible material.
- 2) = The distance from a fanned draught appliance terminal installed at right angles to a boundary may be reduced to 300 mm in accordance with Fig. 09.
n/app = not applicable.

4.5 Type of arrangement in connection with flue gas discharge

Arrangement according to CE: type C13, C33.

4.5.1 Single boiler, concentric room sealed flue

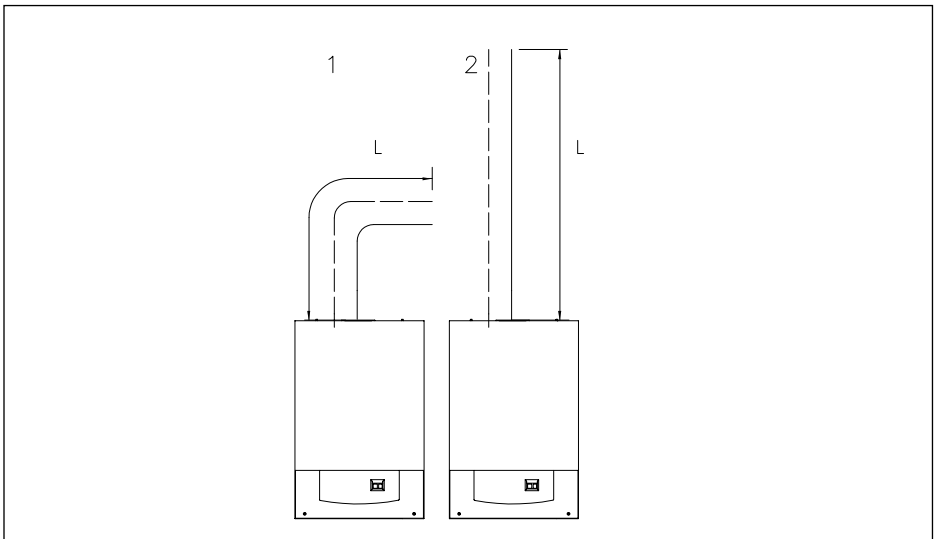

Fig. 10 Flue gas discharge duct, single boiler, room sealed application

04.W5H.79.00005

		Ø D (mm)
		Ø 60/100
Max. length horizontal including bend 'L'	m	7*
Max. length vertical with no bends 'L'	m	9*
Deduct per extra bend 90°	m	2
Deduct per extra bend 45°	m	1

Table 03 Permissible flue gas discharge lengths with closed systems

* **Note:** For lengths in excess of this, the 80/125 system can be used with a suitable adaptor. Please contact Broag for the required details.

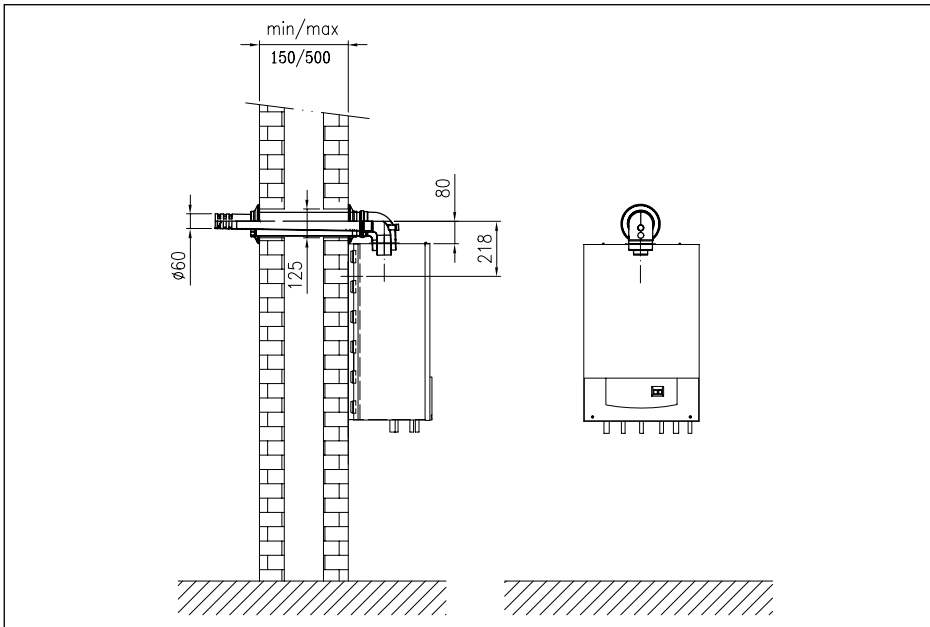

Fig. 11 Remeha Selecta with concentric horizontal flue

04.W5H.79.00011

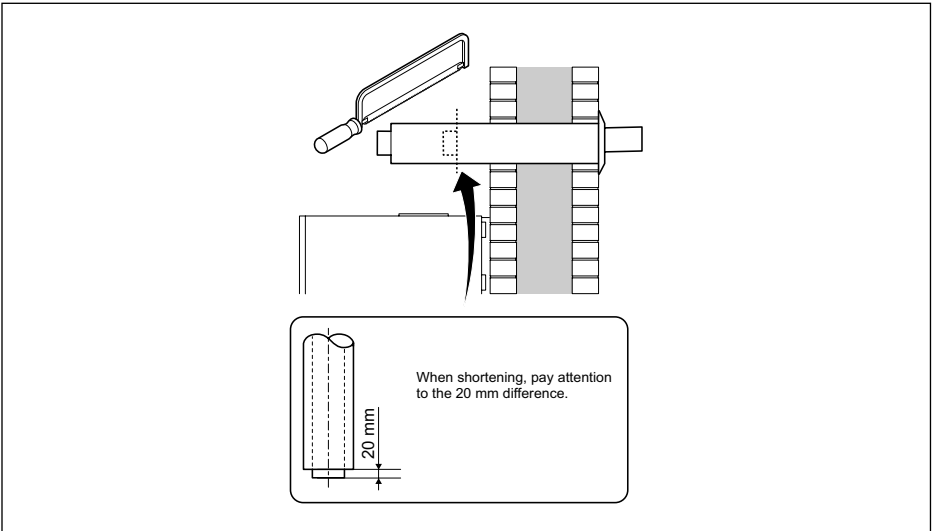

Fig. 12 Flue cutting instruction

pdf

* Detailed instructions for measuring and cutting flue are included with our horizontal flue kit.

4.6 Installation data

4.6.1 Condensate drain

The condensate drain from the boiler must be connected to a suitable wastewater drainage point, preferably within the building. The connecting pipe and fittings must be made of plastic material only. After assembly, fill the siphon with water. The slope of the drain pipe should be at least 30 mm/m. If pipe runs are made external to the building they should always be insulated.

4.6.2 Water treatment

Where system water treatment is required or specified (eg inhibitors), it must be compatible for use with an aluminium heat exchanger.

If water treatment is used we recommend only the following products which must be used in accordance with the manufacturers instructions:

'Copal'® manufactured by:
Fernox, Cookson Electronics
Forsyth Road
Sheerwater
Woking
Surrey GU21 5RZ
Tel No: 01483 793200
Fax No: 01483 793201
Email: sales@fernox.com
Web site: www.fernox.com

or: **Sentinal 'X100'**® manufactured by:
BetzDearborn Ltd
Sentinal
Foundry Lane
Widnes
Cheshire WA8 8UD
Tel No: 0151 424 5351
Fax No: 0151 420 5447

For the correct dosage and for further information on water treatment or system cleaning we advise direct contact with either of the above companies.

Note: Scale deposits in excess of 5 mm will reduce boiler efficiency and increase the risk of premature casting failure.

4.6.3 Safety valve discharge

A safety valve is fitted in the boiler and is set as standard to 3 bar.

If the pressure in the boiler becomes too high the pressure is relieved by releasing water outside via the safety valve discharge pipe. The safety valve discharge pipe must be at least 15 mm Ø. The discharge should be terminated facing downwards exterior to the building in a position where discharging water will not create danger or nuisance but remains in a visible position.

4.6.4 Expansion vessel

An 8 litre expansion vessel (with the vessel charge set to 0.5 bar) is fitted as standard within the boiler case and is suitable for use in a heating system with a water content up to 100 litres, operating at a flow temperature of 80°C, a maximum pressure of 3 bar and a maximum system static head of 5M above the boiler. If the system water content is greater than 100 litres, or the system static head above the boiler is greater than 5M, an additional vessel must be installed in the system to allow for the increase in expansion, see *Table 04*.

Boiler Safety Valve Setting (Bar)	3		
Vessel Charge (Bar)	0.5	1	1.5
Heating System Water Content (Litres)	Expansion Vessel Size (Litres)		
100	8		
125	10.4	13.6	19.5
150	12.5	16.4	23.4
175	14.6	19.1	27.3
200	16.7	21.8	31.2
225	18.7	24.5	35.1
250	20.8	27.3	39
275	22.9	30	42.9
300	25	32.7	46.8

Table 04 Expansion Vessel Size

4.6.5 Circulation pump

The Remeha Selecta is equipped with a Grundfos UPR 15-50 A0S1 circulation pump. This pump has a manual switch to select one of the three speed positions (see Fig. 13). If boiler parameter L/18 is set to 0 (see Table 09, service level), but will be overridden by the boiler control to III when in DHW mode and in the HTG mode if the boiler parameter L/18 is set to 1 (see Table 09, service level):

- highest setting during DHW operation
- during CH operation in its manual adjustable setting (to be set in the control unit by the installer, see Par. 9.2.3)
- if the middle position is required during CH operation, change the position switch on the pump and change parameter L/18 (see Table 09) to: **manual adjustable = 0**.

The residual head, is the head available for the installation, after deducting the boiler resistance, see Fig. 13.

Note: The standard pump overrun time is 3 minutes. If so desired, this can be adjusted to a different value (see Par. 9.2.3)

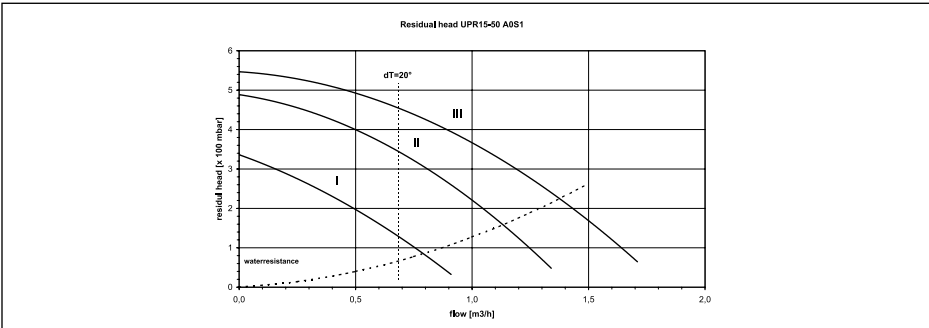

Fig. 13 Residual head Grundfos

4.6.6 Heating Water flow

The modulating controller of the appliance limits the maximum temperature difference between flow and return. As a result, the appliance should not be effected by low water flow. Therefore a system by-pass is not necessary, however building regulations should be complied with.

4.6.7 Water connections

The water connections are located on the bottom of the boiler (see Fig. 03 and Fig. 04). The CH connections are 22 mm Ø o/d. The DHW connection and cold water inlet are both 15 mm Ø o/d. When using the mounting frame connect to the isolation valves supplied. A 10 ltr. flow restrictor is supplied with the boiler and should be installed into a compression fitting directly onto the cold water inlet connection to the boiler.

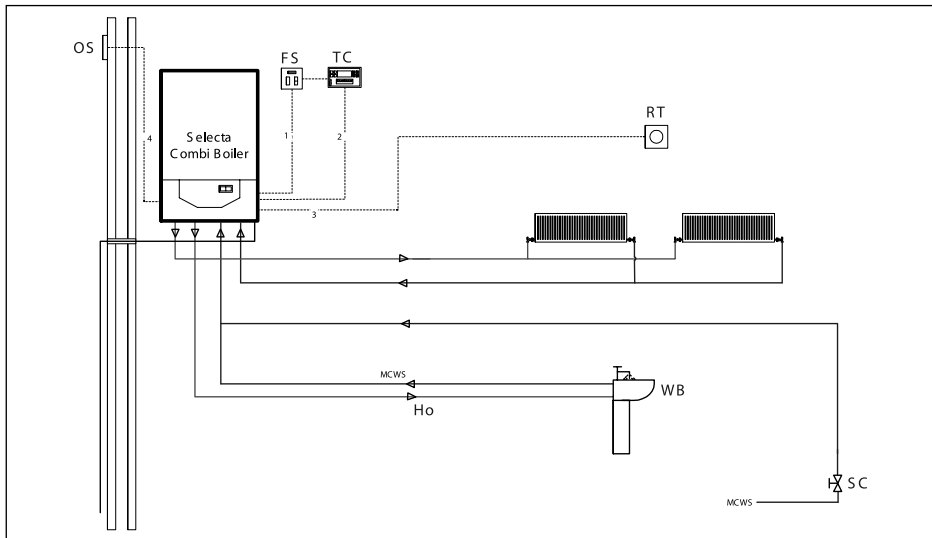

Fig. 14 Hydraulic example Selecta combi boiler (use in conjunction with electrical drawing Fig. 17)

pdf

Cable legend

- 1 = 3 amp fused supply (not supplied)
- 2 = external volt free switching time clock (not supplied)
- 3 = room thermostat (not supplied)
- 4 = outside sensor (not supplied)

Legend

- OS = outside sensor (optional)
- FS = 3 amp permanent fused supply (not supplied)
- TC = external time clock with volt free switching (not supplied)
- RT = room thermostat (not supplied)
- WB = wash hand basin
- SC = stop cock
- Ho = hot water outlet

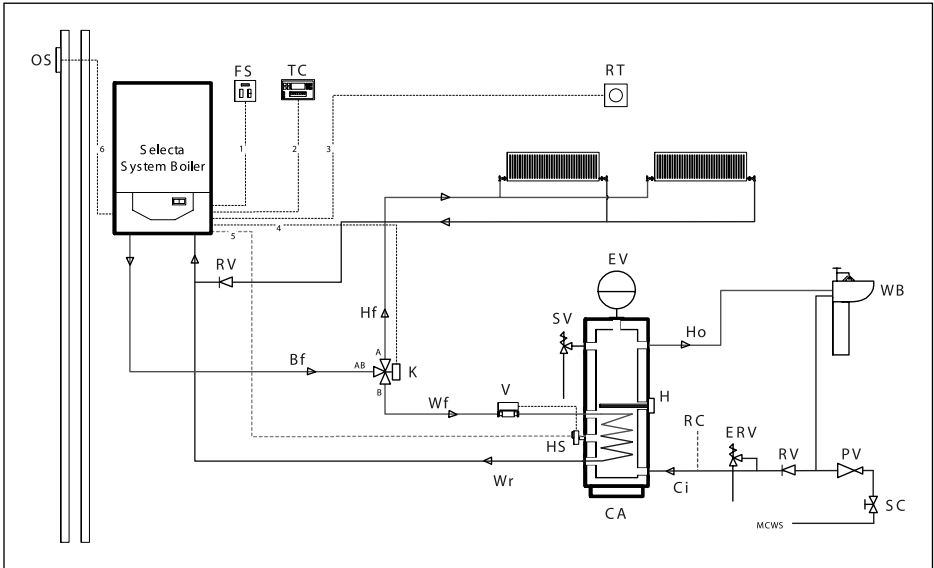

Fig. 15 *Hydraulic example Selecta system boiler (use in conjunction with electrical drawing Fig. 18)*

pdf

Cable legend

- 1 = 3 amp fused supply (not supplied)
- 2 = external volt free switching time clock (not supplied)
- 3 = room thermostat (not supplied)
- 4 = diverting valve cable (supplied with optional kit No. 1)
- 5 = HWS sensor cable (supplied with optional kit No. 1)
- 6 = outside sensor (optional)

Legend

- OS = outside sensor (optional)
- FS = 3 amp permanent fused supply (not supplied)
- TC = external time clock with volt free switching (not supplied)
- RT = room thermostat (not supplied)
- WB = wash hand basin

- SC = stop cock
- Ho = hot water outlet
- Ci = cold water inlet
- Hf = heating circuit flow
- Bf = boiler flow
- Wf = hot water primary flow
- Wr = hot water primary return
- K = kit No. 1 - 3 port diverting valve (optional)
- V = 2 port valve
- HS = sensor to be immersed inside thermostat pocket
- SV = temperature and pressure safety valve
- EV = expansion vessel
- H = immersion heater
- RC = optional secondary return connection
- ERV = expansion relief valve
- PV = pressure reducing valve
- RV = non return valve
- CA = stainless steel calorifier

4.6.8 Filling the system/ make up water

For initial filling and topping up, the system must be connected to the mains cold water using a standard mains fill kit (which complies with local water byelaws) and pressurised to 1 bar.

5 GAS CONNECTION**5.1 Gas connection**

The appliance is suitable for burning natural gas or LPG (with optional LPG set). The appliance must be connected in accordance with the current regulations. The gas connection is 15 mm Ø o/d. Supply pipeworks to be sized in accordance with relevant regulations to ensure that 2.5 CuM/hr of gas is available at the boiler.

We advise a gas filter be fitted in the gas supply line in order to prevent contamination of the gas valve.

5.2 Gas pressures

The gas valve is designed to accept an inlet pressure range of between 17 and 30 mbar. With the boiler running at full output there must be a minimum of 20 mbar (for NG) and 37 mbar (for LG) pressure available at the boiler to ensure correct operation. All combustion adjustments are made on the gas valve to CO₂ levels.

5.3 Gas/air ratio regulation

The Remeha Selecta is equipped with a factory pre-set gas/air ratio regulator (can be adjusted by an approved Engineer).

The purpose of this regulator is to keep the gas/air ratio in the burner as optimal as possible at all times within the modulating range.

This ensures clean and reliable combustion across the entire load range. In addition, it achieves high part-load efficiency.

6 ELECTRICAL CONNECTION

6.1 General

The Remeha Selecta is equipped with an electronic control and safety unit incorporating ionisation-flame protection. The heart of the boiler control is a microprocessor, the 'abc'-control, which both protects and controls the appliance.

6.1.1 Mains voltage

The connection to the electricity main has to be made in accordance with the appropriate regulations. The appliance is suitable for a 230V/50 Hz power supply, and is supplied with a flying lead. This appliance should be fused at 3 A.

Note: The boiler must have a permanent 230 volt power supply, which must not be used to operate the boiler

6.1.2 Control connections

All external control connections are made on the standard boiler connector (*X4*, see *Fig. 16*). To gain access to this connector, remove the front of the boiler casing (see *Par. 8.1, section 2*), lift and tilt the instrument panel down, making sure you engage the 3 hooks on its base on the bottom of the case. *Fig. 19* shows the location of the connector on the main pc board. The external connecting options are explained in the following paragraphs.

Warning: Under no circumstances should 230 volt connections be made directly on to connector *X4* as this will cause irreversible damage to the electronic board. If 230 volts controls are required a simple relay kit is available from Broag, see *Par.3.4*.

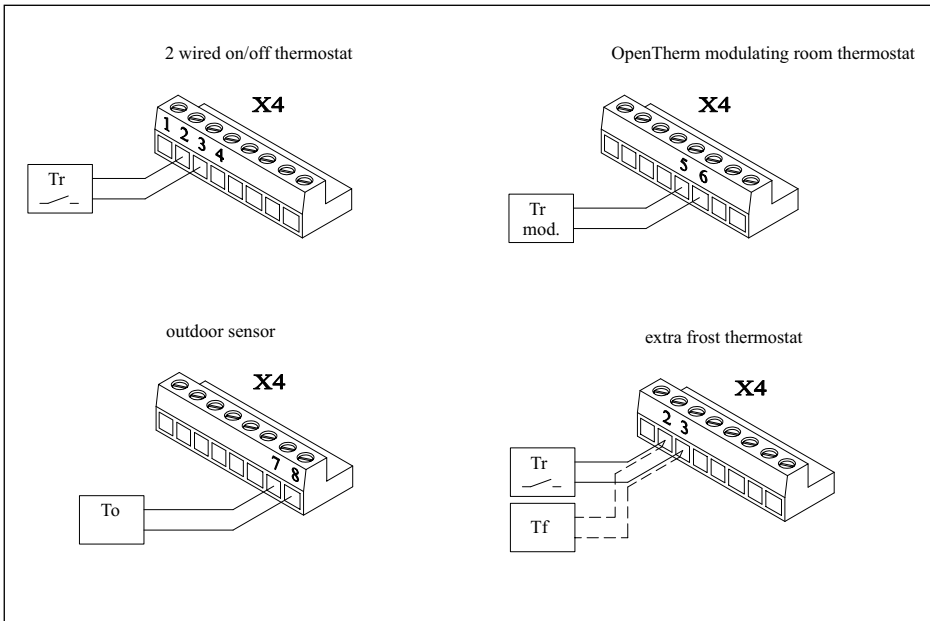

Fig. 16 External connections to terminal connector X4

pdf

Note: All electrical connections made to the X4 connector plug must be volt free

Explanation of diagrams:

1. Time only –on/off using a simple time clock or temperature only – on/off using a simple room stat.
2. Time and temperature – compensated using programmable modulating control.
3. Temperature only – weather compensated using an outside sensor.
4. Temperature and frost protection – on/off using a simple room and frost stat.
1. + 3. Time and temperature – simple time clock and weather compensated using an outside sensor.

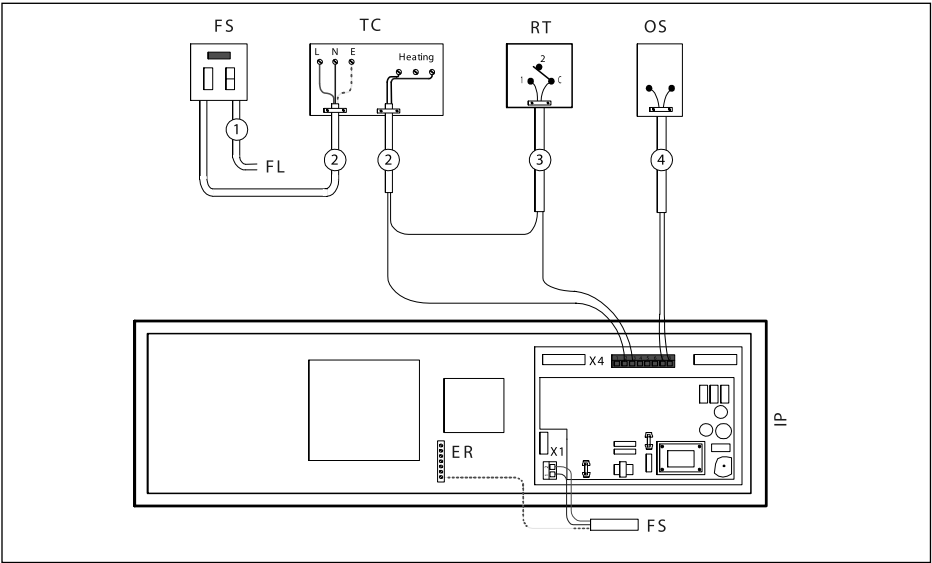

Fig. 17 Electrical drawing Selecta combi boiler (use in conjunction with hydraulical drawing Fig. 14)

pdf

Legend

- OS = outside sensor (optional)
- FS = 3 amp permanent fused supply via boiler 3 core cable fly lead (not supplied)
- FL = to boiler fly lead
- TC = external time clock with volt free switching (not supplied)
- RT = room thermostat (not supplied)
- ER = boiler earth terminal
- SC = stop cock
- IP = rear view of boiler instrument panel

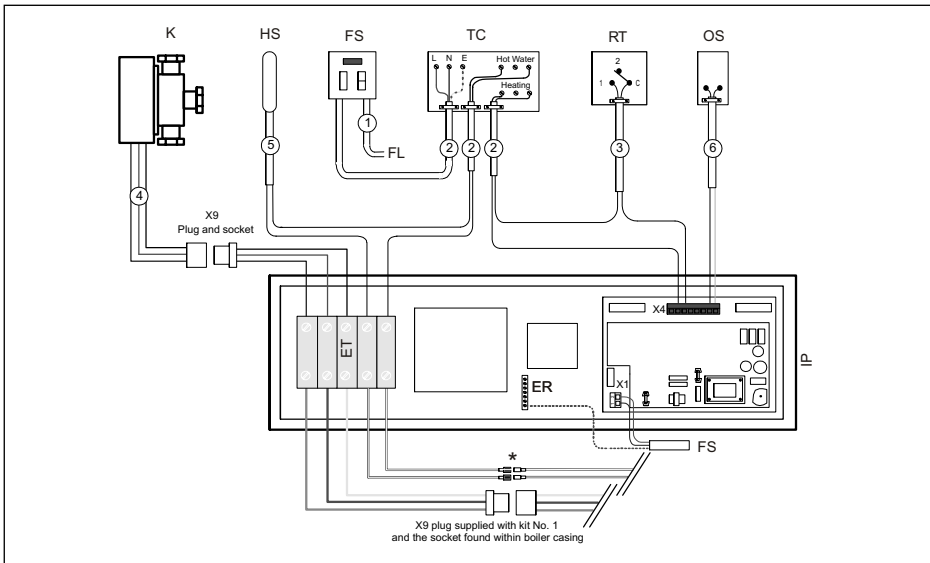

Fig. 18 Electrical drawing Selecta system boiler (use in conjunction with hydraulical drawing Fig. 15)

pdf

Legend

OS = outside sensor (optional)

FS = 3 amp permanent fused supply via boiler 3 core cable fly lead (not supplied)

HS = hot water sensor

FL = to boiler fly lead

TC = external time clock with volt free switching (not supplied)

RT = room thermostat (not supplied)

ER = boiler earth terminal

ET = kit No. 1 electrical terminals

IP = rear view of boiler instrument panel

** = connect to same coloured cables located within boiler casing*

Note: The heating and hot water switching must be volt free

7 CONTROLS

7.1 Control box

Fig. 19 shows the layout of the control box. This sketch shows where the connectors and fuses are positioned. Table 05 sums up the main characteristics of the control box.

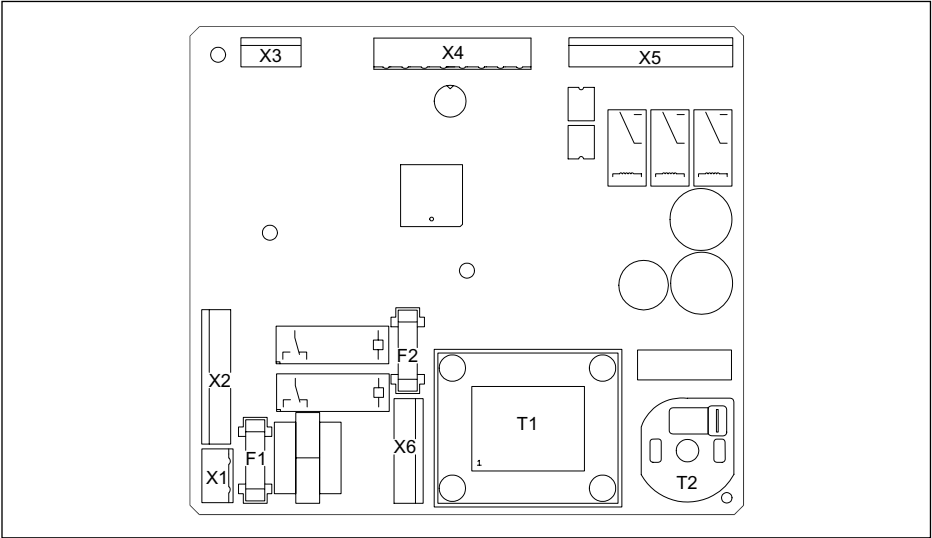

Fig. 19 Control box

04.W5H.79.00008

Make	GasModul Type MCBA 1459D
Mains voltage	230 VAC/50Hz
Pre-purge time	3 s
Post-purge time	3 minutes
Ignition time	2.4 s
Gas valve opening time	2.7 s
Anti-cycling time	150 s
Pump overrun C.H. position	Adjustable (see Par. 4.6.5)
Fuse value F1 (230V)	2 amp fast blow 20 mm glass fuse*
Fuse value F2 (24V)	4 amp slow blow 20 mm glass fuse*
DC-fan	24 VDC

Table 05 Characteristics control unit

* According to BS EN 60 127-2:1991

7.2 Boiler control

7.2.1 Introduction

The Remeha Selecta can be controlled in three ways:

1. Simple time clock and on / off room thermostat, whereby the boiler output varies between the minimum and the maximum to maintain the flow temperature set point on the boiler. If an outdoor sensor is also connected the flow temperature is determined by the outside temperature and the compensation graph *detailed in Fig. 20*.
2. Modulating OpenTherm® room controller, whereby the boiler output varies between the minimum and the maximum to maintain the temperature determined by the modulating controller.
3. Outside sensor and simple time clock, whereby the boiler output varies between the minimum and the maximum to maintain the flow in accordance with the compensation graph *shown in Fig. 20*.

7.2.2 Simple time clock and on/off room thermostat (control based on time and room temperature)

The Remeha Selecta is suitable for connecting a 2-wire 24V (or volt free) on/off room thermostat, which should be connected to terminals 2 and 3 on the terminal connector X4.

7.2.3 Modulating OpenTherm® room controller (control based on time and room temperature)

Using a modulating room controller takes full advantage of the modulating characteristics of the boiler. The modulating room controller communicates with the boiler and based on the room temperature, the modulating room controller constantly modifies the boiler flow temperature, based on system demand. This ensures that the boiler's output closely follows the property demand and prevents on/off cycling resulting in higher efficiencies.

The Remeha Selecta is prepared for communication via the "OpenTherm®" protocol. An suitable "OpenTherm®" modulating room controller is available from Broag.

The controller should be mounted in a suitable reference room. Connection is made with a twin cable (0.75 mm) to terminals 5 and 6 of the terminal connector, *see Fig. 16*.

Attention: For DHW production the boiler and controller must be set to the same temperature demand otherwise the controller setting will take priority.

7.2.4 Outside-temperature sensor (control based on outside temperature and settings as in Fig. 20)

When an outside-temperature sensor is connected to terminals 7 and 8 of connector X4 (*see Fig. 16*), the weather dependant heating control will be active if the following requirements have been met:

- There is no “OpenTherm®” thermostat connected (to terminals 5 and 6 of X4).
- There is heat demand from simple time clock or room thermostat (terminals 2 and 3 of connector X4).
- Parameter u (Base point according to Recom) is set between 1 - 60°C (factory setting = 20°C).

Note: The outdoor sensor (max. cable length 50 m) should be located on a north facing wall out of direct sunlight.

Parameter u (Base point) can be found in the user menu of Recom, see *Par. 9.3*. During a heat demand (HTG), the boiler control unit will follow a heat slope. The outside temperature (🌡️), the (HTG) Flow temperature setpoint (📊) and parameter 52 (Recom) are used as input parameters for calculating the angle of the heating slope.

Weather compensation slope setting:

- Outside temperature min. set point = 0°C (parameter 52, variable between 1 and -15°C)
- Outside temperature max. set point = 20°C
- Flow temperature set point at max. outside temperature = 20°C (parameter u, variable between 1 and 60°C)
- Flow temperature set point at min. outside temperature = 80°C (parameter 1, variable between 20 and 90°C)

This means that at 0°C outside temperature the boiler will go to a flow temperature of 80 °C, at 20 °C outside temperature the boiler will go to a flow temperature of 20 °C (parameter u), see *Fig. 20*.

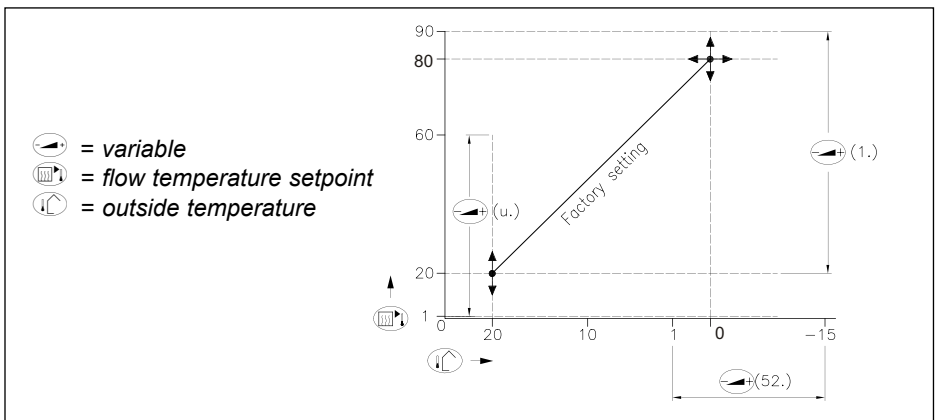

Fig. 20 Weather compensation slope

pdf

7.2.5 Frost protection

The boiler needs to be positioned in a frost-free room to prevent the condensate drain pipe freezing.

This boiler's frost protection automatically turns the boiler on if the temperature drops below a certain level. (explained in more detail below).

If the temperature of the water in the **boiler** drops too low, the built-in boiler protection becomes active. It works as follows; if the water temperature:

- is lower than 7°C, the circulation pump is activated
- is below 3°C, the boiler is activated
- higher than 10°C, the boiler is switched off and the circulation pump post-circulates for 15 min.

Attention: This is a protection facility for the boiler and pipework only and not for the installation.

In rooms subject to frost hazard (eg conservatories) it is advisable to install a frost thermostat and connect it in parallel with the room thermostat to terminals 2 and 3 of the terminal connector X 4, see *Fig. 16*. When the frost thermostat becomes active, the boiler goes into operation with the programmed maximum flow temperature as its limit.

7.2.6 Boiler temperature control

The Remeha Selecta is equipped with an electronic temperature control which operates on the basis of flow and return temperature sensors. The flow temperature is factory set to 80°C and should not be changed without reference to the system design Engineer, see *Par. 9.3* (works setting 80°C).

7.2.7 Low water level protection

The Remeha Selecta is equipped with low water level and flow protection based on temperature difference between flow and return.

By modulating back the moment the water flow threatens to become too low, the appliance remains in operation for as long as possible. In case of too low a flow the appliance goes into temporary shutdown mode rather than failure or "lock-out".

7.2.8 Maximum protection (over heat thermostat)

The over heat thermostat locks out the appliance in case of an excessive water temperature (110°C). After rectifying the cause of the failure, the appliance can be reset by using the 'reset' -key.

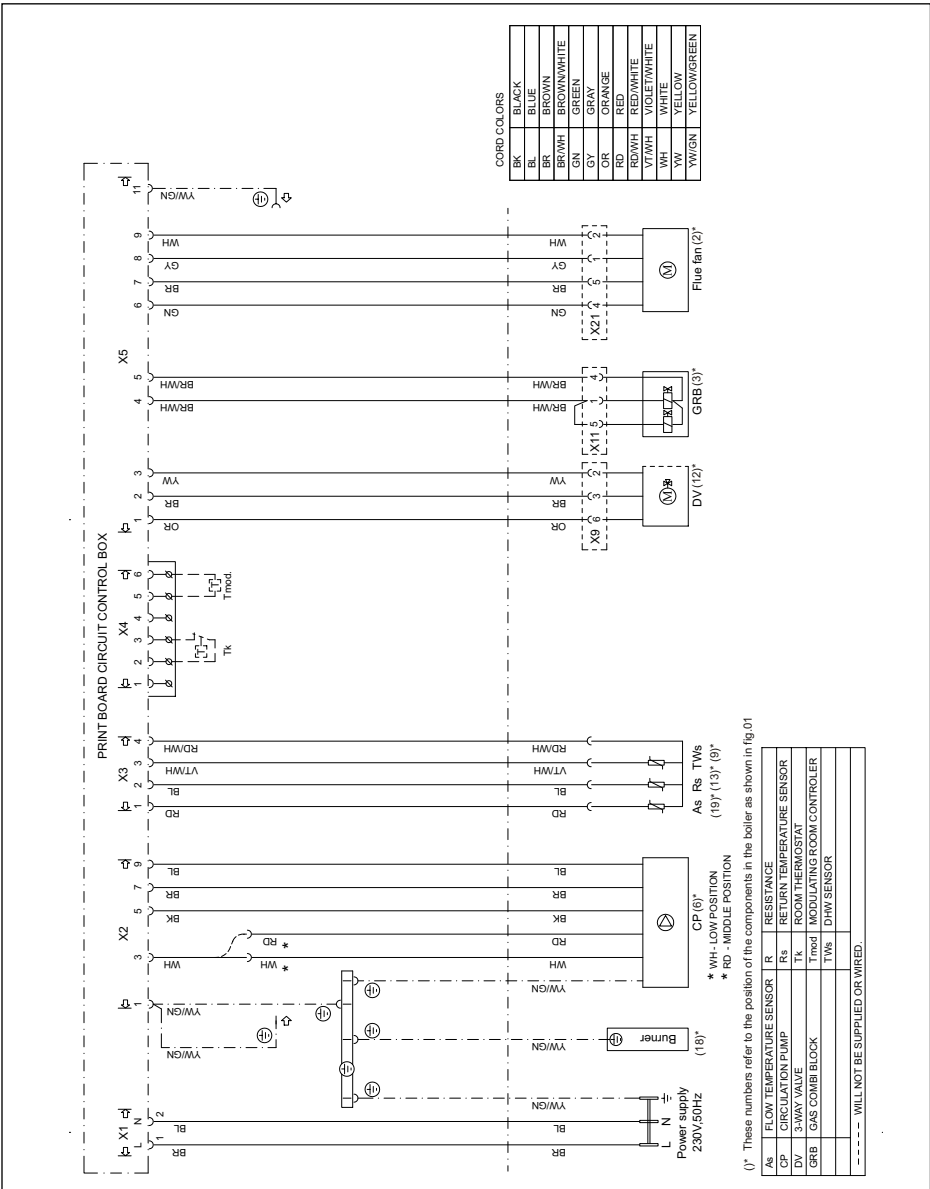

Fig. 21 Detailed internal wiring diagram

pdf

8 COMMISSIONING

8.1 Putting into operation

The system should be thoroughly flushed prior to connecting the boiler and in accordance with BS 7593 (1992).

Note: The boiler is suitable for both natural gas and propane. It is supplied as standard set for natural gas, therefore the following procedure must be carried out before the boiler is fired and commissioned on propane. Fit the propane restrictor (Broag option) and adjust the boiler parameters in accordance with the instructions supplied with the propane conversion kit (also use *Table 12* checking boiler combustion for propane)

Attention: if the boiler is to be used on LPG, an LPG conversion kit is required to be fitted before firing (Broag option)

1. Isolate the power supply to the boiler,
2. Remove the front panel (remove two screws at the bottom of the panel, pull the bottom of the panel forward and lift off the top),
3. Check the gas connection for soundness, purge and leave the isolation valve in the open position,
4. Check the electrical connections including earth,
5. Check the automatic vent is functioning and has vented the boiler,
6. Ensure that all boiler isolation valves are open,
7. Ensure that the boiler and system is full of water and pressurised to 1 bar,
8. Check the built-in circulation pump. Ensure that the impellor is free (remove the large headed screw in the pump head end and using a screwdriver spin the impellorshaft) this will vent the pump at the same time.

Attention: pump is mounted above the controls electrics- avoid getting water into the electronics during the venting process.

9. Vent the installation,
10. Remove the siphon assembly, fill with clean water and replace siphon,

Attention: this is vital as the boiler must not be operated with an empty siphon.

11. Check the flue connection,
12. Turn on the power supply to the boiler,
13. Set all controls to heat demand,
14. The boiler will now go into operation. The operational progress is shown via the 'code' window, see *Par. 9.2.4*,
15. The combi boiler will fire in the domestic hot water mode first to satisfy the plate heat exchanger temperature and then it will change over to heating.
If a system boiler is used in conjunction with our kit No1 then the boiler will operate in the domestic hot water priority mode and will have to satisfy this before changing over to heating. If other controls have been used then please refer to the manufactures user instructions.

16. Once the domestic hot water has been satisfied heat the installation to about 80°C. Turn off the boiler using the controls (not the power supply),
17. Once the pump has stopped vent the boiler / system again if necessary,
18. The boiler is now ready for normal operation,
19. Set the time clock, room thermostat, modulating control and the boiler controls to the values of your choice.
20. The system and combi boiler will operate in the heating mode only, unless there is a hot water demand (combi). Check hot water operation by turning on a hot tap, the boiler should fire and produce hot water or (system) create a demand on the cylinder (open a tap or raise the DHW set point).
21. Check combustion for correct operation - adjust if found necessary.
22. Re-fit front panel.
23. Complete boiler log book.

Notes:

- The Rehema Selecta is supplied with a number of factory settings. If other settings are required, see *Par 9.2.3*.
- If CO₂ and CO adjustments are required, see *Par. 11.2.1 and Par 11.2.2*.

8.2 Gas rate measuring

Both the system and combi boilers have pre-mixed combustion and therefore the combustion levels must be firstly set according to the *Table 12 in Par. 11.2.1* and only when these levels are within tolerances should the gas rates be checked.

Please be aware that when you use the forced high service mode that the boiler is designed to give the maximum heat input of 24 kW (NCV) and when you used the forced low mode service mode it will give 5.2 kW (NCV) on both the system and combi boilers.

Procedure:

1. Ensure all other gas appliances are turned off;
2. Operate the Selecta boiler in the '**Forced High**' service mode for at least 2 minutes prior to taking a meter reading;
3. Record the meter reading;
4. After 2 minutes of uninterrupted boiler operation on high fire take another meter reading and record;
5. Now operate the Selecta boiler in the '**Forced Low**' service mode and wait for at least 2 minutes prior to taking a meter reading;
6. Record the meter reading;
7. After 2 minutes of uninterrupted boiler operation on low fire take another meter reading and record;
8. Press the rest button on the boiler to remove the boiler from the '**service**' mode;
9. Calculate the gas consumption and refer to the figures in the technical details (see *Par. 3.1*).

Calculation;

$$\text{kW} = \frac{3600 \times \text{m}^3 \times 9.69}{\text{Time in seconds}} \quad (\text{NCV})$$

8.3 Handing over

The installer should instruct the householder fully in the operation of the boiler and any controls fitted and ensure all instructions are left with the house holder.

User Information

This boiler has inbuilt safety functions- Frost protection which automatically turns the boiler on if the temperature drops below a certain level. Therefore the boiler may come on during the night in extremely cold conditions.

Pressure relief valve, if the pressure in the boiler becomes too high the pressure is relieved by releasing water outside via a pipe. If you notice water coming from this pipe please contact your heating engineer immediately.

User Maintenance

To clean the boiler casing use a damp cloth only, do not use any abrasive cleaner.

WARNING: any servicing, maintenance or adjustments to this boiler must be carried out by a competent Engineer, with the relevant certification i.e.: CORGI, ACOPS, IEE regs. etc..

9 CONTROL

WARNING- Any servicing, maintenance or adjustments to this boiler must be carried out by a competent Engineer, with the relevant certification ie: CORGI, ACsS IEE regs. etc..

9.1 The instrument panel

9.1.1 General

The Remeha Selecta is equipped with an advanced appliance control consisting of, among others:

- Control unit with microprocessor,
- Communication facilities with various controllers,
- Simple instrument panel, including connection for PC/PDA.

The setting and read-out options on the instrument panel are divided into three levels:

- 1 User level (relatively accessible)
- 2 Installer level (accessible with PC/PDA or service tool only)
- 3 Works level (accessible via PC/PDA or service tool with works code only, exclusively for Broag personnel)

9.1.2 Instrument panel structure

The programming and reading of various control parameters is achieved using the user friendly control panel, equipped with a 'reset'- key, a display and a 'prog.'-key, see Fig. 22.

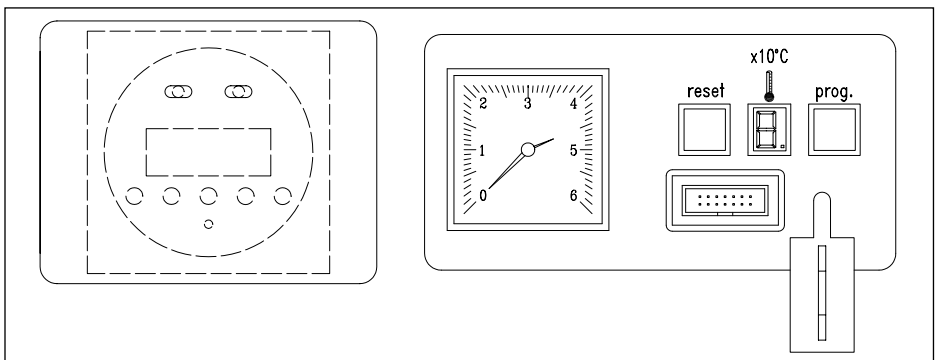

Fig. 22 Instrument panel (with optional clock = dotted line)

04.W5H.79.00007

9.2 Meaning of the various modes

9.2.1 General

After turning on the electric power to the boiler, or after pressing the 'reset'-key, the display defaults to the temperature mode. By pressing the 'prog.'-key it is possible to scroll through the display options, each key press moves to the next mode.

5 modes are available:

1. Temperature mode - Display shows number only no red dot (Default)
2. Programming mode - Display shows a number with a red dot illuminated
3. Service mode - Display shows a number with a red dot flashing
4. 'forced High' mode - Display shows \overline{H}
5. 'forced Low' mode - Display shows \overline{L}

Changes to the programming mode can be carried out via the boiler control panel, see *Par. 9.2.3*.

Changes to the settings at service level should only be carried out by a qualified Engineer using a PC or service tool, see *Par. 9.3*.

Note: The settings at works level are intended exclusively for Broag personnel and will therefore not be described.

9.2.2 Temperature mode

The temperature mode shows 1 digit per 10°C of boiler water temperature. For example, a $\overline{6}$ on the display indicates a temperature of 60°C ± 5°C. In temperature mode the red dot does not illuminate or flash.

9.2.3 Programming mode

The programming mode is separated in six groups (I till VI), with settings for pre-heat levels, DHW, CH and pump. In each group only one option can be active. A dot is flashing with the activated setting.

Note: Changes to the factory default settings effect the boiler operation and should only be carried out after reading and understanding the following instructions.

To activate an option within a group:

In the temperature mode briefly press the 'prog'-key once, the letter \overline{P} appears on the display. Press the 'prog'-key for more than 1 sec and the letter ' \overline{P} ' will flash twice confirming entry into the programming mode. Press the key again and \overline{I} will appear in the display with a static red dot, to activate this option press and hold the 'prog'-key. Each subsequent press of this key will display the numbers and letters of the relevant parameters displayed in sequence (options \overline{I} to \overline{F}), see *Table 06*.

The number will remain but the red dot will flash indicating that this option (“Pre-heat level 1: heat maintenance temp 0 °C”) within group I, is active and the other three options [2], [3] and [4] are inactive.

To change an option within a group:

To change the active option (if there are more than one in the group), select the new option required and activate as previously described, this will automatically de-activate the previous selected option.

The group VI, with only one option when ([F]) appears in the display the red dot is pre-set to flashing (high speed on CH operation) to select low speed option press and hold the ‘prog’-key for more than 1 sec the red dot will become static. The ‘prog’-key toggles between the two options. Returning to the main display will store the new selection automatically.

Notes:

- If no key is pressed for 60 secs whilst in programming mode, the display will automatically return to the ‘temp’- mode.
- If electrical failure should occur, the programme settings will be retained.

Group	Option	Description	Explanation
I Combi boiler only	[1]	Pre-heat level 1: heat maintenance temp. 0 °C	With each pre-heat level the hot water system is at least kept at the corresponding temperature. The higher the level, the sooner you have hot water. The lower the level, the more economical the appliance is.
	[2]	Pre-heat level 2: heat maintenance temp. 40 °C.	
	[3]	Pre-heat level 3: heat maintenance temp. 50 °C.	
	[4]*	Pre-heat level 4: heat maintenance temp. according to parameter r/4 Factory setting r/4 = 45°C	
II	[5]*	CH ‘ON’ and DHW ‘ON’	In a holiday period you can use the [6] setting to prevent the DHW system from being kept warm. With your room thermostat you can determine whether your house is kept warm.
	[6]	CH ‘ON’ and DHW ‘OFF’	

III	7	DHW temperature 45 °C	With this option you can set the maximum DHW temperature.
	8	DHW temperature 55 °C	
	9 *	DHW temperature according to parameter 3/3 Work setting 3/3 = 50 °C 1)	
IV	A	CH flow temperature 60 °C	In the less cold periods of the year the radiators need not be heated to the same extent. With these parameters you can lower the flow temperature. This is not necessary if you have a modulating controller or outside sensor connected.
	b	CH flow temperature 75 °C	
	C *	CH flow temperature according to parameter 1/1 Factory setting 1/1 = 80 °C	
V	d *	Pump overrun according to parameter 2/2 Factory setting 2/2 = 3 minutes	If there is danger of your heating system freezing, continuous water circulation is advisable. Setting 'E' recognises this.
	E	Pump continuous circulation	
VI	F *	Pump position during CH-operation. Parameter F selected (red dot is flashing) means: pump is circulating at high speed	With this parameter you can choose whether the pump circulates at high speed or at low (manual adjustable) speed during CH operation. To change this parameter, keep the ' prog '- key pressed in for more than 1 sec.

Table 06 Overview and meaning of parameters

* These values have factory default settings which can only be changed using a PC/PDA and the Recom software with the interface kit.

1) When a calorifier sensor or thermostat is installed, this temperature setting must be used.

9.2.4 Service mode

Service mode displays the boiler operation sequence and mode.

To enter the service mode:

In the temperature mode briefly press the ‘**prog**’ -key twice. Each subsequent press of this key will display the numbers and letters of the relevant operating codes displayed in sequence (0 – 9) with a flashing red dot.

A description of the meaning of each code is given in *Table 07*.

Step	Description
0	Idle, no heat demand
1	Pre-purge / post-purge
2	Ignition
3	CH - On
4	DHW - On
5	Waiting for fan to reach high speed
6	Flow temperature more than 5°C above set point
7	Pump over run CH-mode
8	Pump over run DHW mode
9	Burner off because one of the following has been exceeded: - Flow temperature set point - Flow temperature rise to fast - Difference between flow and return temperature exceeding 45°C
H	On ‘forced High’ mode*
L	On ‘forced Low’ mode*

Table 07 Description of Service mode read-out

* See Par. 9.2.5 and 9.2.6 for access.

Note: If no key is pressed for 1 min whilst in service mode, it automatically returns to temperature mode.

9.2.5 ‘Forced High’ mode

In ‘forced High’ mode the appliance will operate at its maximum output for 15 minutes (flow temperature dependant). This is the output setting for DHW operation. To enter this mode, press the ‘**prog**’-key briefly three times whilst in temperature mode. The letter **H** then appears on the display. By pressing the ‘**prog**’-key for more than 1 sec, the ‘forced High’ mode becomes active. The letter **H** flashes twice to confirm this. To terminate this mode prematurely press the ‘**prog**’-key again for more than 1 sec..

9.2.6 'Forced Low' mode

In 'forced Low' mode the appliance will burn at its minimum output for 15 minutes (flow temperature dependant). To enter this mode, press the '**prog**'-key briefly four times whilst in temperature mode. The letter **L** then appears on the display. By pressing the '**prog**'- key for more than 1 sec, the 'forced Low' mode becomes active. The letter **L** flashes twice to confirm this. To terminate this mode prematurely press the '**prog**'-key again for more than 1 sec..

9.3 Adjusting parameters for the installer

Warning: D.N.C. means DO NOT CHANGE the factory default setting.

Adjustment of the installer parameters cannot be made through the boiler keys. To change settings in the MCBA control unit, a PC/PDA and the Recom software with the interface kit must be used (Broag options). This should only be carried out by a product trained Engineer.

User parameters: (according to Recom)	Description	Adjustment range	Factory setting System boiler	Factory setting Combi boiler
1/1	Flow temperature set point	20 - 90 °C	80	80
2/2	Pump run on time HTG*	0 -10 minutes	3	3
3/3	DHW temperature set point	20 - 75 °C	50	50
r/4	Detection temperature DHW	25 - 65 °C	45	45
43/39	DHW Set temp / DHW on	0 - 50 °C, par. r / DHW On / Off	41: par. r / DHW on	41: par. r / DHW on
44/40	DHW temperature set point (3/3) / Detection temperature DHW (r/4)	DHW 45 - 55 °C, par. 3 / Flow 60 - 75 °C, par. 1	33: par. 3 / par. 1	33: par. 3 / par. 1
45/41	Continuous pump operation	Yes / No	No	No
50/42	D.N.C.	1 / 0	0	0
u/44	Compensation slope base point	1 - 60 °C	20	20

Table 08 User level

* Values below 1 minute cannot be displayed

Service parameters: (according to Recom)	Description	Adjustment range	Factory setting System boiler	Factory setting Combi boiler
4/5	Flow temperature set point during forced part load	20 - 90 °C	60	60
6/6-7	Fan speed at full load (HTG) D.N.C.	1000 - 6000 rpm	3900	3900
7/10-11	Fan speed at part load (HTG and DHW) D.N.C.	1000 - 6000 rpm	2300	2300
8/12	Modulation start point F/R, Δt °C D.N.C.	5 - 30 °C	25	25
b/13	Switch on differential (DHW) D.N.C.	1 - 20 °C	5	1
c/8-9	Fan speed at full load (DHW) D.N.C.	1000 - 6000 rpm	5450	5450
G/14	Forced part load time after start (HTG)	3 - 10 minutes	3	3
H/15	Fan speed at start D.N.C.	1000 - 6000 rpm	2500	2500
J/17	DHW control mode	0 / 1	0	0
L/18	Pump setting in heating mode	0 / 1 1 = high 0 = low (manual adjustable)	1	1
L/18	Pump setting during circulation	0 / 1	0	0
n/19	HTG cut in Dt (based on return) D.N.C.	0 - 20	3	3
o/20	Pre heat period	0 -10 hours	0	0
P/21	Boiler type	0: not used 1: Combi 2: System	2	1
U/38	Max. shut down time during continuous heat demand	0 -30: minutes	15	15
51/32	Hysteresis before ending DHW D.N.C.	1 - 30 °C	8	8
11/16	Differentiation end DHW-demand D.N.C.	-5 - 15 °C	0	0

I/45	Over temperature at DHW-production D.N.C.	0 - 30 °C	20	20
52/46	Minimal outside temperature for heatslope D.N.C.	-15 - 1 °C	0	0
53/47	Over-temperature primary circuit D.N.C.	0 - 60 °C	15	15

Table 09 Setting mode - service level

9.3.1 DHW three-way valve (L)

Factory set to L. AB port Common flow, port A to central heating and port B to DHW primary flow. If the valve has been installed the wrong way round it is possible by selecting parameter I to electronically reverse the operation of the three way valve. AB common flow port B to central heating and port A to DHW primary.

9.3.2 Pump speed - central heating operation (L)

Also software adjustable to high or low, factory setting: **high 1**.

If, in this position the system noises are too loud, you may adjust to a lower pump speed; change this parameter to: **low (manual adjustable) = 0**, see Par. 4.6.5

9.4 Putting the boiler out of operation

Temporarily out of operation with frost protection:

- Go - from temperature mode - into programming mode P.
- Go to parameter option S.
- Keep the programming key pressed in until the S is flashing. If you now set the room thermostat low, too, the appliance will be out of operation, while the frost protection remains active.
- *Do not* close the gas valve.
- *Do not* turn off the power supply.

Completely out of operation without frost protection:

- If the boiler is operating turn off the controls and allow to cool.
- Isolate the power supply to the boiler (the controller, if supplied, from the boiler will also be isolated).
- Close the gas valve.

10 FAULT FINDING

10.1 Fault finding table

Follow the procedure below in the given order:

1	No number appears on the boiler display	Check: - the supply voltage 230 V - the fuses in the control unit
2	If a failure code is shown on the boiler display	- Yes, go to <i>Par. 10.2</i> - No, go to 3
3	Check the operating mode of the boiler (<i>see Par. 9.2.4</i>)	- '0' (no heat demand): go to 4 - [i-G] , [H] or [L] : locate the fault with the aid of the given operating mode
4	Boiler will not start (without failure signal)	Check the room thermostat. It may be defective or not properly connected or set. The boiler also does not go into operation if the flow- or return temperature is too high, otherwise go to 7.
5	Boiler will operate for CH but not for DHW	Check temperature sensor on plate heat exchanger (combi boiler only).
6	Boiler will only operate for DHW but not for CH	Check temperature sensor on plate heat exchanger (combi boiler only).
7	Remove the front casing and check the operation of the boiler by connecting a bridging wire to the 6 way connector X4 (<i>see Fig. 16</i>) between terminals 2 and 3 (Tk).	Is the boiler going into operation? - Yes, check the controller settings. - No, verify whether the flow- or return temperature is too high. - Check the wiring and connections. - Check the control unit settings. If the boiler is still not working, check the control unit (you can do this by temporarily installing a replacement control unit).

Table 10 Fault finding table in case of modulating room thermostat and on/off room thermostat

10.2 Fault codes

In the event of a fault, two numbers will flash alternately in the window, and the latter number will be accompanied by an illuminated red dot. For an explanation of the various failure codes and their possible causes, please refer to the following failure table, *see Table 11*.

Important:

Before resetting the boiler, make a precise note of the failure code (numbers, including flashing/illuminating red dot) and always quote the relevant code when asking for support. The failure code is important for finding out the nature of the fault. The failure code can be read with the aid of the service tool.

	Description	Cause / checkpoints
00	Flame simulation (flame detected when control is in the off -position)	Gas valve is leaking or sticks in the open position. Check and replace valve.
01	Short circuit 24V	Check: the wiring.
02	<p>No flame formation or no ionisation (after 5 starting attempts)</p> <p>Note: Measure ionisation in Volts between terminal 5 on the terminal strip and earth (1V = 1 µA)</p>	<p>a. No ignition spark, check:</p> <ul style="list-style-type: none"> - the connection of ignition cable and spark plug cover - the ignition cable and the electrode for 'burn out' - the electrode distance; this has to be 3 to 4 mm - the earth connection <p>b. Ignition spark present, but no flame, check whether:</p> <ul style="list-style-type: none"> - the gas valve is open - the gas supply pressure is sufficient - the gas pipe has been purged - the gas valve is being actuated during ignition and opens - the electrode has been mounted correctly, and is clean - there is a blockage / assembly error in the gas pipe - the gas / air ratio has been adjusted correctly (see <i>Par. 11.2.1</i>) - re-circulation of flue gas is occurring (internally/ externally) - there is a blockage in the air supply or flue gas discharge (eg blocked siphon) <p>c. flame present, but no or insufficient (< 4 µA) ionisation, check:</p> <ul style="list-style-type: none"> - the earth connection of the ignition electrode - the flame should be stable - gas/air setup in full load and part load - the ignition electrode visually for white oxide (clean with sand paper or screwdriver) and electrode pins shape (do they have their original shape?) and distance between the pins (the gap should be between 3 and 4 mm) - whether one of the temperature sensors is defective (leakage current)
04		Power failure during failure shutdown.
05	External influences	Check for external EMC influences

11	Failure internal communication bus	Check: - cable connections on MCBA board - if there is moisture on the display - for external EMC influences
18	Flow temperature too high	Check: - pump operation
19	Return temperature too high	- the water flow, <i>see Par. 4.6.6</i> - whether the installation has been properly vented - the flow and return sensors for defects - the water pressure (min 0.8 bar)
24	Return temperature higher than flow	Check: - flow and return temperature sensor wiring - flow and return connections - direction of flow - pump is the right way round - flow and return crossed
31	Flow temperature sensor error	Flow temperature sensor short-circuited.
32	Return temperature sensor error	Return temperature sensor short-circuited.
36	Flow temperature sensor error	Flow temperature sensor not connected or defective.
37	Return temperature sensor error	Return temperature sensor not connected or defective.
77	Ionisation signal loss during operation (after 4 restarts during 1 heat demand)	Check: - re-circulation of flue gas (internal leakage or outlet construction/position incorrect). - insufficient air transport due to blockage. - adjustment of the boiler is incorrect. - low fire percentage set point and increase.
43	Parameters out of range	Check: the parameters in the memory.
Other codes	Control unit failure	After recording the 'flashing' fault code numbers: - First press reset - If the fault returns, record the code again, check the wiring for possible short-circuit or wrong connections - If the fault continues to occur, exchange the control unit

Table 11 Failure codes

11 SERVICE & MAINTENANCE

11.1 General.

The Remeha Selecta has been designed to need minimum maintenance, but to ensure optimum efficiency we advise that once a year the boiler should be checked and if necessary cleaned and reset.

All service and maintenance must be carried out by a qualified Engineer with the relevant training and certification (ie CORGI - ACS -IEE registrations etc.).

11.2 Inspection

The annual inspection of the Remeha Selecta can be limited to:

- Checking the boiler combustion

Note: Check the boiler for correct gas/air setup in full load by measuring the O₂ levels in the flue gas (direct measurement

- of CO₂ can lead to inaccuracies due to varying levels of CO₂ in the natural gas)
- Check/clean the condensate siphon (refill with clean water).
- Checking/clean the ignition electrode; gap adjustment (3 - 4 mm) replacing the gasket if necessary
- Check ignition probe earthing.
- Check the ionisation current with a DC voltmeter between terminal 4 on the green X4 plug and a suitable earth connection.

Note: The maximum ionisation current is 9µA and any reading lower than 4µA will indicate that the electrode will require replacement

- Check for leaks (water side and gas soundness).
- Checking the water pressure
- Check flue and air inlet system is clear and gas/water tight.
- Check safety controls
- Check control settings.
- Check boiler parameters
- Is flame shape stable and colour as described in *Par. 11.2.2*
- Check temperature sensors for resistance values against *Fig. 30* (humidity on sensors).

11.2.1 Checking the boiler combustion

This can be done by measuring the CO₂/O₂ percentage via the flue gas measuring point in the flue of the boiler.

To do this, fire up the boiler to a water temperature of approximately 70°C. If this check shows that the combustion of the boiler is outside of the tolerances indicated in *Table 12*, clean it according to the instructions in *Par 11.3*. If, after cleaning, the combustion of the boiler is still outside of the tolerances, then adjust CO₂/O₂ percentage according to the instructions in *Par. 11.2.2*.

Note: When checking combustion the CO₂ levels should be in accordance with *the Table 12 (+/- 0.3%)*. If the levels are outside these tolerances clean heat exchanger in accordance with the instructions in *Par 11.3*. If, after cleaning, the combustion figures are still outside these tolerances, then adjustments must be made to achieve the levels in accordance with the tolerance *in Table 13 (+/- 0.1%)*

	Fan Speed approx.	Natural gas		Propane	
		CO ₂	O ₂	CO ₂	O ₂
	rpm	%	%	%	%
Front panel not mounted					
Part load	2300	9.3 (+/- 0.3)	4.3 (+/- 0.4)	10.5 (+/- 0.3)	5.1 (+/- 0.4)
Full load	5450	9.3 (+/- 0.3)	4.3 (+/- 0.4)	10.5 (+/- 0.3)	5.1 (+/- 0.4)
Front panel mounted					
Part load	2300	9.5 (+/- 0.3)	3.9 (+/- 0.4)	10.7(+/- 0.3)	4.8 (+/- 0.4)
Full load	5450	9.5 (+/- 0.3)	3.9 (+/- 0.4)	10.7(+/- 0.3)	4.8 (+/- 0.4)

Table 12 CO₂ and O₂ percentage (checking values)

	Fan Speed approx.	Natural gas		Propane	
		CO ₂	O ₂	CO ₂	O ₂
	rpm	%	%	%	%
Front panel not mounted					
Part load	2300	9.3 (+/- 0.1)	4.3 (+/- 0.2)	10.5 (+/- 0.1)	5.1 (+/- 0.1)
Full load	5450	9.3 (+/- 0.1)	4.3 (+/- 0.2)	10.5 (+/- 0.1)	5.1 (+/- 0.1)
Front panel mounted					
Part load	2300	9.5 (+/- 0.1)	3.9 (+/- 0.2)	10.7(+/- 0.1)	4.8 (+/- 0.1)
Full load	5450	9.5 (+/- 0.1)	3.9 (+/- 0.2)	10.7(+/- 0.1)	4.8 (+/- 0.1)

Table 13 CO₂ and O₂ percentage (setting values)

Attention: Make sure the opening around the probe is properly sealed off when measuring!

The CO/CO₂ ratio should not exceed 0.02% at any time.

Maximum CO levels permitted = 100 ppm.

11.2.2 CO₂/O₂ adjustment

The CO₂ and O₂ levels can be adjusted by following the procedure below. Any adjustment required can be done via the setting screws on the gas block, see *Fig. 23*.

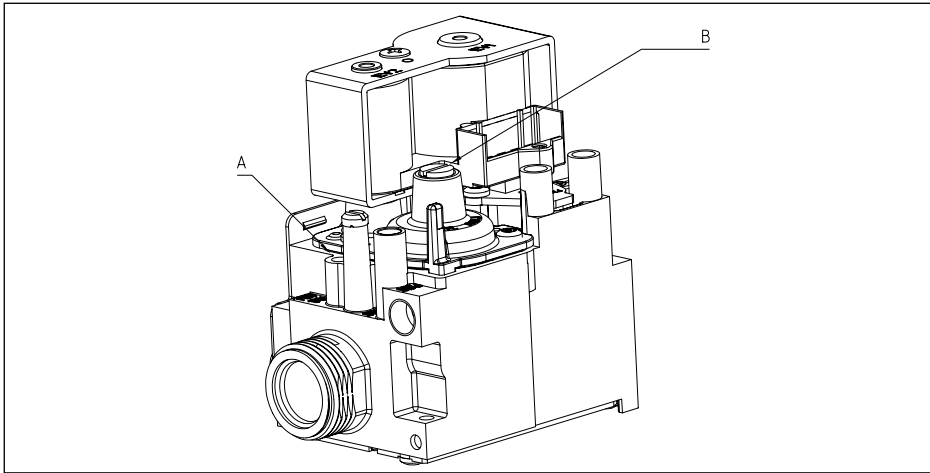

Fig. 23 Setting screws

00.W5H.79.00005

Procedure:

- Remove the boiler front panel (see Par. 8.1).
- Set the boiler to 'Forced High' mode, (see Par. 9.2.5).
- Remove the measuring point sealing cap (in the boiler flue) and insert the combustion equipment probe.
- After reaching the full load speed, allow the boiler temperature to rise and settle to about 70°C, measure the O₂/CO₂ percentage and compare it with the value in the table. Correct, if necessary, the gas/air ratio with the aid of set screw **A** on the gas block (see Fig. 23).
- Check the flame via the inspection glass, the flame must be stable with no lifting off and the burner surface shows glowing (orange) dots.
- Set the boiler to 'Forced Low' mode, (see Par. 9.2.6).
- After reaching the part load speed, allow the boiler temperature to settle, measure the O₂/CO₂ percentage and compare it with the value in the table.
- Correct, if necessary, the gas/air ratio with the aid of set screw **B** on the gas block (see Fig. 23).
- Check the flame via the inspection glass, the flame must be stable with no lifting off and the burner surface showing an even, orange glow.
- After adjusting the part load settings, a check must be carried out on full load setting as this can be effected by the part load adjustment. If necessary, correct the full load setting.

Note: The full load adjustment changes the gas/air graph slope angle, whilst the part load adjustment shifts the base point on a parallel axis; each adjustment therefore alters the previous setting slightly. Repeat this procedure as often as needed until the desired result has been achieved at both part and full loads.

- Remove the combustion equipment probe and replace measuring point sealing cap.
- Refit the front panel and return the boiler to 'temperature mode' by pressing the **'prog.'** -key and holding for more than 1 second.
- The boiler is now ready for normal operation.

11.2.3 Cleaning the siphon

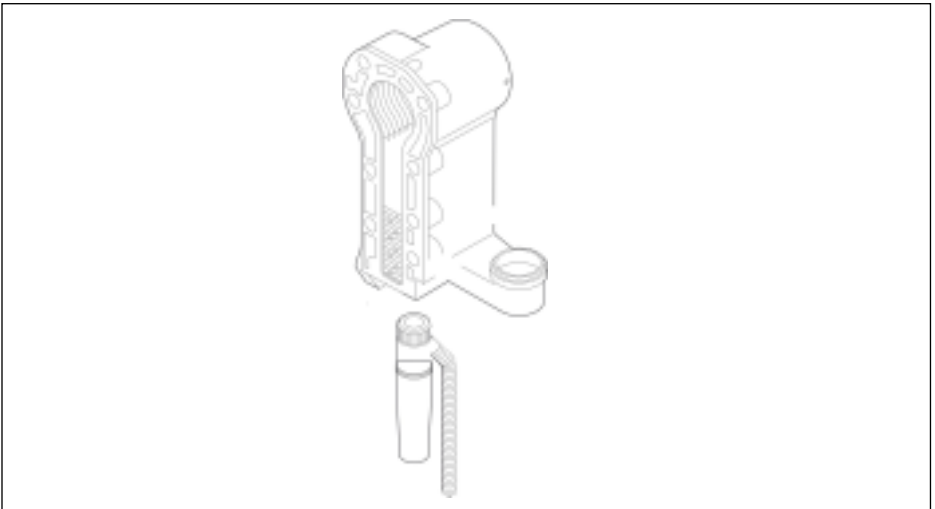

Fig. 24 Siphon cleaning

pdf

- Isolate the electrical supply to the boiler.
- Remove the boiler front casing cover.
- Lift and drop down the boiler instrument panel to completely reveal the siphon.
- Pull off the plastic flexible hose from the siphon.
- Loosen the sealing nut from top of the siphon.
- Release the complete siphon from the heat exchanger and remove from the boiler.
- Unscrew the siphon bowl and clean removing all debris
- Refill the siphon with fresh clean water and remount on the boiler.
- Re-assemble boiler replacing any damaged gaskets.

11.2.4 Checking the ignition electrode, cable and gasket

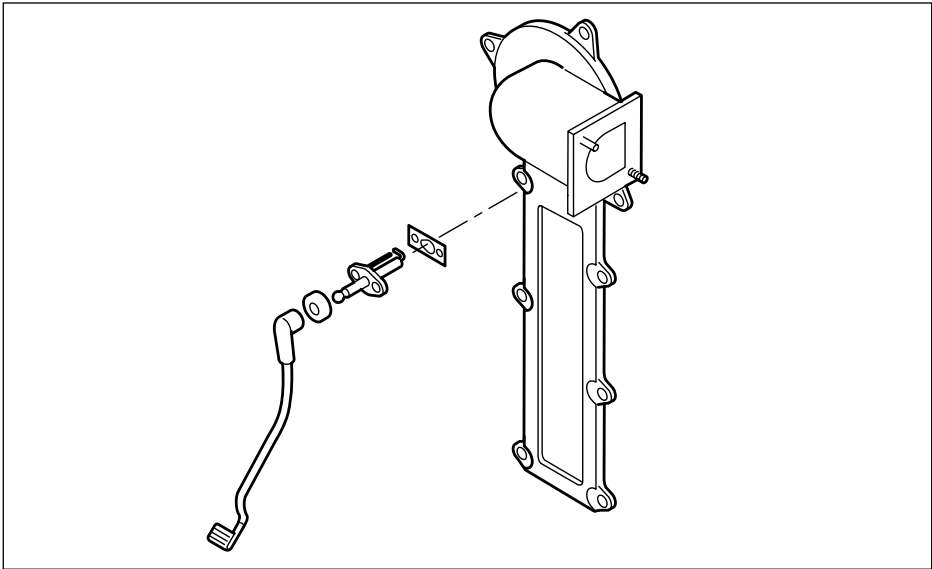

Fig. 25 Electrode checking

pdf

- Isolate the electrical supply to the boiler.
- Remove the boiler front casing cover.
- Pull off the spark plug cap from the electrode.
- Remove the two screws which secure the electrode, examine the earth lead which is held by one of the screws.
- Remove the electrode and examine the porcelain for cracks and clean the spark gap area with fine emery cloth to remove any unwanted debris.
- Check and replace the electrode gasket if it was damaged during removal.
- Check and adjust the spark gap to maintain a 3 to 4 mm dimension.
- Re-fit the electrode assembly and plug cap.
- Check the ionisation current with a DC voltmeter between terminal 4 on the green X4 plug and a suitable earth connection.
- The maximum ionisation current is 9 μ A and any reading lower than 4 μ A will indicate that the electrode will require replacement.
- Re-fit front casing cover replacing the gasket if it was damaged during removal.

Note: It is advisable to replace the electrode at least every two years to ensure reliable operation.

11.2.5 Checking and cleaning the inspection glass

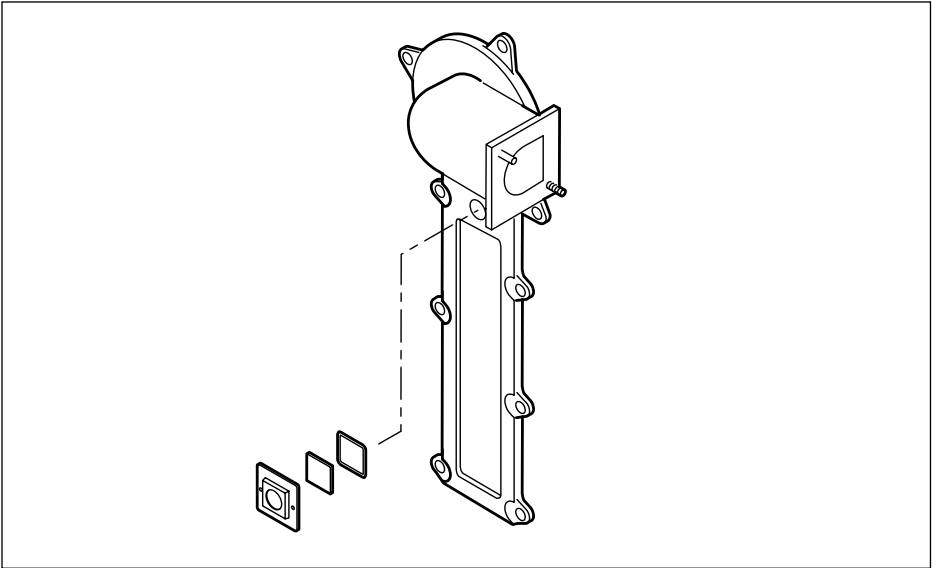

Fig. 26 Checking and cleaning the inspection glass

pdf

- Isolate the electrical supply to the boiler.
- Remove the boiler front casing cover.
- Remove the two screws holding the inspection glass plate.
- Replace inspection glass assembly, replacing the gasket if it was damaged during removal.
- Re-fit front casing cover replacing the gasket if it was damaged during removal.

11.2.6 Checking for leakage (water, gas and flue gas side)

Fig. 27 *Checking pipework connections*

pdf

- Isolate the electrical supply to the boiler.
- Remove the boiler front casing cover.
- Drop down the boiler instrument panel to completely reveal all the pipework connections.
- Visually examine the flue/water and combustion joints and repair as necessary.
- Examine all electrical connections and tighten or replace if necessary.
- Re-fit front casing cover replacing the gasket if it was damaged during removal.

11.2.7 Checking the expansion vessel

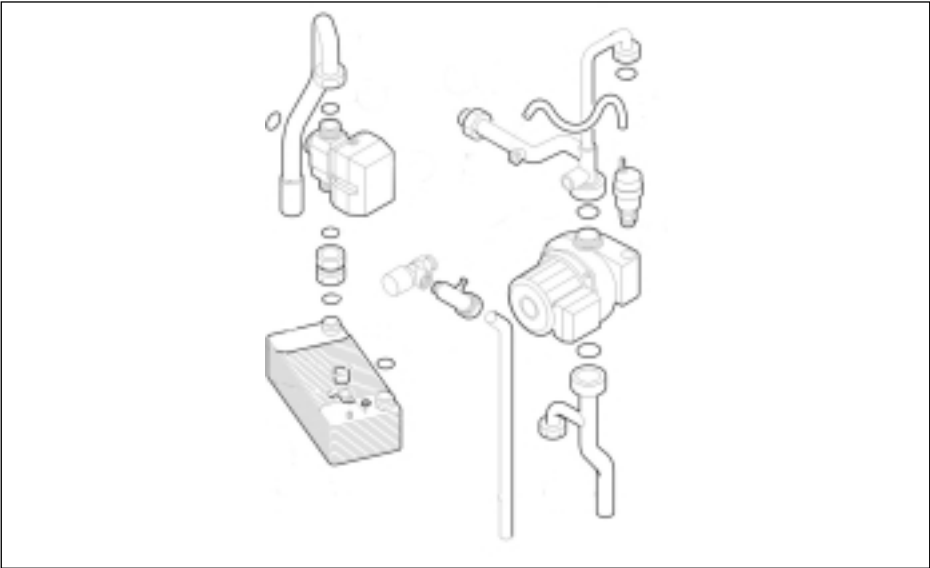
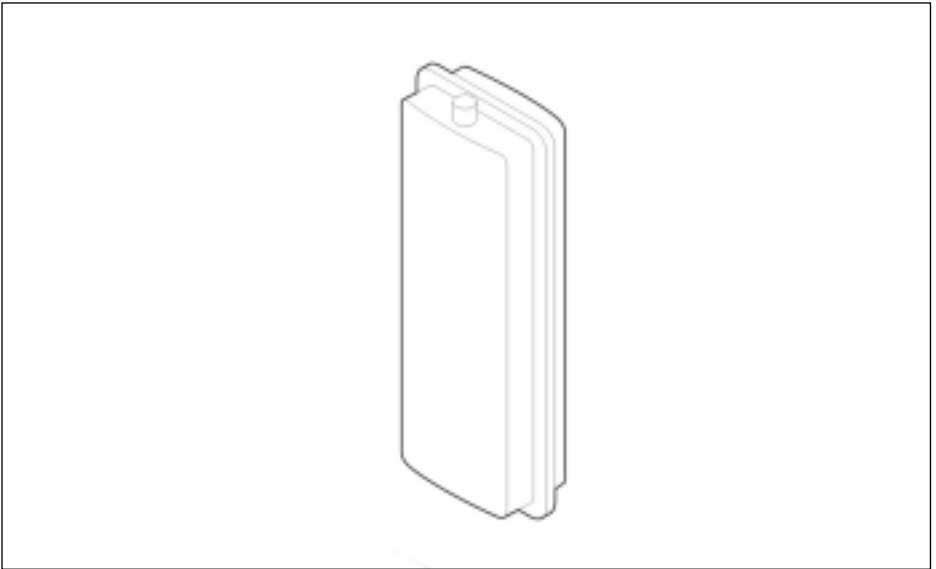

Fig. 28 Checking expansion vessel

pdf

- Isolate the electrical supply.
- Isolate the boilers heating flow and return.
- Remove the boiler front casing cover.
- Drain the boiler until there is no pressure within the boiler.
- Remove the dust cover on the schreder valve located at the top of the expansion vessel.
- Check the pressure within the vessel and if it requires increasing then connect a suitable pump to the schreder valve and increase to a suitable pressure as indicated in *Table 04*.
- Refit the dust cover and recharge the boiler with cold water to a minimum of 0.8 bar pressure.
- Open any isolating valves to the heating flow and return.
- Switch on the electrical supply to the boiler and test fire visually examining for leaks.
- Re-fit front casing cover replacing the gasket if it was damaged during removal.

Note: If the pressure gauge located in the boiler increases sharply when firing and drops when not firing then the expansion vessel could be too small for the volume of water in the heating system and an additional vessel will have to be installed.

11.3 Maintenance

If during the annual inspection combustion results indicate that the boiler is no longer operating at the optimum level, additional maintenance should be carried out as follows:

NOTE:

- Please ensure that the gas supply and mains power supply is isolated before any maintenance work is carried out on the boiler
 - Care should be taken when stripping the boiler for maintenance making sure that all parts nuts, washers and gaskets etc. are kept safe, clean and dry for re-assembly
 - A service gasket set is available please contact Broag for details
 - Following maintenance/cleaning, the boiler should be re-assembled in the reverse order re-placing gaskets and joints where found necessary.
 - All general cleaning should be carried out with a soft brush or damp cloth to avoid damaging components. (Solvents must not be used).
1. Isolate the electrical power supply to the boiler.
 2. Close the boiler gas isolation valve.
 3. Remove the front casing cover by unscrewing the 2 screws and lifting the panel off the top plate.
 4. Remove M5 nuts and bolts securing fan and air inlet assembly to venturi, disconnecting electrical leads where necessary.
 5. Remove M5 retaining nuts securing venturi to front plate.
 6. Remove ignition cap/lead and earth lead from Ignition/ionisation electrode.

7. Cleaning the heatexchanger

- Release the retaining nuts from heat exchanger front plate, remove plate, be careful not to damage the insulation plate or the burner connected to front plate, store safely.

Attention: Check the cord gasket and the insulating plate between the front plate and the heat exchanger. If damaged or hardened they must be replaced.

- Heat exchanger can be washed with clean water, if badly contaminated, clean with a small stiff bristle "bottle type" brush or use the special cleaning tool (supplied optional). Care should be taken when using water in the confined space of the boiler casing to avoid contaminating the electrical controls. Compressed air can also be used but care should be taken to ensure disturbed dust etc does not contaminate the rest of boiler and controls.
- When replacing the heat exchanger front plate – tighten the retaining nuts to a torque of 8,5 Nm.

8. Cleaning the burner assembly

- Clean the burner assembly by using compressed air only - between 2 and 5 bar with the nozzle positioned a min of 10mm away and towards the face of the burner. Check that the retaining M4 screws are tight
- If the burner is removed from the front plate ensure burner retaining screws are tight on re-assembly to a torque of 2 Nm.

9. Cleaning the inspection glass

- Remove the two retaining screws on the inspection glass holder, clean and replace.

10. Cleaning the siphon

- Remove the complete siphon (located underneath heat exchanger)
- Remove siphon bowl clean and refill with clean water and re-fit
- Re-fit siphon to heat exchanger

11. Cleaning the fan

- Use a synthetic brush to clean fan.

Attention: be careful not to disturb the balance clips on the vanes.

12. Cleaning the venturi

- Use a synthetic brush to clean venturi – make sure that the silicon hose between gas valve and venturi is clear and in good condition – replace if necessary.
13. Refit all removed parts in reverse order replacing gaskets where found necessary.
 14. Check for gas leakage.
 15. Put the boiler back in service.
 16. Fire up boiler and check the combustion. Adjust as found necessary (see *Par. 11.2.1 and 11.2.2*)
 17. Complete commissioning/site report and boiler log book.

Heat exchanger cleaning and burner removal

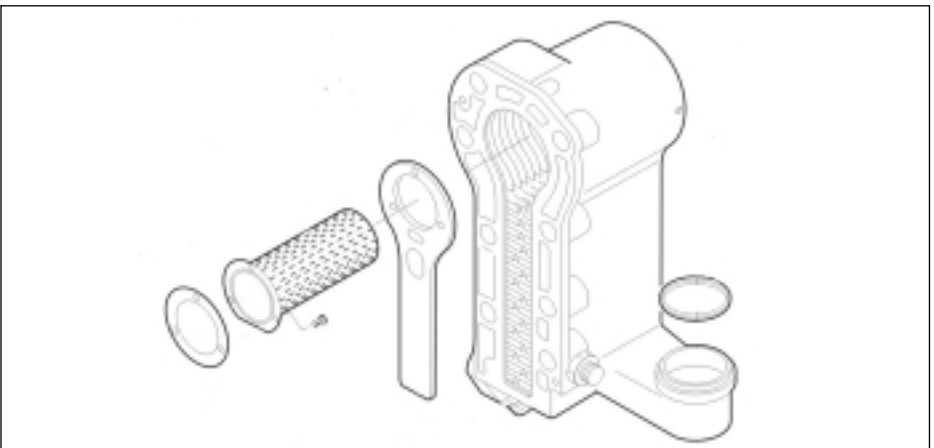

Fig. 29 Heat exchanger cleaning

Procedure:

1. Isolate the electrical power supply to the boiler.
2. Close the boiler gas isolation valve.
3. Remove the front casing cover by unscrewing the 2 screws and lifting the panel off the top plate.
4. Remove the HT cable/cap from the ignition electrode (check and replace if necessary).
5. Disconnect the earth wire from the ignition electrode.
6. Remove, clean and re-set or replace if necessary the ignition electrode and gasket.
7. Disconnect the electrical connection from the fan.
8. Loosen the union nut from the gas pipe on the bottom of the gas block.
9. Release and remove the 9 nuts on the front of the heat exchanger.
10. Remove the front plate from the heat exchanger complete with fan, venturi and burner taking care not to damage the burner face.

Attention: Check the cord gasket between the front plate and the insulating plate between the front plate and the heat exchanger. If either is damaged or hardened they must be replaced.

11. Clean the heat exchanger with the cleaning tool (option - available from Broag).
12. Clean burner assembly with small paint brush or low pressure compressed air.
13. Clean inspection glass.
14. Remove siphon, clean, refill with clean water and re-fit.

To inspect/clean the venturi, disconnect the venturi from the fan:

15. Remove the screws on the inlet side of the fan.
16. Using a soft brush, remove loose dust particles from the venturi and fan before reassembling it.
17. Refit all removed parts in reverse order replacing gaskets where found necessary.
18. Check for gas soundness.
19. Put the appliance back in service.
20. Fire up boiler and re-check the combustion and adjust as necessary (*see Par. 11.2.1 and 11.2.2*)
21. Complete commissioning report.

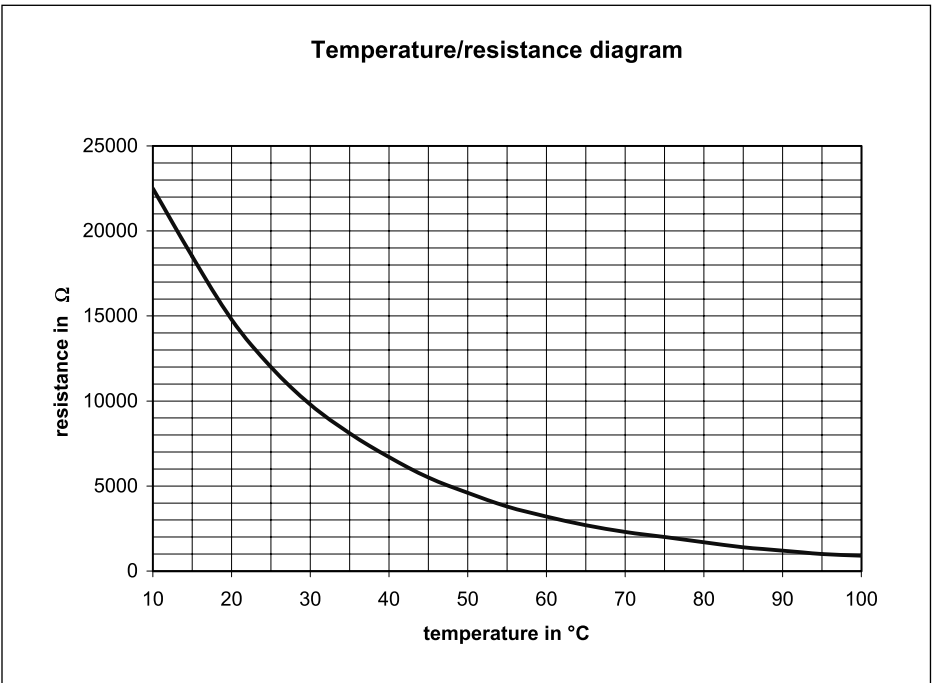

Fig. 30 Sensor resistance graph
pdf

11.4 Part list Selecta system boiler

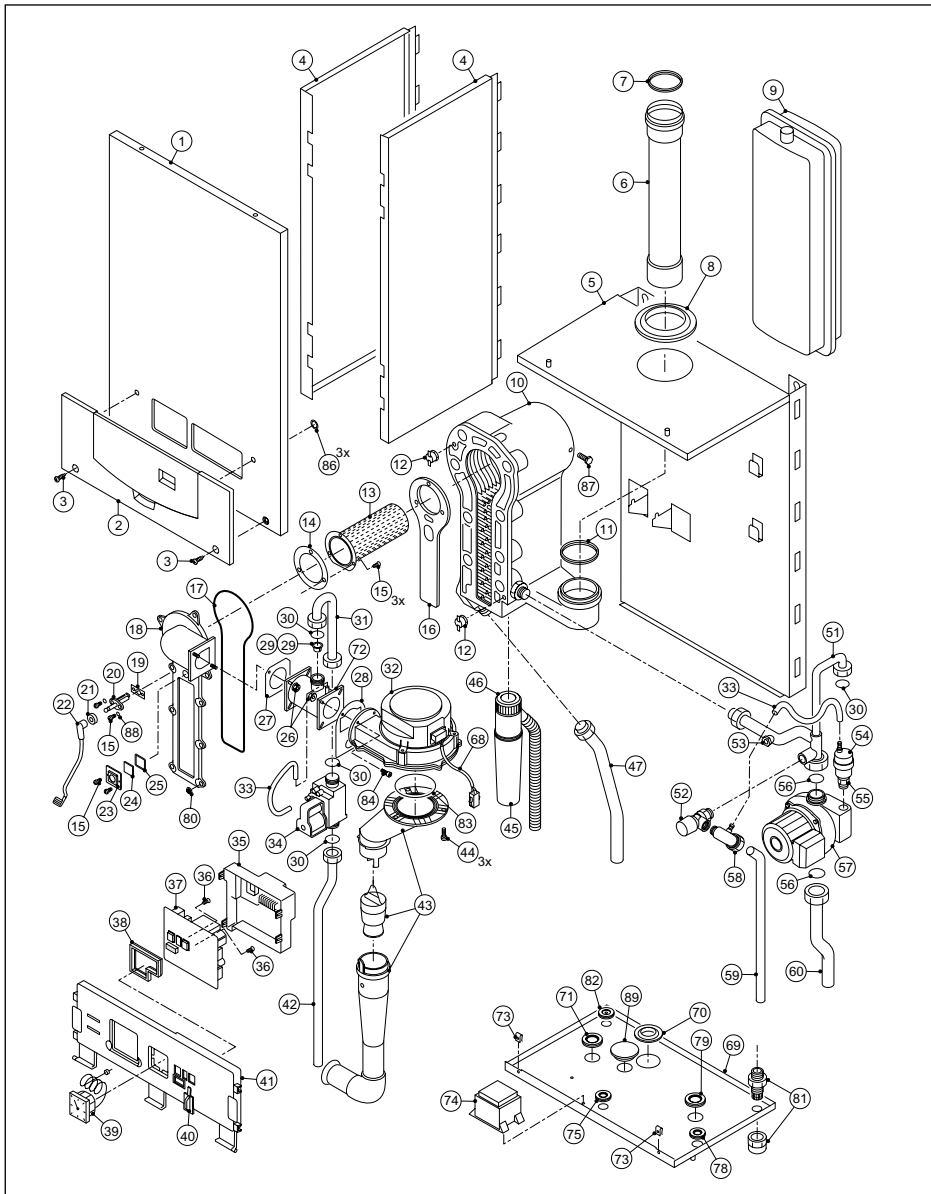
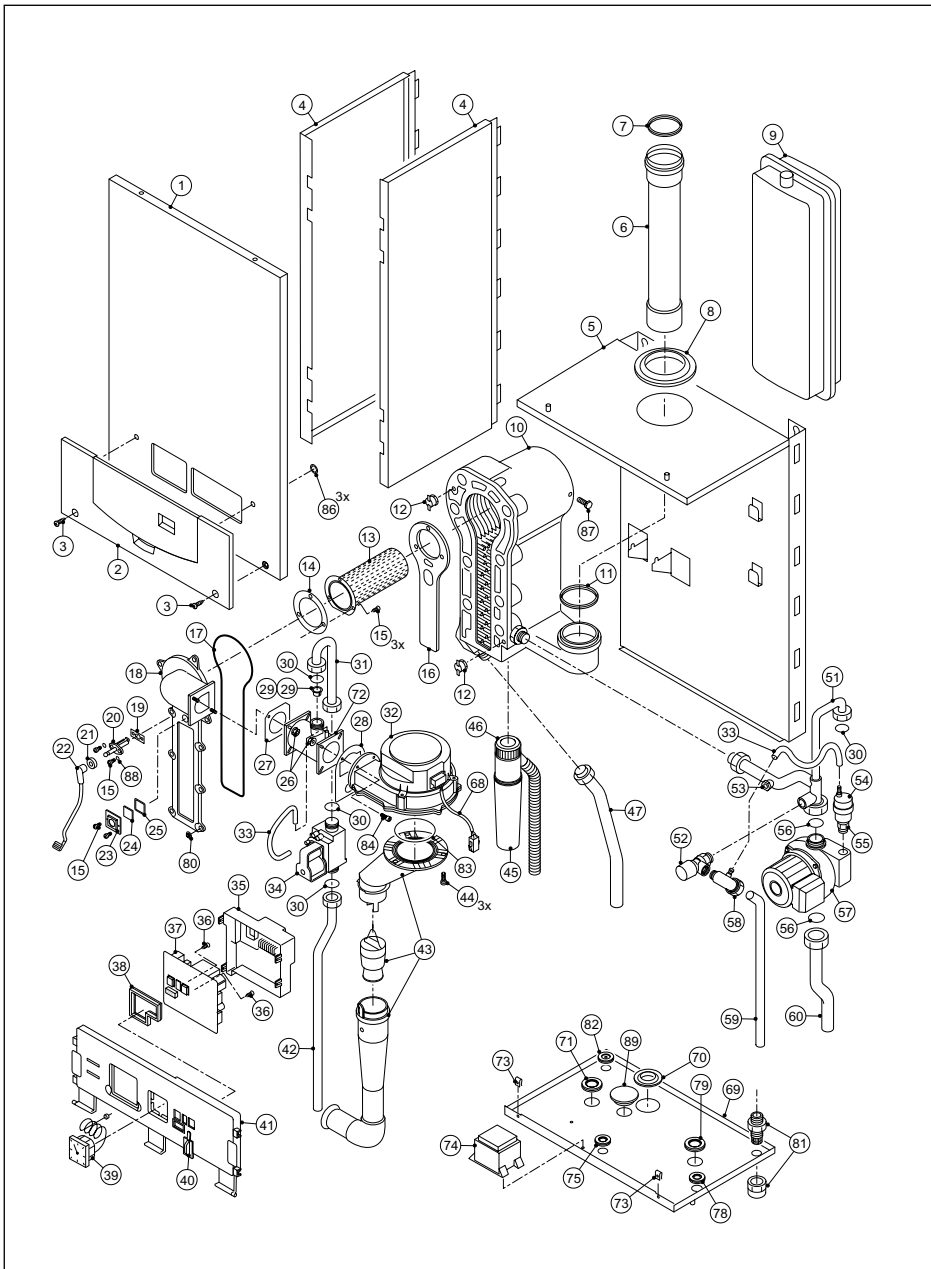

Fig. 31 Selecta system boiler
system boiler pdf

Pos. nr.	Part description	Additional detail
1	Casing front panel	
2	Cover grey plastic	c/w logo and retaining star washers
3	Screw self tapper Phillips 4,2 mm x 19 mm	for front casing x 2
4	Casing side panel	left or right hand/ universal
5	Casing rear and top panel assembly	
6	Flue connection pipe 70/60 mm Ø	
7	Sealing ring Flue connection 60 mm Ø	
8	Grommet 100 mm i/d	flue pipe to top casing
9	Expansion vessel 8,0 Litre	
10	Heat exchanger	
11	Sealing ring 70 mm Ø	flue to heat exchanger
12	Sensor temperature Elmwood NTC 12K/007	flow and return
13	Burner	
14	Gasket	for burner to front plate
15	Screw M4 x 10	for burner to front plate x 3 & site glass x 2
16	Insulation	for front plate
17	Sealing profile	for front plate to heat exchanger
18	Front plate	for heat exchanger
19	Gasket	for electrode
20	Electrode ignition/ionisation MX REBA	incl. gasket and 2 screws
21	Grommet	for electrode cap
22	Cable ignition/ionisation c/w cap and grommet	
23	Mounting frame	for Inspection glass
24	Glass inspection 32 x 32 x 3 mm	c/w gasket and 2 screws
25	Gasket	for inspection glass
26	Nut M5	for venturi to fan and front plate x 4
27	Gasket	venturi to front plate
28	Gasket	fan to venturi
29	Restriction cone Natural Gas Restriction cone kit for LPG	
30	Gasket 23.8 mm o/d x 17.2 mm l/d x 2 mm	for gas valve x 2
31	Pipe assembly gas	for gas valve to venturi
32	Fan assembly EBM G1G 126 AC 13-13	
33	Hose silicone 4 mm i/d-8 mm (per M)	for gas valve to venturi and air vent discharge
34	Valve gas multi block SIT 848 24V ¼"	
35	Cover MCBA control board	
36	Screws self tapper phillips 35 mm x 7 mm	for MCBA cover x 2
37	Control board MCBA1495D S	
38	Sealing profile	MCBA to instrument panel
39	Pressure gauge c/w capillary	
40	Dust cap	for PC/PDA connection



41	Instrument panel only (no fittings)	
42	Pipe gas connection 15 mm o/d	for supply to gas valve
43	Air inlet assembly c/w damper, valve and seal ring	
44	Screw pan head phillips M4 x 12 mm	for air inlet assy to fan x 3
45	Syphon reservoir cup only	
46	Siphon assembly complete	
47	Pipe assembly flow	heat X to system 22 mm o/d
51	Pipe assembly return	pump to heat X to expansion vessel
52	Valve safety pressure relief 1/2"	set to 3 bar
53	Pocket assembly	for pressure gauge connection
54	Vent auto air bleed device 3/8"	
55	Valve Non Return 3/8"	for auto air vent
56	Gasket 30 mm o/d x 12 i/d x 3 mm	pump union x 2
57	Pump	Grundfos UPR15/50 1"
58	Elbow 1/2" / 15 mm	safety valve to discharge pipe
59	Pipe s/v discharge 15 mm	safety valve to discharge outlet
60	Pipe return 22 mm	system to pump
68	Cable set	fan to wiring harness
69	Casing bottom plate (System)	
70	Grommet 46 mm o/d x 22 mm l/d black	condensate pipe to bottom casing
71	Grommet 22 mm Ø red	flow pipe to bottom casing
72	Venturi assembly	
73	Clip raymond 12267	for 4,2 mm Ø front cover screw x 2
74	Transformer CKZ050122517 (24 v)	
75	Grommet 15 mm Ø yellow	gas pipe to bottom casing
78	Grommet 15 mm Ø black	s/v discharge pipe to bottom casing
79	Grommet 22 mm Ø blue	return pipe to bottom casing
80	Nut M6	for front plate to heat exchanger x 9
81	Cable gland APG 11x 6 - 9 FS	mains cable entry
82	Grommet Ø 20 mm black	cable entry
83	O ring 65 mm Ø x 3 mm	air inlet to fan
84	Bolt M5 x 16 mm	fan to venturi x 2
86	Star washers (for retaining grey plastic cover)	for retaining grey plastic cover x 3
87	Bolt M6x16mm	for mounting heat x to frame
88	Washer spring ring 4mm o/d x 3mm l/d	for Ign electrode mtg screws x 2
89	Grommet 30 mm Ø black	blind
-	Cover plate - not illustrated	for pipework connections
-	Cable complete wiring harness - not illustrated	not illustrated
	Cable mains supply - not illustrated	230v - 3core flex c/w cable gland
	Fuses 4 amp - not illustrated	F2, 24 volt, on MCBA
	Fuses 2 amp - not illustrated	F1, 230 volt, on MCBA
	Plug 9.5 mm	bottom casing alongside transformer

Table 14 Part list Selecta system boiler

Pos. nr.	Part description	Additional detail
1	Casing front panel	
2	Cover grey plastic	c/w logo and retaining star washers
3	Screw self tapper Phillips 4,2 mm x 19 mm	for front casing x 2
4	Casing side panel	left or right hand universal
5	Casing rear and top panel assembly	
6	Flue connection pipe 70/60 mm Ø	
7	Sealing ring Flue connection 60 mm Ø	
8	Grommet 100 mm i/d	flue pipe to top casing
9	Expansion vessel 8,0 Litre	
10	Heat exchanger	
11	Sealing ring 70 mm Ø	flue to heat exchanger
12	Sensor temperature Elmwood NTC 12K/007	flow and return
13	Burner	
14	Gasket	for burner to front plate
15	Screw M4 x 10	for burner to front plate x 3 & site glass x 2
16	Insulation	for front plate
17	Sealing profile	for front plate to heat exchanger
18	Front plate	for heat exchanger
19	Gasket	for electrode
20	Electrode ignition/ionisation MX REBA	incl. gasket and 2 screws
21	Grommet	for electrode cap
22	Cable ignition/ionisation c/w cap and grommet	
23	Mounting frame	for Inspection glass
24	Glass inspection 32 x 32 x 3 mm	c/w gasket and 2 screws
25	Gasket	for inspection glass
26	Nut M5	for venturi to fan and front plate x 4
27	Gasket	venturi to front plate
28	Gasket	fan to venturi
29	Restriction cone (natural gas) Restriction cone (propane)	S56227 S57183
30	Gasket 23.8 mm o/d x 17.2 mm l/d x 2 mm	for various joints x 6
31	Pipe assembly	for gas valve to venturi
32	Fan assembly EBM G1G 126 AC 13-13	
33	Hose silicone 4 mm i/d-8 mm (per M)	for gas valve to venturi and air vent discharge
34	Valve gas multi block SIT 848 24V ¾"	
35	Cover MCBA control board	
36	Screws self tapper phillips 35 mm x 7mm	for MCBA cover x 2

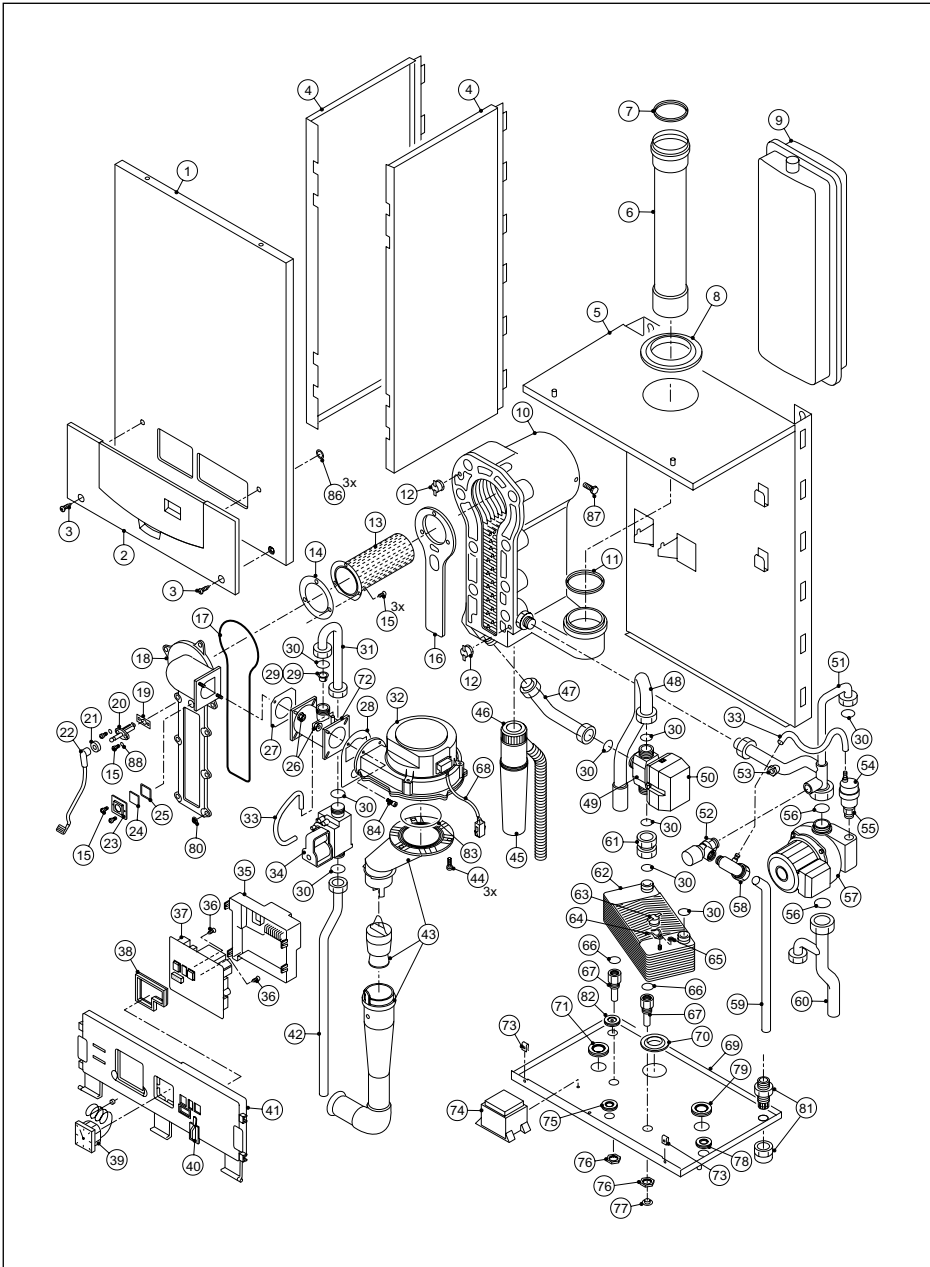

37	Control board MCBA1495D C	
38	Sealing profile	MCBA to instrument panel
39	Pressure gauge c/w capillary	
40	Dust cap	for PC/PDA connection
41	Instrument panel only (no fittings)	
42	Gas connection pipe 15 mm o/d	for supply to gas valve
43	Air inlet assembly c/w damper, valve and seal ring	
44	Screw pan head phillips M4 x 12 mm	for air inlet assy to fan x 3
45	Syphon reservoir cup only	
46	Siphon assembly complete	
47	Pipe assembly flow	heat X to three way valve
48	Pipe flow 22 mm o/d	three way valve to HTG system
49	Body three way valve VCZM6000E	
50	Motor three way valve VC2012ZZ00E	
51	Pipe assembly return	pump to heat X to expansion vessel
52	Safety pressure relief valve ½"	set to 3 bar
53	Pocket assembly	for pressure gauge connection
54	Vent auto air bleed device 3/8"	
55	Valve Non Return	for auto air vent
56	Gasket 30 mm o/d x 12 i/d X 3 mm	pump union x 2
57	Pump	Grundfos UPR15/50 1"
58	Elbow ½" / 15 mm	safety valve to discharge pipe
59	Pipe s/v discharge 15 mm o/d	safety valve to discharge outlet
60	Pipe return 22 mm o/d	system or plate heat X to pump
61	Pipe assembly flow	three way valve to plate heat X
62	Plate heat X for DHW water	
63	Sensor DHW temperature 12k/25gr.	
64	Bracket	for DHW temperature sensor
65	Nut M3	for sensor bracket x 1
66	Gasket 18.3 mm o/d X 12.7mm l/d x 2 mm.	plate heat X secondary unions x 2
67	Union connections 15 mm o/d	DHW flow and return
68	Cable assembly	fan to wiring harness
69	Casing bottom plate (Combi)	
70	Grommet 46mm o/d x 22mm l/d black	condensate pipe to bottom casing
71	Grommet 22 mm Ø red	flow pipe to bottom casing
72	Venturi assembly	
73	Clip raymond 12267	for 4,2 mm Ø front cover screw x 2
74	Transformer CKZ050122517 24v	
75	Grommet 15 mm Ø yellow	gas pipe to bottom casing
76	Nut brass 1/2"x 7mm	for plate heat X unions
77	Flow DHW limit device 10,0 ltr/min.	for plate X DHW flow
78	Grommet 15 mm Ø black	s/v discharge pipe to bottom casing
79	Grommet 22 mm Ø blue	return pipe to bottom casing

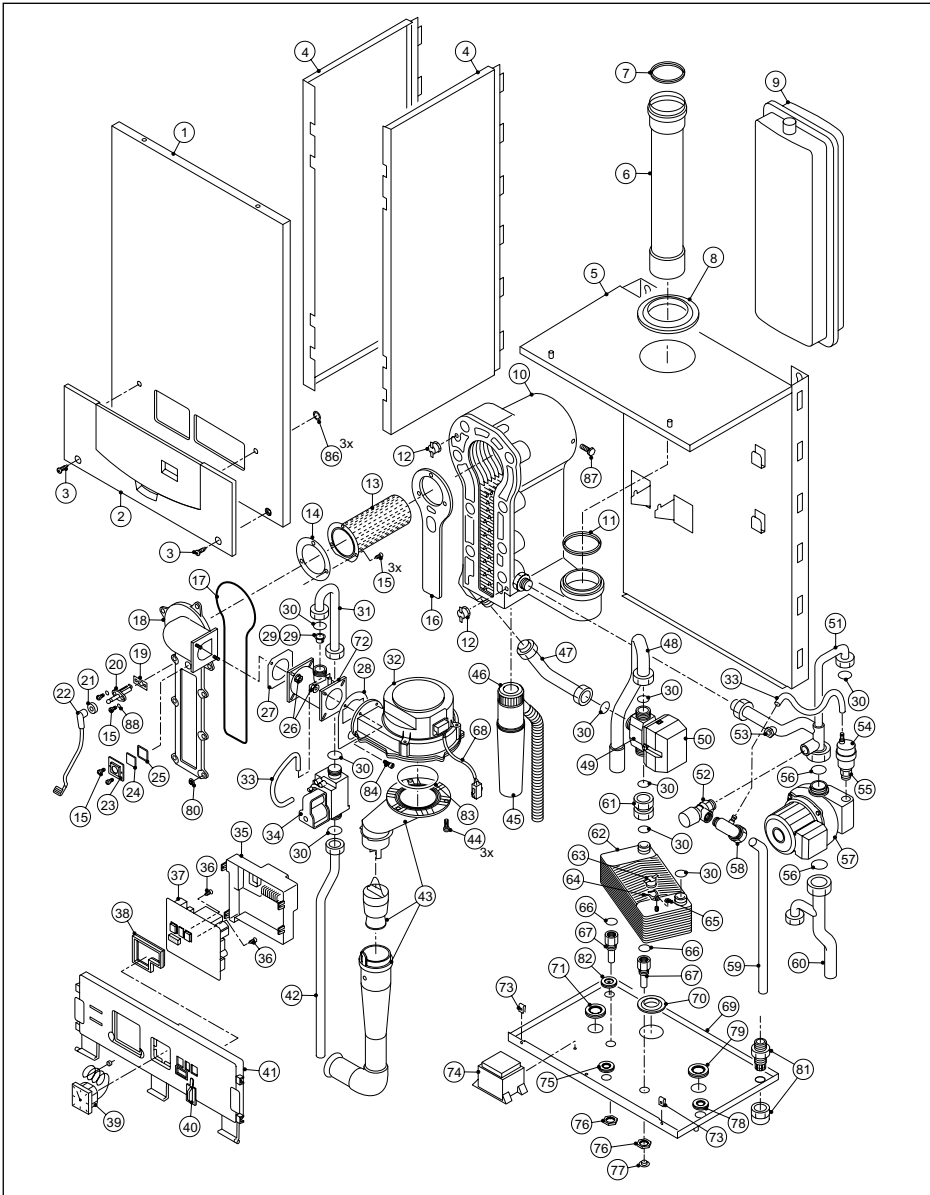

80	Nut M 06	for front plate to heat exchanger x 9
81	Cable gland APG 11x 6 - 9 FS	mains cable entry
82	Grommet Ø20 mm black	cable entry
83	O ring 65 mm Ø x 3mm	air inlet to fan
84	Bolt hex head M5 x 16 mm	fan to venturi x 2
85	Gasket 25 mm o/d x 21mm l/d x 1,0 mm.	for plate heat X cold inlet union
86	Star washers	for retaining grey plastic cover x 3
87	Bolt M6x16mm	for mounting heat x to frame
88	Washer spring ring 4mm o/d x 3mm l/d	for lgn electrode mtg screws
	Cover plate - not illustrated	for pipework connections
	Cable complete wiring harness - not illustrated	
	Cable mains supply - not illustrated	230v - 3core flex c/w cable gland
	Wall bracket for selecta - not illustrated	
	Fuses 4 amp - not illustrated	F2, 24 volt, on MCBA
	Fuses 2 amp - not illustrated	F1, 230 volt, on MCBA
	Plug 9.5 mm	bottom casing alongside transformer

Table 15 Part list Selecta combi boiler

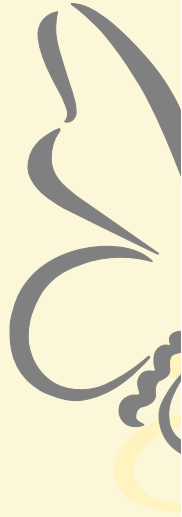

© Copyright

All technical information and drawings contained within this document are the property of Broag-Remeha and shall not be copied without our prior consent in writing.

Broag Ltd.

Remeha House

Molly Millars Lane

RG41 2QP WOKINGHAM, Berks.

Tel: +44 118 9783434

Fax: +44 118 9786977

Internet: uk.remeha.com

E-mail: boilers@broag-remeha.com