



ROBINSON WILLEY

The hottest name in heating

RIVIERA RS & BELVEDERE RS

G C No. 32-170-26

G C No. 32-170-27

Cat I_{2H} - G20 at 20mbar.
For use in GB and IE.

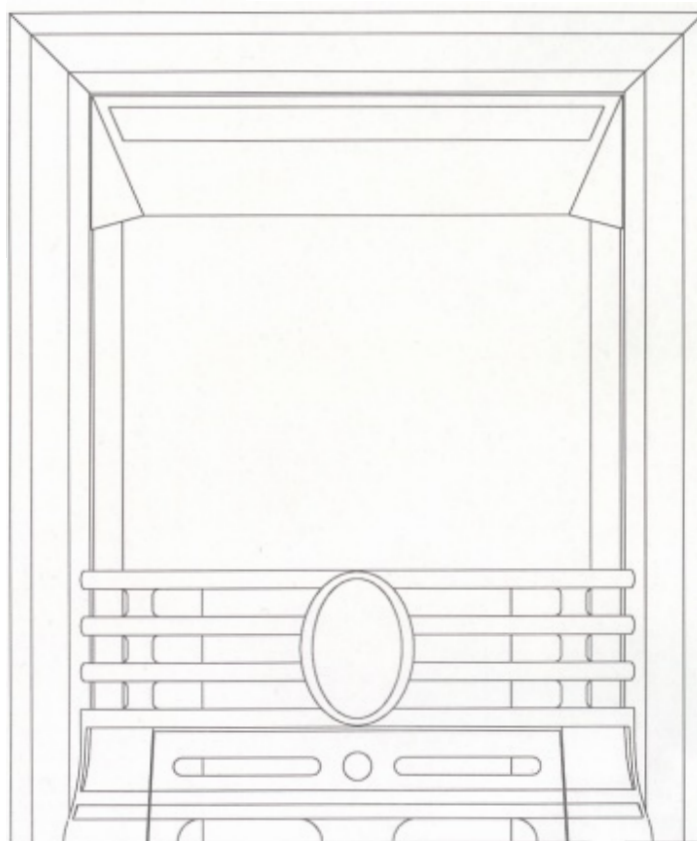

BELVEDERE RS
ILLUSTRATED
(see page 2)

Installation & Servicing Instructions

The Data Badge and Serial Number are located on the left hand side of the base panel.

PLEASE LEAVE THESE INSTRUCTIONS WITH THE USER

This product uses fuel effect pieces containing Refractory Ceramic Fibre (RCF), which are man-made vitreous silicate fibres. Excessive exposure to these materials may cause temporary irritation to eyes, skin and respiratory tract, consequently, it makes sense to take care when handling these articles to ensure that the release of dust is kept to a minimum.

To ensure that the release of fibres from these RCF articles is kept to a minimum, during installation and servicing we recommend cleaning should be carried out in a well-ventilated area or in the open air, by gently brushing with the pieces held away from your face so that you avoid inhaling the dust. We do not recommend the use of a normal domestic vacuum cleaner, which may blow dust back into the air. *If a vacuum cleaner is recommended for use by your organisation, you must use a HEPA filtered vacuum to remove any dust and soot accumulated in and around the fire before and after working on the fire.* When replacing these articles we recommend that the replaced items are not broken up, but are sealed within heavy duty polythene bags, clearly labelled as RCF waste. This is not classified as "hazardous waste" and may be disposed of at a tipping site licensed for the disposal of industrial waste. Protective clothing is not required when handling the articles, but we recommend you follow the normal hygiene rules of not smoking, eating or drinking in the work area and always wash your hands before eating or drinking.

Advise the customer that they should read their Users instructions before operating the fire and always follow the advice in the Section headed "Cleaning your Fire".

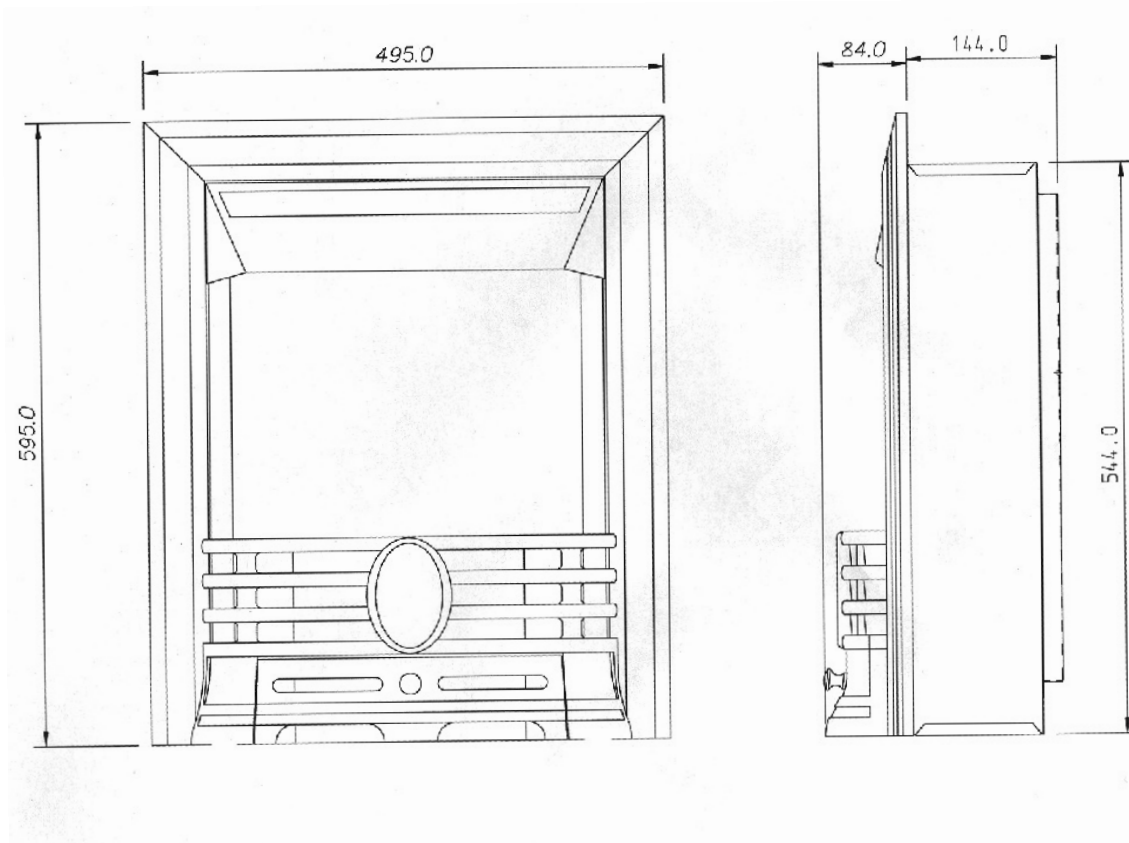

Fig 1 (Belvedere R.S. illustrated).

TABLE OF CONTENTS

No.	SECTION	PAGE
	REFRACTORY CERAMIC FIBRE NOTICE	2
	TABLE OF CONTENTS	3
	TABLE OF FIGURES	3
1.0	DESCRIPTION	4
2.0	INSTALLATION REQUIREMENTS	4
3.0	TECHNICAL DATA	4
4.0	SAFETY	5
5.0	UNPACKING	5
6.0	SITING GENERAL	6
7.0	NON-COMBUSTIBLE WALL INSTALLATION	8
8.0	REBATED SURROUND INSTALLATION	9
9.0	COMBUSTIBLE WALL INSTALLATION	10
10.0	PREPARATION OF HEATER	11
11.0	GAS CONNECTION	14
12.0	COMMISSIONING	14
13.0	GUIDANCE ON FITTING A LINTEL	15
14.0	SERVICING	17
15.0	SPARES AND SERVICE	19
16.0	SHORT LIST OF PARTS	19

TABLE OF FIGURES

No.	DESCRIPTION	PAGE
1	LINE DIAGRAM (BELVEDERE ILLUSTRATED)	2
2	TYPICAL INSTALLATION	6
3	FLUE TERMINAL LOCATION	7
4	CABLE FIXING	8
5	FLUE ASSEMBLY IN TIMBER FRAMED AND COMBUSTIBLE CONSTRUCTION	10
6A	OVERALL FLUE LENGTH	11
6B	FLUE ASSEMBLY INSTALLED	11
6C	EXPLODED DIAGRAM OF FLUE COMPONENTS	11
7	TERMINAL GUARD INSTALLATION	12
8	COALS AND GLASS DOOR INSTALLATION	12
9	REAR ENTRY GAS SUPPLY CONNECTION	14
10	LOAD ASSESSMENT FOR LINTELS	15
11	CUTTING THE SLOT FOR LINTEL	16
12	FITTING LINTEL	16
13	CONSTRUCTING THE OPENING	16
14	GENERAL VIEW OF HEATER CONTROLS	17
15	DETAIL VIEW OF CONTROLS	18

1.0 DESCRIPTION

The Riviera R.S. and Belvedere R.S. heaters are room sealed, inset live fuel effect gas heaters with coals.

The heater can be mounted only on a non-combustible hearth, and can be fitted into a suitable fire surround (rated at 150°C). The heater can be installed on a normal brick wall from the inside of a building making it ideal for rooms where access from the outside is difficult, for example multi-storey buildings. If the heater is to be installed on a combustible wall, then the combustible wall kit, Part No. 994530, must be used together with a 152 mm rebated surround.

Four flues are available:	RW Part No.
Mini (telescopic) flue for walls from 280mm to 353mm	990177
Short (requires cutting) flue for walls from 225mm to 353mm	993241
Medium (telescopic) flue for walls from 353mm to 507mm	993240
Long (telescopic) flue for walls from 507mm to 658mm	993239

The heater is for use on Natural Gas only (G20 at 20 mbar supply pressure).
The appliance data badge is located on the LH side of the base panel.

The following optional extras are available: -	RW Part No.
Combustible Wall Kit	994530
Terminal Guard	994371

2.0 INSTALLATION REQUIREMENTS

Gas Safety (Installation and Use) Regulations).

It is the law that all gas appliances are installed by competent persons in accordance with technical requirements.

The following items relate to this appliance:

1. BS 5871
2. BS 5440
3. BS 6891
4. The Building Regulations issued by the Department of Environment and the Building Standards (Scotland) (Consolidation) Regulations issued by the Scottish Development Department.
5. Any other relevant British Standard Code of Practice and/or Local Building Regulations.
6. Installation must comply with these instructions and be in accordance with the rules in force.

3.0 TECHNICAL DATA

Height	595 mm
Width	495 mm
Depth(rearwards projection)	144 mm
Weight	14.5 Kg (43lbs)
Gas Type	Natural Gas
Max. Heat Input (gross)	3.8 kW
Efficiency	Class 1
Max.Heat Output	2.8kW
Min Heat Input (Econ)	2.0kW
Min Heat Output	1.5kW
Height to Centre Line of Flue	427 mm
Setting Pressure	COLD 17.0mbar ± 1.0 mbar
Supply Pressure	20 mbar
Burner	RW Part No. 989236
Injector	Bray Cat 16/250
Pilot Burner	RW Part No. 822367
Ignition	Piezo spark ignition operated as control tap is turned.
Control Tap / FSD	Concentric TESA 2377/A8
Spark Gap	3 to 4 mm
Control Knob Settings	OFF, PILOT / IGNITION , HIGH, MED, LOW, ECON
Gas Connection	8mm Tube nut & olive into Isolating Elbow (supplied)

4.0 SAFETY

- 4.1 Due to high temperature, the appliance should be located away from furniture and curtains.
- 4.2 Children and adults should be alerted to the hazards of high surface temperature and should stay away to avoid burns or clothing ignition.
- 4.3 Young children should be carefully supervised when they are in the same room as the appliance.
- 4.4 Clothing or other flammable material should not be placed on or near the appliance.
- 4.5 Any safety screen or guard removed for servicing an appliance must be replaced prior to operating the appliance.
- 4.6 Installation and repair should be carried out by a CORGI registered service agent. The appliance should be inspected before use and at least annually by a CORGI registered service agent. More frequent cleaning may be required due to excessive lint from carpeting, bedding material, etcetera. It is imperative that control compartments, burners and circulating air passageways of the appliance be kept clean.
- 4.7 The glass door is of a special heat resisting type, and if damaged must be replaced with the proper spare (see Section 16.0 Short List of Parts).
- 4.8 **WARNING:** Do not operate appliance with the glass front removed, cracked or broken.
- 4.9 **WARNING:** Do not subject the glass door to impact of any kind as breakage may occur.

5.0 UNPACKING

The heater is packed in a carton together with the following items:-

1. Flue pack.
2. Gasket pack comprising flue and air duct gaskets.
3. Pack of fittings comprising:

No.	Description	RW Part No.
4	Cable fixing eyelets	822006
4	Woodscrews No. 10 x 38mm	810240
4	Brackets-rebated surround	989237
4	No. 8 Self Tapping Screws x10mm	810490
4	Wall plugs	820343
2	Fixing cables	992424
2	Cable adaptors	994839
2	Grub screws	810940
3	M4 x 10mm Taptite screws (air duct)	810327
2	No. 6 Self Tapping Screws x 10mm	810776
4. Foam seal pack.
5. Flue sealing tape.
6. A template representing the backplate full size; indicating the positions of the air inlet duct and eyelet screw positions.
7. The Coals pack.
8. Fender/Ashpan pack

Remove the items and keep in a safe place. Lay the heater on its back in a safe place.

Having opened the top flaps of the carton, the flue pack should be removed along with items 2, 3, 4,5 and 6.

Lift off the carton and remove the heavy fender/ashpan pack from the base, in front of the fire.

Lift the fire clear of the base pack. Remove the decorative trim from around the fire, by pulling the lower sides off the retaining magnets and lifting clear of the top of the fire. Put this safely to one side. Remove the glass door (see Section 10) and remove the coals pack from inside the firebox. Place the glass door and coals pack safely to one side also.

6.0 SITING GENERAL

The heater can only be mounted on a non-combustible hearth at least 700 mm wide by 300 mm deep with the heater central. Its top surface should preferably be 50 mm above the floor level to discourage the placing of rugs or carpets over it.

The heater can be installed in the inner leaf of a suitable external wall, requiring a cut-out 560 mm high by 420 mm wide, ensuring that the wall above is properly supported using the appropriate lintel. (see Section 13.0 Guidance on Fitting a Lintel). The heater can be fitted into a fire surround having a cut-out 560 mm high by 420 mm wide. The material of the surround must have a 150°C application i.e. marked with the suffix '150'

If it is not feasible to cut an opening in the wall then a rebated surround with a 152 mm rebate should be used, to enable the heater to be fixed to the inner face of the wall. If the wall is constructed from combustible materials, either wholly or partially, then the combustible wall kit Part No. 994530 and a 152 mm rebated surround MUST be used. (see Section 8.0 Rebated Surround Installation and Section 9.0 Combustible Wall Installation).

NOTES :

1. When installing the heater using a 152 mm rebated surround, the hearth depth must be increased by 152 mm also.
2. When fixing the flue length, the wall thickness must be measured from the inner face of the fire surround (Refer to Section 10 Preparation of heater).

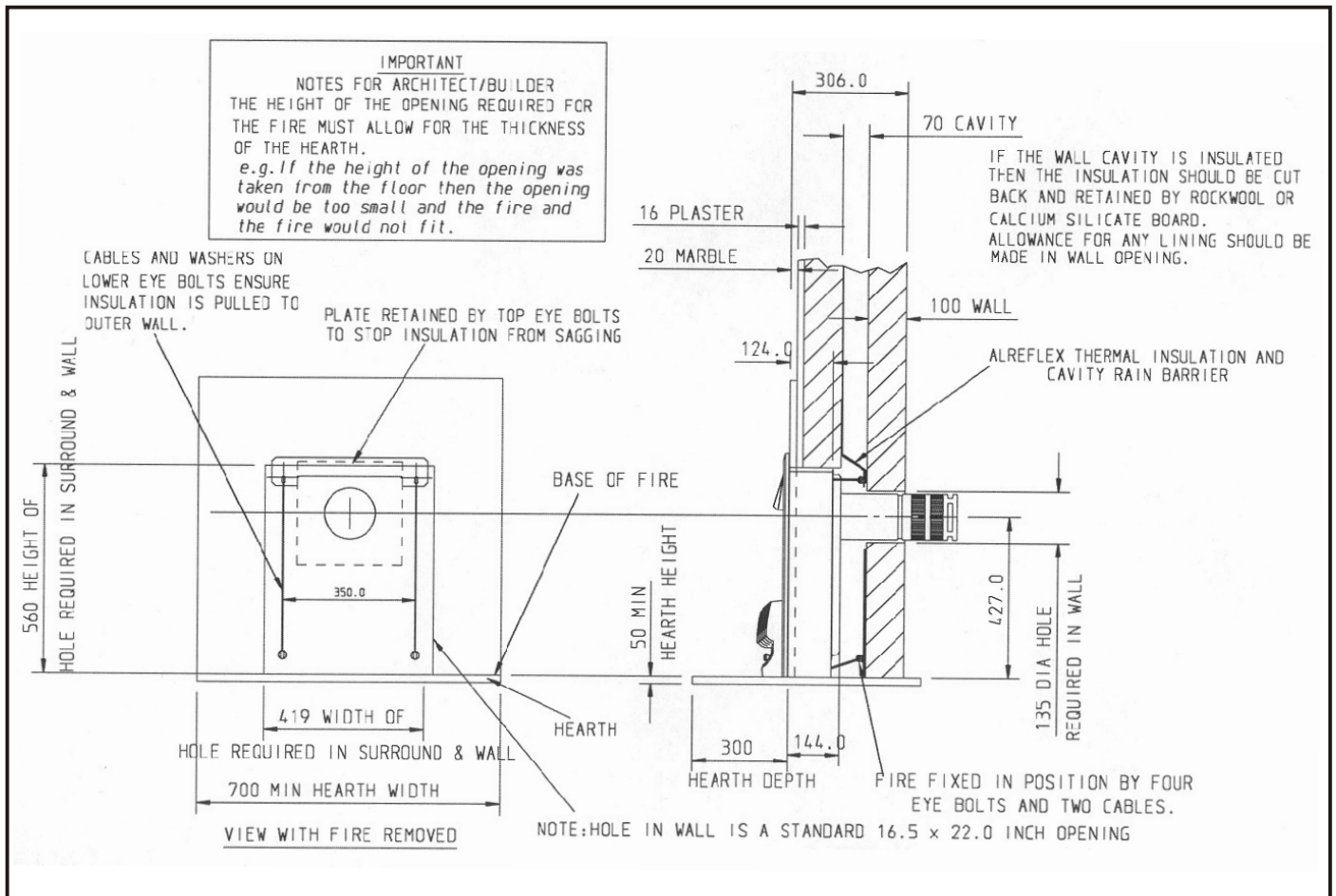

Fig 2

6.1 Siting The Heater

Outside (Fig. 3): Check that the terminal location complies with the requirements of the table below.

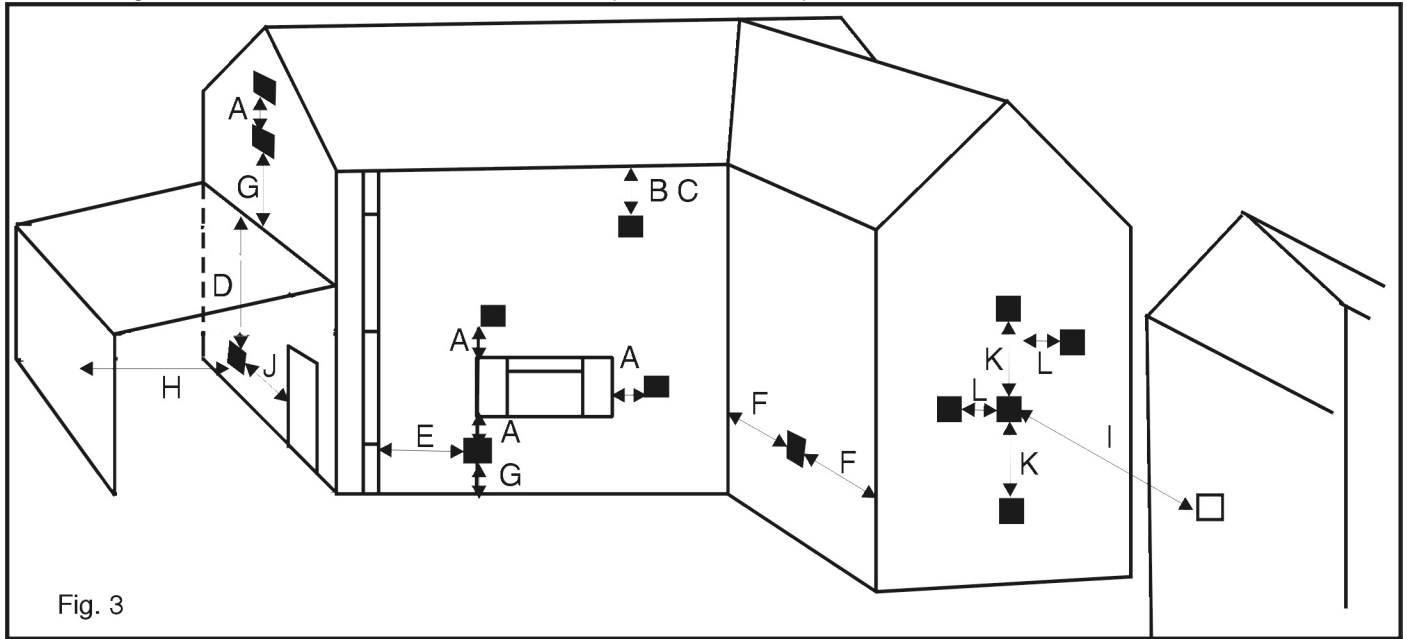

Fig. 3

TERMINAL POSITION	MINIMUM DISTANCE
A - Directly below, above or to the side of an openable window or other opening e.g. air brick	300mm
B - Below gutters, soil pipes or drain pipes	300mm
C - Below eaves	300mm
D - Below balconies or car port roof	600mm
E - From vertical soil pipes or drain pipes	300mm
F - From internal or external corners	600mm
G - Above ground, roof or balcony level	300mm
H - From a surface facing a terminal	600mm
I - From a terminal facing a terminal	600mm
J - From an opening in the car port (e.g. door, window) into dwelling	1200mm
K - Vertically from a terminal on the same wall	1500mm
L - Horizontally from a terminal on the same wall	300mm

Note that in England and Wales the Building Regulations require a terminal guard to be fitted if the terminal is less than 2m (6ft 6in) from the level of any ground, balcony, flat roof or place to which any person has access and which adjoins the wall in which the outlet is situated. A suitable guard assembly is available from Robinson Willey Limited. The part number is 994371. In Scotland, although the Building Standards (Scotland) do not require a terminal guard to be fitted, the fitting of a guard as detailed above is recommended.

INSIDE CLEARANCES :

1. Allow 150mm access at each side of the heater for servicing.
2. Curtains must be at least 230mm clear of the top of the heater and 150mm at the sides and must not be closeable over the front of the heater.
3. A wooden or combustible shelf may be fitted above the heater provided that it complies with the dimensions shown in the diagram. No combustible shelf may be fitted below the minimum of 180mm.
4. The minimum clearance to combustible sides must comply with the dimensions in the diagram. A minimum clearance to adjacent combustible walls, of 500mm, is required from the side of the fire.

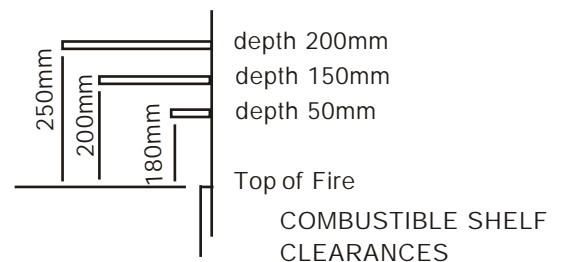

7.0 NON-COMBUSTIBLE WALL INSTALLATION

NOTE: The following instructions relate to normal brick walls. If the wall is wholly or partly of combustible material, the heater can not be installed by this method (see Section 9.0. Combustible Wall Installation). Check the wall thickness. Four different sizes of flue are available for wall thickness up to 658 mm as shown below.

	RW Part number
Mini (telescopic) flue for walls from 280mm to 353mm	990177
Short (requires cutting) flue for walls from 225mm to 353mm	993241
Medium (telescopic) flue for walls from 353mm to 507mm	993240
Long (telescopic) flue for walls from 507mm to 658mm	993239

When fixing the flue length, the wall thickness must be measured from the inner face of the fire surround (Refer to Section 10 Preparation of heater).

- 7.1 Create an opening in the wall, in the position required, 646 mm high x 576 mm wide, ensuring that the wall above the opening is properly supported using the appropriate lintel (see Section 13.0 Guidance on Fitting a Lintel).
- 7.2 Position the template supplied on the inner face of the outer section of the wall ensuring that its top is level and that the centre line of the flue is 427mm above the hearth level.
- 7.3 Cut the hole for the flue making sure that it is straight and level. This can be done with either a 135 mm diameter core drill or hammer and chisel. If neatly drilled no making good is necessary. If not it will be necessary to make good the hole at the terminal end where the flue seal will be located to seal the gap.
- 7.4 Use the template to mark the cable fixing eyelet positions (see Fig 4.). Drill the four fixing holes to a minimum depth of 57 mm using 6 mm diameter masonry drill and insert the plugs.
- 7.5 Screw the cable fixing eyelets into the wall plugs ensuring that they are positioned so the cable can run vertically. Continue as detailed in Section 10 - Preparation of heater.

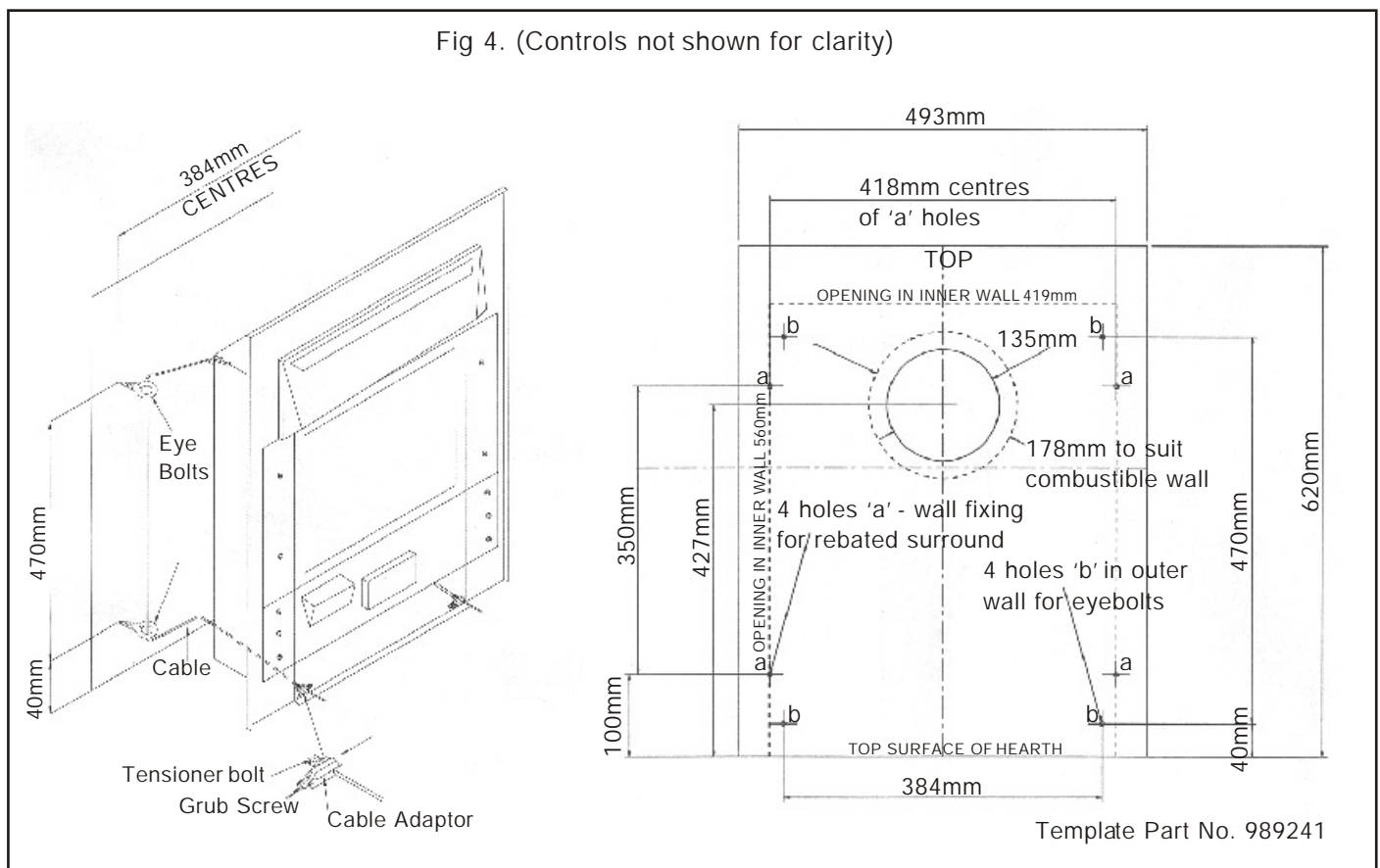

8.0 REBATED SURROUND INSTALLATION

NOTE: The following instructions relate to walls where it is not feasible to cut an opening into the wall. The installation will require a 152 mm rebated surround. If the wall is wholly or partly of combustible material then the combustible wall kit RW Part No. 994530 must be used (see Combustible Wall Installation Section 9.0). Check the wall thickness. The following lengths of flue, up to 658 mm, are available and must be ordered specifically.

	Part number
Mini (telescopic) flue for walls from 280mm to 353mm	990177
Short (requires cutting) flue for walls from 225mm to 353mm	993241
Medium (telescopic) flue for walls from 353mm to 507mm	993240
Long (telescopic) flue for walls from 507mm to 658mm	993239

When fixing the flue length, the wall thickness must be measured from the inner face of the fire surround (Refer to Section 10 Preparation of heater).

All other relevant installation requirements apply (see Section 2.0 Installation Requirements.)

- 8.1 Position the template supplied on the face of the wall ensuring that its top is level and that the centre line of the flue is 427mm above the hearth level. Mark the four fixing bracket positions (see Fig 4.).
- 8.2 Cut the hole for the flue making sure that it is straight and level. This can be done with either a 135 mm diameter core drill or hammer and chisel. If neatly drilled no making good is necessary. If not it will be necessary to make good the wall at both ends of the hole.
- 8.3 Drill the four fixing holes to a minimum depth of 57 mm using 6 mm diameter masonry drill and insert the plugs.
- 8.4 Screw the four fixing brackets supplied to the wall ensuring that they are positioned with the return flange pointing outwards.
- 8.5 Do not lie the heater face down without taking precautions to protect the front face from marking or damage, when fitting the flue system.
- 8.6 Fit the flue and air ducts to the back of the heater using the gaskets and screws provided. This operation is made easier by using the screws to tap the holes before assembly. The four screws for the flue duct are already fitted to the heater. The flanges of the ducts are marked 'TOP' to indicate the way in which the ducts are to be fitted. Note: DO NOT remove the two middle slotted screws.
- 8.7 Adjust the flue length: First measure the wall thickness and add 148 mm to give the overall length of flue 'A' (see Fig 6A.) Fit the terminal assembly to the ducts already fitted to the heater. The top of the assembly is marked 'TOP'. Set the overall length of the flue to the dimension 'A'. Drill 2.7 mm diameter for the fixing screws and secure it with the screws provided. Seal the joint using the self-adhesive tape provided.

NOTES:

- (i) If rear entry gas supply connection is required, then it MUST be installed prior to the installation of the heater (see Section 11.1 Rear Entry Gas Connection).
 - (ii) If front entry gas supply connection from the left or right side is required, then it MUST be installed after the installation of the heater (see Section 11.2 Front Entry Gas Connection).
 - (iii) An isolation elbow is fitted to the inlet gas supply of the heater.
- 8.8 If fitting to a non-combustible wall, with a 135 mm diameter hole, then the cavity must be sealed from the room by fitting the additional foam seal supplied, around the flue, approximately 190mm from the heater connection.
 - 8.9 Remove the tape from the foam sealing strip(s) on the flue. Do not remove the tape before the heater is ready to be installed as the foam strip commences to expand once the tape is removed. The rate of expansion however, is low and there will be adequate time to install the heater, after which the foam strip will continue to expand and fill the gap between the flue and the wall. If for any reason the sealing strip has already expanded before the heater is installed, it can simply be compressed by hand until it is flush with the surface of the flue.
 - 8.10 Insert the flue into the opening in the wall created for the flue. Push the heater back towards the wall until the 'V' notch in the fixing brackets line up with the back panel of the heater. Fix in position with the self tapping screws provided.
 - 8.11 Slide the 'marble' into position between the heater fixing brackets and the seal on the back of the heater, taking care not to damage the seal. Check the dimension from the face of the marble to the face of the wall.
 - 8.12 Offer up the 152 mm rebated surround to the wall and fix in position.

9.0 COMBUSTIBLE WALL INSTALLATION

- 9.1 For installation on walls constructed or comprising combustible materials, reference should be made to the requirements of BS 5440 and the Building Regulations.
- 9.2 Timber Framed Housing: For a timber framed house, the fire can be installed as directed in The Institute of Gas Engineers Utilization Procedure IGE/UP/7 GAS INSTALLATIONS IN TIMBER FRAME BUILDINGS.
- 9.3 The combustible wall kit is suitable for walls in which the combustible part is not more than 195 mm thick measured from the inside of the building.
- 9.4 The combustible wall kit required is Part No. 994530. If the whole of the wall is of combustible material, the outer wall plate must be used, requiring access to the outside of the building.
- 9.5 If the screws and the wall plugs supplied are not suitable for a particular application, proprietary cavity wall fixings may be used.
- 9.6 Proceed as detailed in Section 8.0 Rebated Surround Installation EXCEPT for the following points: -
- (a) Cut the hole for the flue to a diameter of 178 mm through the plaster board taking care not to damage the Vapour Control Layer (VCL).
 - (b) Cut the VCL 10 mm less in diameter than the hole just cut in the plasterboard. This will ensure a seal around the flue liner.
 - (c) Continue the 178 mm diameter hole through the remainder of the combustible material. If the outer leaf of the wall is constructed of non-combustible material then cut the hole 135 mm diameter making allowances for the shrinkage of the timber frame.[†]
 - (d) Measure the thickness of the combustible part of the wall and cut the flue liner to this length, cutting off the end without the fixing brackets. Fit the liner to the sealing plate using the screws provided.
 - (e) Push the liner through the VCL taking care not to damage the VCL, and ensuring that the liner DOES NOT protrude into the cavity by more than 10 mm.
 - (f) If the wall is wholly of combustible material, install the outer wall plate centrally over the hole from the outside as shown in the diagram below. It is recommended that a silicone sealing compound is applied to the inner face of the wall plate to provide a watertight installation.
 - (g) Fit the flue, see Sections 8.7 and 8.8. NOTE: When determining the flue length, measure the wall thickness from the face of the outer wall plate.
 - (h) Slide the rope seal over the flue, until it touches the back of the heater, prior to removing the tape from the flue foam sealing strip.
 - (i) Before installing the flue into the wall is necessary to provide a moisture barrier around the flue at the point which will be in the centre of the cavity. Either of the following methods are acceptable: -
 - (i) Wrap a wire which will not cause corrosion tightly around the flue.
 - (ii) Form a bead of mastic or silicone around the flue.

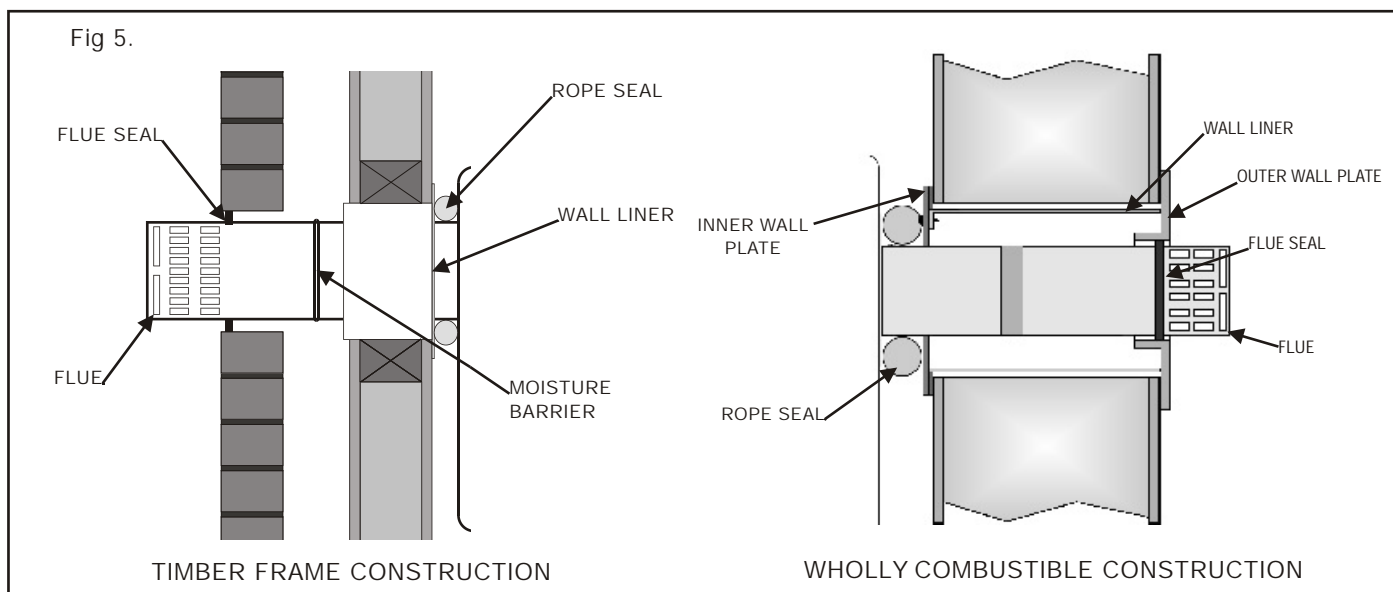

† Note: It is not necessary to allow for shrinkage of timber frames in existing buildings where the necessary length of time has elapsed to allow for any contraction of the timber frame.

10.0 PREPARATION OF HEATER

10.2 Fit Flue

- (a) Do not lie the heater face down without taking precautions to protect the front face from marking or damage, when fitting the flue system.
- (b) Fit the flue and air ducts to the back of the heater using the gaskets and screws provided. This operation is made easier by using the screws to tap the holes before assembly. The four screws for the flue duct are already fitted to the heater. The flanges of the ducts are marked 'TOP' to indicate the way in which the ducts are to be fitted. Note: DO NOT remove the two middle slotted screws.

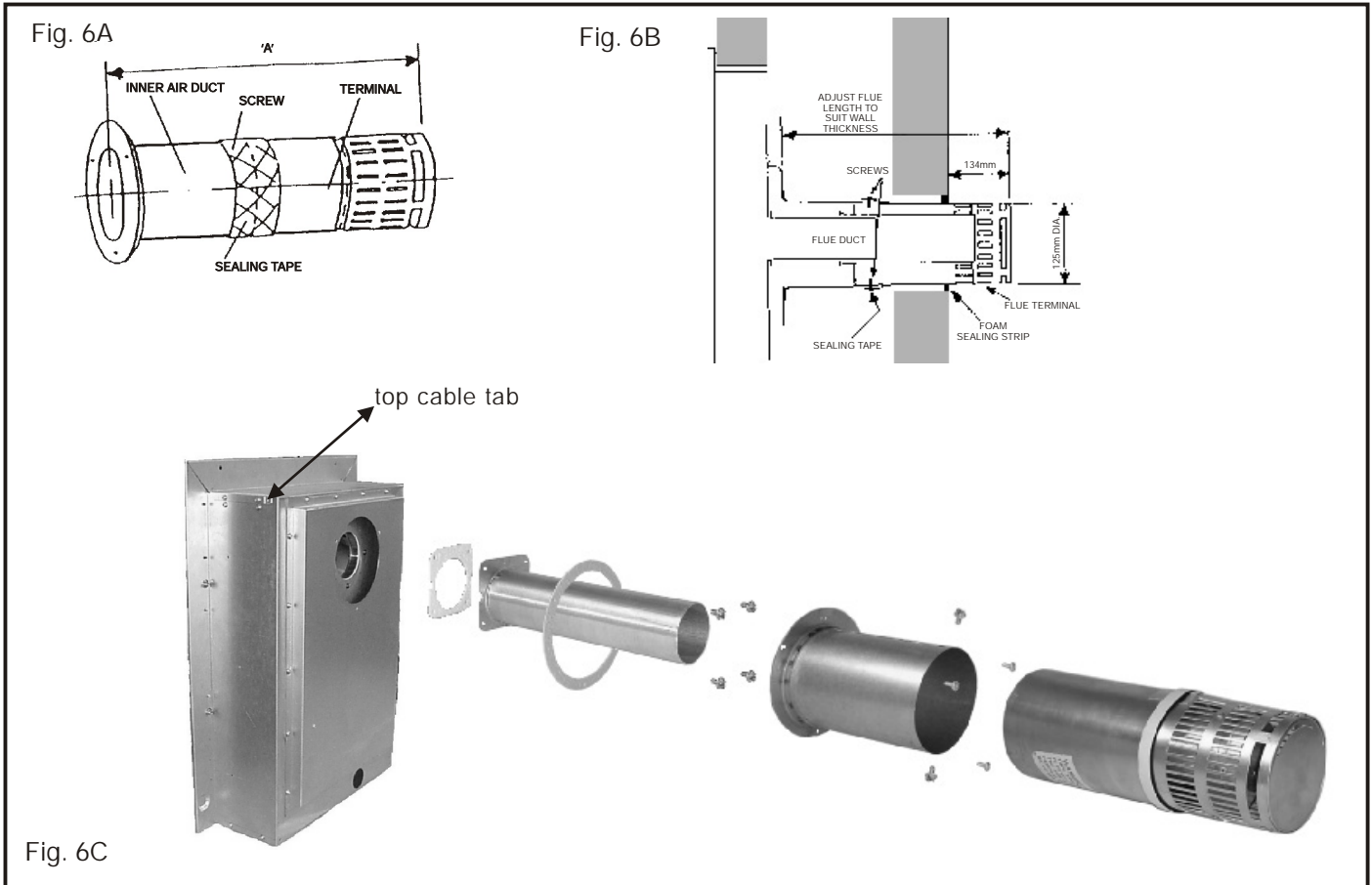

- (c) Adjust the flue length: First measure the wall thickness to give the overall length of flue 'A'. Fit the terminal assembly to the ducts already fitted to the heater. The top of the assembly is marked 'TOP'. Set the overall length of the flue to the dimension 'A' (Fig. 6A). Drill 2.7 mm diameter for the fixing screws and secure it with the screws provided. Seal the joint using the self-adhesive tape provided.

IMPORTANT NOTES:

- (i) If rear entry gas supply connection is required, then it MUST be installed prior to the installation of the heater into the wall (see Section 11.1 Rear Entry Gas Connection).
 - (ii) If front entry gas supply connection from the left or right side is required, then it MUST be installed after the installation of the heater into the wall (see Section 11.2 Front Entry Gas Connection).
 - (iii) An of isolation elbow is fitted at the inlet to the heater.
- (e) Prise the tabs up on each side of the firebox using a screw driver. Fit the cable tensioning bolts into the fire from the front, i.e. Hexagon head inside the fire. Insert the free end of each cable through the respective hole in the firebox and then through the eye screws. Thread the free ends of the cable through the holes in the tensioning bolts from the rear. insert the fire into the opening so that the seal on the back of the fire is compressed against the face of the fireplace/surround. Any visible gaps indicate a deviation from flatness of the surround face which MUST be corrected. Pull the cable taut each side of the fire and insert the cable adaptors over the ends of the cable. While keeping the cable taut slide the adaptor against the tensioning bolt and tighten the grub screw to lock the cable. Using a spanner unscrew each tensioning bolt by about 20mm to tension the cable. Prevent the cable adaptors from rotating while unscrewing the tensioning bolts. DO NOT cut the ends of the cables, but coil them up to facilitate refitting of the fire after servicing.
 - (f) Remove the tape from the foam sealing strip on the terminal. Do not remove the tape before the heater is ready to be installed as the foam strip commences to expand once the tape is removed. The rate of expansion however, is low and there will be adequate time to install the heater, after which the foam strip will continue to expand and fill the gap between the flue and the wall. If for any reason the sealing strip has already expanded before the heater is installed, it can simply be compressed by hand until it is flush with the surface of the flue.

Fig 7.

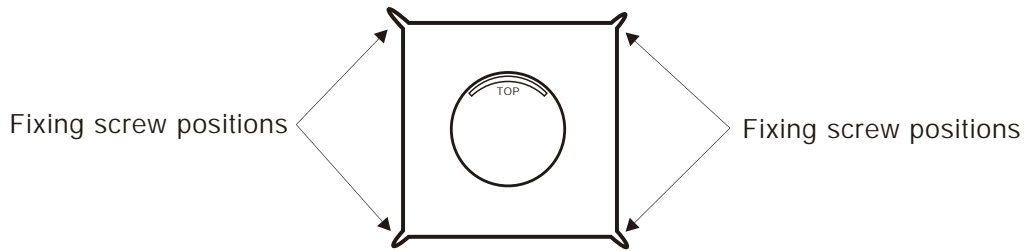

- (g) Insert the heater into the opening, ensuring that the flue is inserted into the hole in the outer section of the wall. Push the heater back against the wall and pull each fixing cable taut. Thread the cable adaptors onto the cables and slide up to the tensioning bolts. While keeping the fixing cables taut, tighten the grub screw in the cable adaptors so that it grips the fixing cable. (see Fig 4.)
- (h) Using a spanner, unscrew each tensioning bolt by approximately 20 mm to tension the cable. Prevent the cable adaptors from rotating while unscrewing the tensioning bolts.
- (i) Coil excess cable and locate in base of fire.
- (j) If a terminal guard is required (optional extra RW Part No. 994731) fit it with the kit supplied ensuring that it is positioned as shown in Fig 7.

10.3 Install Coals



Rear Coal - 1 off

Base Coal - 1 off

Loose Coals - 6 off

Front Coal LH - 1 off

Front Coal RH - 1 off

Fig 8

Fig 8a



Fig 8b



1. Locate the coal base in the burner rim

2. Slide the rear coal down against the rear of the fire, where it sits on the coal base

Fig 8c



Fig 8d



3. The front coals interlock and must be fitted in the correct order
Feed in the front RH coal, decorative face forward, until it sits on the coal base and is positioned forward by its spacers.
Repeat for the LH front coal.

4. Position the six loose coals in their locations in the front coals and the coal base, and resting on the ledge of the rear coal

10.4 Replace Glass Door and finalise



Fig 8e

Replacement is the reversal of removal. Position the top edge centrally against the fire and slide upwards. When meeting resistance of clip swing bottom inwards to mate with face of fire. Hold in place and fit fixing screws.

Finally, refit decorative trim by hooking over top of fire and swing lower sides down to attach to magnets
Position fender and ashpan centrally in front of fire..

11.0 GAS CONNECTION

11.1 Rear Entry Gas Supply Connection

IMPORTANT NOTE: If rear entry gas supply connection is required, then it **MUST** be installed prior to the installation of the heater into the wall. If any pipe is run in or through the cavity, a factory sleeved pipe must be used and sealed where the pipe enters the fire and/or cavity.

- (a) Position the gas supply pipe at the left hand side of the opening and fit the appliance inlet elbow which has a nut and olive suitable for 8mm pipe(see fig 9.). After the heater has been installed into the wall connect the appliance inlet elbow to the gas inlet pipe.

11.2 Front Entry Gas Supply Connection

IMPORTANT NOTE: If front entry gas supply connection is required, then it **MUST** be installed after the installation of the heater into the wall.

- (a) Loosen the nut on the appliance inlet elbow which is located at the lower left hand side of the appliance and turn the elbow to face either left or right as required.
- (b) Connect the gas supply to the appliance inlet elbow which has a nut and olive suitable for 8mm pipe..

11.3 Test for Gas Soundness. (Refer to BS 6891)

The gas installation, including the meter, should be inspected and tested for soundness and purged.

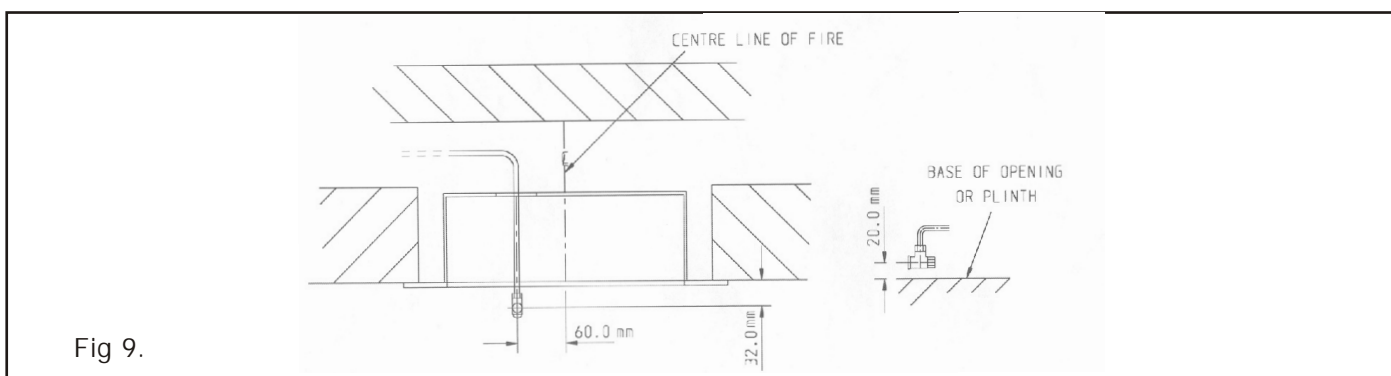

Fig 9.

12.0 COMMISSIONING

12.1 Check the Gas Pressure and F.S.D. Operation

Remove the pressure test point sealing screw and connect a pressure gauge to the test point.

- (a) Light the heater. Please refer to the Users Instructions. Turn the control knob to the full on position marked HIGH.
- (b) Check that the burner pressure is as specified on page 3. Turn off the gas supply to the heater. Wait 3 minutes then restore the gas supply. The pressure should read ZERO to confirm the FSD has shut off the gas. You may hear the FSD close, but you must confirm gas has stopped flowing. Remove the pressure gauge and replace the pressure test screw. Re-light the heater and test for gas soundness around the sealing screw using a suitable leak detection fluid.
- (c) Check ignition performance.

WARNING: If you want to re-light a hot heater wait three minutes before doing so.

12.3 Instruct User (Refer to the Users Instructions)

Make sure that the user understands the following:-

- (a) How to light and operate the heater.
- (b) Demonstrate the removal and replacement of the glass door and the removal and replacement of the ceramics. Advise on the need to clean these items regularly.
- (c) Advise that for safe and efficient operation, the heater should be serviced annually by a CORGI registered service agent.
- (d) When the heater is first lit a slight smell may be noticed but this will quickly clear away with use.

Hand over these instructions to the user.

13.0 GUIDANCE ON FITTING A LINTEL

- 13.1 This section only applies to installations where an opening has to be cut, or is being built into, the inner leaf of the cavity wall (see Section 7.0 Non-Combustible Wall Installation).
- 13.2 To support the wall above the opening, a suitable lintel must be inserted across the top of the opening. If fitting into a cavity wall, a lintel 876 mm long (minimum) having a height of 95 mm and a depth to match the inner wall thickness. The lintel could be either precast concrete or steel.

Before proceeding with the installation of the heater, an assessment of the area immediately above the heater is required, see Fig 10. If there are no existing openings or beams within either triangle, proceed with forming the opening. However, if openings or beams occur within either triangle either:-

1. Use the guidance in the Good Building Guide 10 to assess the loads,
2. Seek specialist advice,
3. Relocate the fire position.

The 'Load Triangle'- typical inner leaf weights

122	brickwork	104 kg
122	concrete blocks	110 kg
150	concrete blocks	146.5 kg

These are well within the load capacity of proprietary lintels.

Fig 10.

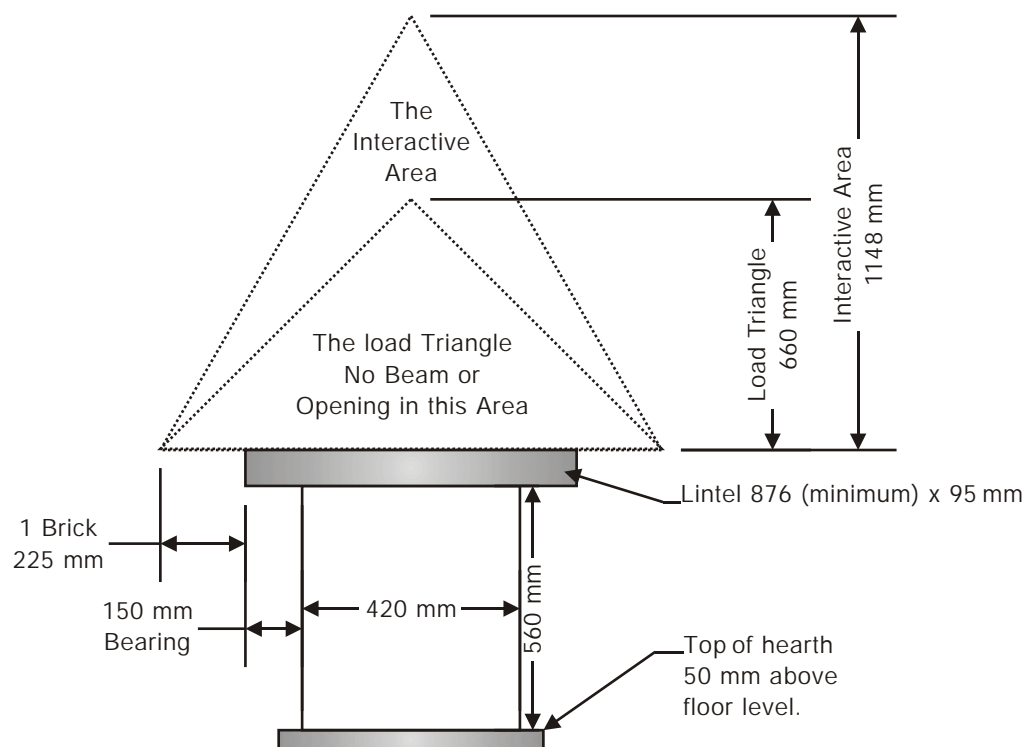

- 13.3 Mark out, where possible, centrally beneath a blockjoint where the lintel is to be fitted. Unless lime mortar has been used it will be necessary to drill four holes with a masonry drill and then use a mechanical cutter such as a 'SHARK' saw to cut out the correct size of slot required for the chosen lintel (see Fig 11.).

Fig 11.

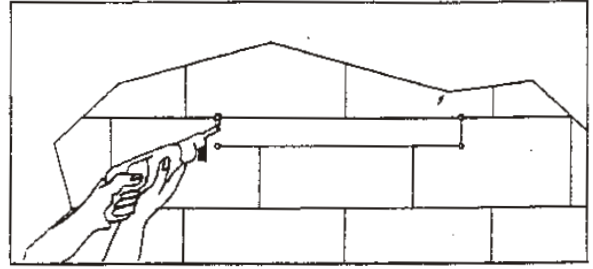

- 13.4 Fit the lintel and slate pin, leaving the wall above safe and firm. Always bed the lintel on mortar, never on a dry bed (see Fig 12.).

Fig 12.

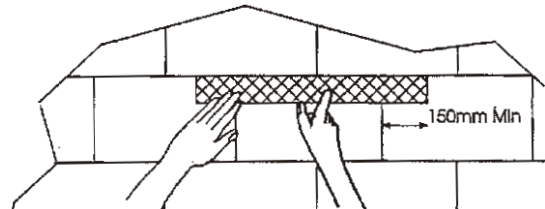

- 13.5 Remove the masonry below the lintel and clear all the debris from the cavity. Construct the opening to the size specified in Section 7.0 Non-Combustible Wall Installation (see Fig 4.).
A Rockwool™ (or similar seal such as Superlux™ type board) must be used to prevent the cavity insulation coming into contact with the hot surfaces of the heater (see Fig 2.).
Note: the cavity itself must not be bridged by any other part of the fire other than the flue duct, however the firebox may encroach into the cavity by up to 40mm.
In all installations ensure that there is no structural damage to the property or to the dampcourse.

Fig 13.

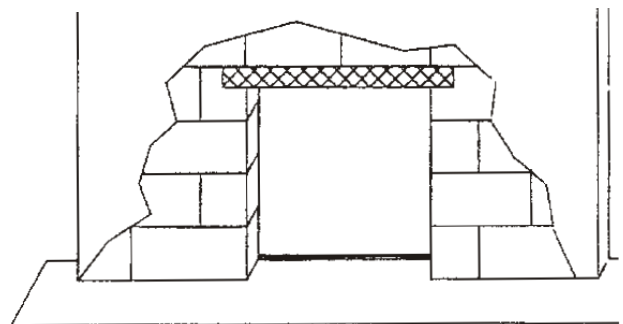

14.0 SERVICING

Important Notes:

The appliance area must be kept clear and free from combustible materials, flammable vapour and liquids.

The flow of combustion and ventilation air must not be obstructed.

Servicing the heater is recommended once a year. Servicing consists of removing dust (see RCF note on page 2) from the heater generally, cleaning the burner, examination of the flueing system, checking for gas soundness, and checking the operation of the heater.

Turn off the gas supply before commencing any servicing. Always test for gas soundness after servicing or exchanging any component, with the gas supply restored.

Only use official Robinson Willey spare parts.

14.1 Removing Outer Decorative Trim

Pull lower sides off magnets and lift to unhook from top of heater. Place to one side. Refit after work is complete.

14.2 Removing The Main Burner

Remove the glass door, and coals (if burner is to be removed). Refer to User instructions.

Remove the fender mask as shown below.

Close off gas supply at isolating elbow and disconnect from supply.

Remove the pipe clamp screw, and clamp, shown below.

The eight bottom panel fixing screws can now be removed in order to remove the complete burner assembly from the heater. Take care not to damage the gasket - it is advisable to have a spare available.

Remove the upper two fixing screws and the stabiliser screw as shown below. If the burner is being replaced the stabilising bracket/pilot shield will have to be transferred to the new burner.

Remove the control bracket fixing screw after removal of control knob (see diagram on next page).

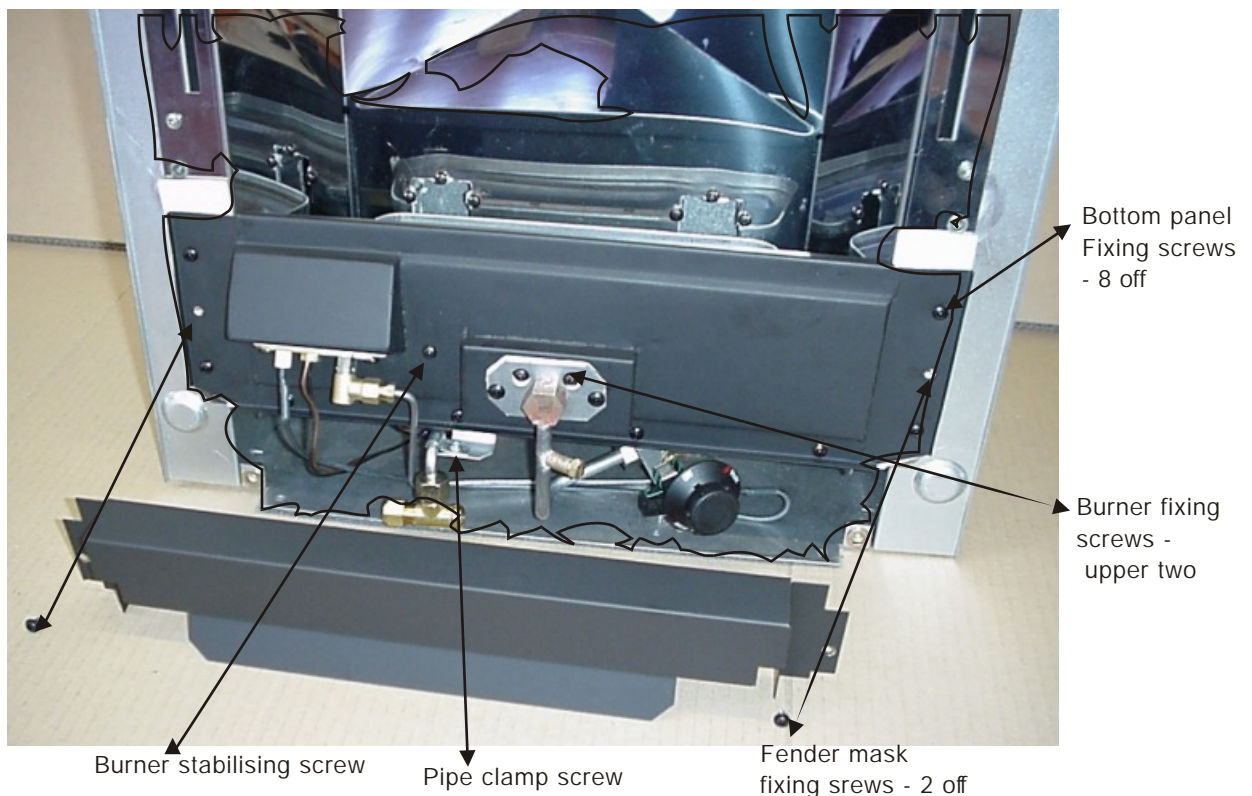

Fig 14

14.3 Removing The Control

Proceed as 14.2 above to remove the burner assembly.

Disconnect the thermocouple at the control, and undo the three gas pipes, inlet, outlet and pilot supply.

Remove the control bracket fixing screw.

The control is now free to replace, in reverse order.

14.4 Removing The Pilot Burner

Proceed as 14.2 above to remove the burner assembly.

Disconnect the gas connection at the pilot as shown below, and disconnect the thermocouple connection at the control.

Remove the two pilot mounting screws as shown below, and remove the pilot taking care not to damage the gasket. It is recommended to have a spare gasket available.

Refit in reverse order.

14.4 Removing The Injector

Remove the control bracket fixing screw after removal of control knob, then remove the inlet pipe clamp and disconnect the pipe connection at the pilot (see diagram below).

Remove the injector mounting bracket screws and ease the injector holder/mounting plate away from the heater, taking care not to damage the gasket. It is recommended to have a spare gasket available.

Access to the injector is now available.

After cleaning or replacement of the injector, refit in reverse order.

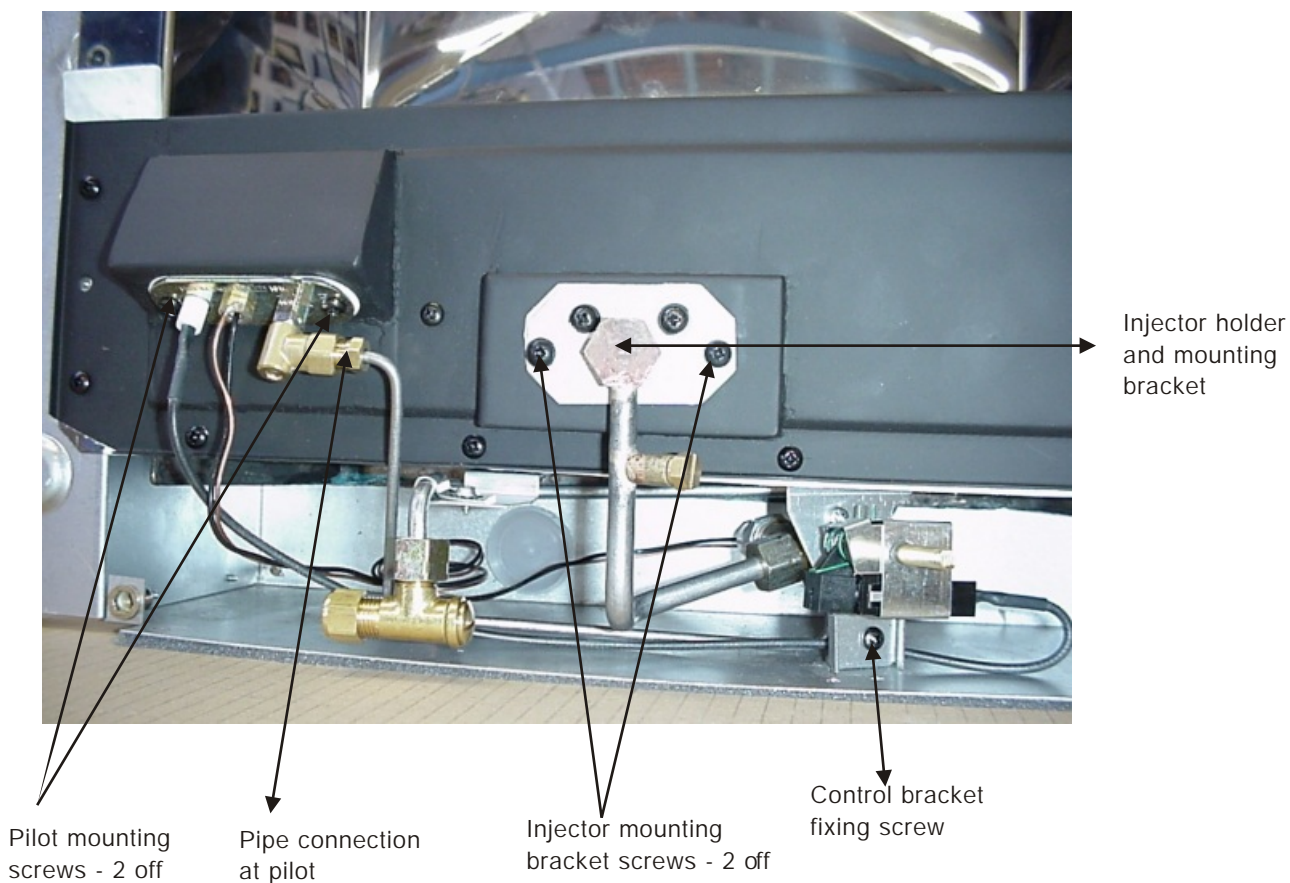

Fig 15

14.10 Pressure Relief Panels

If dealing with a complaint resulting from a delayed ignition problem it is necessary to ensure that the pressure relief panels, in the firebox top, are properly located and that the gaskets are undamaged. If the gaskets are faulty change them as detailed below:-

- (a) Lift each pressure relief panel in turn and remove the old gaskets.
- (b) Fit the new gaskets ensuring that they are properly located over the upturned flanges.
- (c) Lower the pressure relief panels onto the gaskets ensuring that they seat properly.

15.0 SPARES AND SERVICE

For spares and service apply to your local supplier or installer stating the model number and finish. This information and the serial number of the heater is shown on the small label on the left hand side of the base of the heater.

Advantage should be taken of regular servicing/inspection by a CORGI registered service agent to ensure continued safe and efficient operation of the heater.

16.0 SHORT LIST OF PARTS

RW PART NUMBER	DESCRIPTION
989254	Pack - Coals
992220	Control Knob
822328	Magnet (Decorative Trim Fixing)
822367	Pilot Burner Assembly (c/w thermocouple & electrode)
822189/A	Control / FSD
822368	Injector (Bray Cat 16/250)
989225	Glass Door Assembly
993132	Ignition Lead

All these spares plus a comprehensive list are available by contacting the address below.

989245 Issue 2

ROBINSON WILLEY LIMITED
Mill Lane, Old Swan, Liverpool. L13 4AJ. England.
Telephone: 0151-228-9111 Fax: 0151-228-6661
Website: www.robinson-willey.com Email: info@robinson-willey.com