

PERFORMANCE

Output to heating, or hot water

Combi 70 MkII 50-70,000 Btu/h (15-20kW)

Combi 90 MkII &

Outdoor Combi 90 MkII 70-90,000 Btu/h (20-26kW)

GENERAL

Burner Riello RDB

Set for kerosine Class C2

Electricity supply 230V 50Hz

Fused at 5 Amp

Flue size (conventional) 100mm (4" dia

Water content

Combi 70 MkII 80 litres (17.6gals)

Combi 90 MkII 40 litres (8.8gals)

Weight (dry)

Combi 70 MkII 158kg (348lbs)

Combi 90 MkII 158kg (348lbs)

Max hearth temp Less than 50°C

PIPE CONNECTION SIZES

Heating return 1" BSP female

Heating flow 22mm dia copper pipe

Cold water inlet 15mm dia copper pipe

Hot water outlet 15mm dia copper pipe

Pressure relief

valve discharge 15mm dia copper pipe

SEALED HEATING SYSTEM

Boiler thermostat range 75 to 85°C

Limit thermostat temp 111°C

Max operating pressure 2.5 bar

Max system pressure (cold) 1.5 bar

Min system pressure (cold) 0.5 bar

Expansion vessel capacity 12 litres

EASY TO SERVICE AND MAINTAIN

Grant Combi boilers are easy to maintain, with the Combi 90 MkII only requiring front access for routine servicing, reducing servicing time.

Both boilers incorporate Riello RDB pressure jet burners set to the stated output, for use on standard grade kerosine - Class C2. The burners can be reset on installation to operate on Class D gas oil, but only for conventional flue applications.

In accordance with our policy of continual improvement, we reserve the right to amend specifications without prior notice. Manufactured under I.S. EN ISO 9001.

Approved to OFS A100 (EN303 part 4). Complies with the EC Low Voltage and Electromagnetic Compatibility and Boiler Efficiency Directives.

® Euroflame & Multi Pass are Registered Trade Marks of Grant Engineering Limited.

SEDBUK stands for 'Seasonal Efficiency of Domestic Boilers in the UK'. *Combi's are capped at 82.9% and 82.5% Gross.

DOMESTIC HOT WATER

Flowrate

Combi 70 MkII Domestic hot water fitted & Combi 90 MkII with restrictor set at 17 litres per minute.

(flow rate is dependant on mains pressure available)

Typical hot water performance

@ 15 litres per minute

Combi 70 MkII 33 gals (150 litres) at an average temperature of 45°C.

Combi 90 MkII & Outdoor Combi 90 MkII

33 gals (150 litres) at an average temperature of 48°C.

Recovery

Typical recovery times between hot water draw offs (in hot water mode)

Combi 70 MkII: 8 minutes approx

Combi 90 MkII: 4 minutes approx

Mains water pressure

Minimum 1.5 bar (22 psi)

Maximum 10 bar (145 psi)

INSTALLATION

Installation must comply with the current British Standards and Building Regulations. Comprehensive technical information can be found in the installation manual which is supplied with every boiler.

GUARANTEES

The unique boiler heat exchangers of Grant Combi's are covered by a 5-year guarantee. All other component parts of the boiler are guaranteed for 2 years from the date of purchase, subject to being installed in accordance with the manufacturers instructions. There is also an optional 3-year extended warranty scheme available. On completion of the installation all Grant Combi boilers should be commissioned and the guarantee registration form returned to Grant UK.

AFTER SALES SERVICE

For peace of mind, all Grant boilers are backed by a national network of independent service engineers. In the unlikely event of a problem occurring, your installer should telephone our Customer Service Department on 0870 7775553.

The Combi 70MkII & Combi 90MkII dimensions

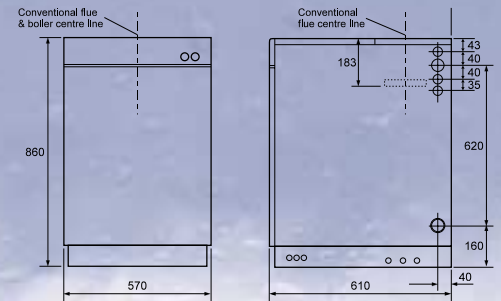

The Outdoor Combi 90MkII dimensions

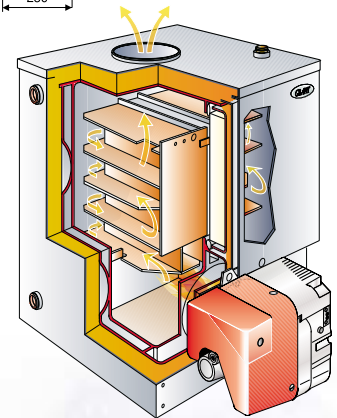
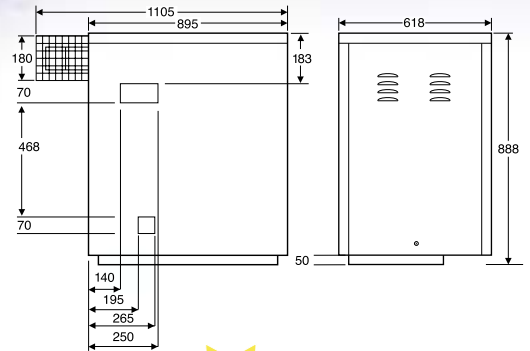

COMBI 90 MkII HEAT EXCHANGER

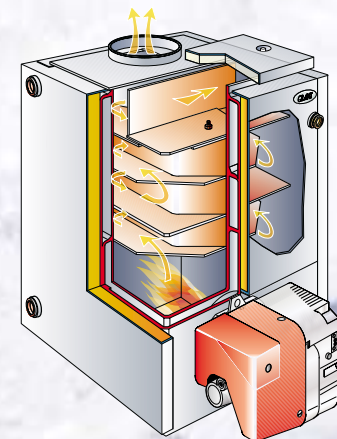

COMBI 70 MkII HEAT EXCHANGER



COMBI RANGE

Combi 70 MKII

Combi 90 MKII

Outdoor Module Combi 90 MKII

**EXCEPTIONALLY HIGH
PERFORMANCE - PRIMARY STORE
COMBI'S FOR SMALL TO MEDIUM
SIZED HOMES**



- High efficiency (93% - 95% nett) SEDBUK 'C' 82.5 - 82.9% Gross*
- Whisper quiet in operation
- Three models available: Combi 70 MkII, Combi 90 MkII and Outdoor Module Combi 90 MkII
- Front access for ease of servicing (Combi 90 only)
- Reversible hinged front door
- Models include all components for sealed heating system
- Mains pressure hot water on demand
- High domestic hot water flow rates
- Rapid recovery of heat store after hot water operation
- Now available with the new low level, high level and vertical EZ-FIT flue System
- Fully approved to OFTEC Standards and complies with EC Directives



OFCERT
Licence No's.
0202089701
0202089702
0202029607
0202089703



GRANT UK
OIL FIRED BOILERS

INSTANT HOT WATER AT MAINS PRESSURE

A Grant Combi boiler provides both central heating and hot water at mains pressure. Factory set to 70,000 Btu/h (Euroflame Combi 70 MkII) and 90,000 Btu/h (Multi Pass Combi 90 MkII), they are designed for use on a sealed heating system, with all the necessary components housed within the compact and elegant white casing.

Using the primary water stored in the boiler, for rapid response to a demand for hot water, and with quick recovery after hot water operation, the Grant Combi can provide ample amounts of hot water instantly, whenever required, night and day. A factory-set thermostatic blending valve ensures a stable control of the hot water temperature, minimising fluctuations caused by other taps being turned on!

Grant Combi boilers are designed to be installed beneath standard height kitchen worktops. The Combi 90 MkII only requires access from the front for routine servicing, whereas the Combi 70 MkII needs a removable section of worktop for service access and maintenance operations.

All pipe connections are at the rear of the boiler, passing to either left or right depending on the type of flue system used. The Combi 70 MkII is based on the Euroflame 50/70 and the Combi 90 MkII based on the Multi Pass 70/90, both comply with the OFTEC Standard OFS A100 (EN303 Part 4), and are the ideal choice for the replacement of old appliances, leading the way in the energy efficient provision of central heating and hot water in small to medium sized homes.



UNIQUE OUTDOOR MODULE COMBI

For properties where siting a combination boiler is difficult, Grant have developed a unique outdoor version of the popular Combi 90 MkII, details of which are available on a separate outdoor module brochure from Grant (UK).

GREATER EFFICIENCY

Both the Grant Multi Pass and Euroflame Combi boilers meet the requirements of the new European Boiler Efficiency Regulations with a highly efficient heat exchange operation, achieving around 93-95% nett thermal efficiency on heating.

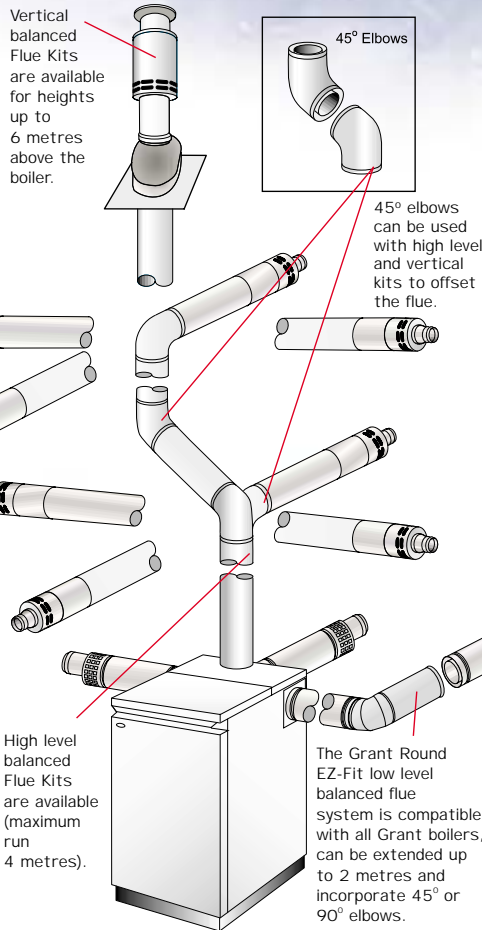

Their advanced heat exchanger design forces the hot gases through the patented baffle system for a distance of up to 8.5 feet (2.6 metres) on the Combi 70 MkII and 22 feet (6.8 metres) on the Combi 90 MkII, holding them in contact with the boiler surface area for longer. This process vastly increases the amount of heat transferred to the water jacket, enabling the boiler to operate continually at much higher efficiencies.

EZ-FIT FLUE

Grant Combi's are designed to be used with a 100mm [4"] diameter conventional flue, however, they can also be installed with Grant's new 'EZ-FIT' multi-directional low level balanced flue kits, which with the new self-sealing ducts, vastly cut down on installation time. The new kit incorporates an extremely small stainless steel terminal guard, is designed to be less obtrusive and can be installed using a core drill. High level and vertical EZ-Fit balanced flue kits and optional 45° and 90° elbows are also available. Balanced flue boilers differ from conventional flue appliances in that air for combustion is drawn from outside, via the balanced flue terminal, rather than from the internal space. The use of a balanced flue kit enables installation through any suitable outside wall, providing greater flexibility when



siting the boiler. For full details of all flue options please consult Grant's latest Retail Price List or ask for our comprehensive flue guide.

THE ADDED BENEFITS OF GRANT BALANCED FLUE BOILERS

At Grant, we have developed an external balanced flue terminal that overcomes the adverse effects of strong winds. Another important feature is a sealed burner, making Grant balanced flue boilers exceptionally quiet in the kitchen environment.

ENJOYING THE TWIN BENEFITS

An oil combination boiler provides the benefits of highly efficient oil central heating, combined with instant hot water.

The savings are considerable -- in cost and space. You save space because unlike a conventional system there is no need for a hot water cylinder in the airing cupboard, or cold water header tank in the loft (not forgetting all the extra pipework!). So you save money as there is no need to pay to store hot water.

Furthermore, you will never have to wait for a 30-gallon cylinder to heat up because you've run out of hot water! You can have bath after bath, time after time. And, of course, because a combi provides hot water direct from the cold mains, you'll enjoy powerful, invigorating showers.

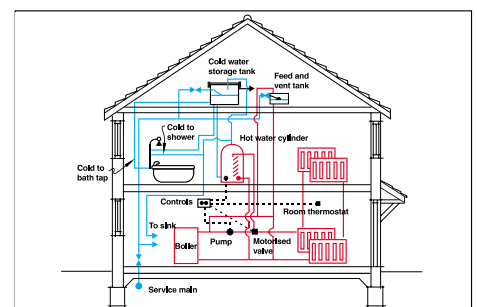

TRADITIONAL SYSTEM

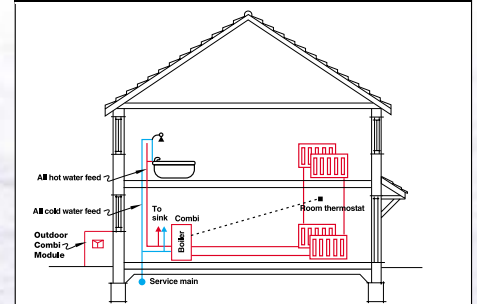

GRANT COMBI SYSTEM

Combi 70 MkII

[with new pipework cover removed]

- 1 System pressure gauge
- 2 Blending valve
- 3 Boiler thermostat & overheat thermostat
- 4 Primary store thermostat
- 5 Grundfoss 15-60 circulating pump
- 6 Pump isolating valve
- 7 Flow switch
- 8 Domestic hot water heat exchanger
- 9 Mains cold water supply valve
- 10 Filling loop isolating valve
- 11 Primary return isolating valve
- 12 Riello RDB Burner
- 13 Flexible filling loop
- 14 Boiler drain cock
- 15 Expansion vessel



Remote Timer Kit
(optional)



Plug-in timers
(optional)

Combi 90 MkII

[with new pipework cover removed]

- 1 System pressure gauge
- 2 Blending valve
- 3 Boiler thermostat & overheat thermostat
- 4 Primary store thermostat
- 5 Grundfoss 15-60 circulating pump
- 6 Pump isolating valve
- 7 Flow switch
- 8 Domestic hot water heat exchanger
- 9 Mains cold water supply valve
- 10 Filling loop isolating valve
- 11 Primary return isolating valve
- 12 Riello RDB Burner
- 13 Flexible filling loop
- 14 Boiler drain cock
- 15 Expansion vessel

