

INSTALLER INSTRUCTIONS

CONTENTS

1	DESCRIPTION OF THE BOILER	pag.	94
2	INSTALLATION	pag.	98
3	CHARACTERISTICS	pag.	108
4	USE AND MAINTENANCE	pag.	111

IMPORTANT

When carrying out commissioning of the boiler, you are highly recommended to perform the following checks:

- Make sure that there are no liquids or inflammable materials in the immediate vicinity of the boiler.
- Make sure that the electrical connections have been made correctly and that the earth wire is connected to a good earthing system.
- Open the gas tap and check the soundness of the connections, including that of the burner.
- Make sure that the boiler is set for operation for the type of gas supplied.
- Check that the flue pipe for the outlet of the products of the combustion is unobstructed and has been properly installed.
- Make sure that any shutoff valves are open.
- Make sure that the system is charged with water and is thoroughly vented.
- Check that the circulating pump is not locked [CAUTION: Remember to release the pump coupled with the control panel, if necessary, to protect the electronic control card].
- Purge the system, bleeding off the air present in the gas pipe by operating the pressure relief valve on the gas valve inlet.
- Check that the syphoned drip is fully filled with water. If necessary, fill it via the special opening.

FONDERIE SIME S.p.A. of Via Garbo 27 - Legnago (VR) - Italy declares that its hot water boilers, which bear the CE mark under Gas Directive 90/396/CEE and are fitted with a safety thermostat calibrated to a maximum of 110°C, **are not subject** to application of PED Directive 97/23/CEE as they meet the requirements of article 1 paragraph 3.6 of the Directive.

1 DESCRIPTION OF THE BOILER

1.1 INTRODUCTION

“DEWY” boilers are premix condensation thermal appliances which use microprocessor technology for function control and

management. They comply with the european directives 90/396/CEE, 89/336/CEE, 73/23/CEE, 92/42/CEE and with the european specifications EN 483 - EN 625.

These appliances can be fired by natural gas (methane) and propane gas (G31). The instructions given in this manual are provided to ensure proper installation and perfect operation of the appliance.

1.2 DIMENSIONS

1.2.1 “30/80” model

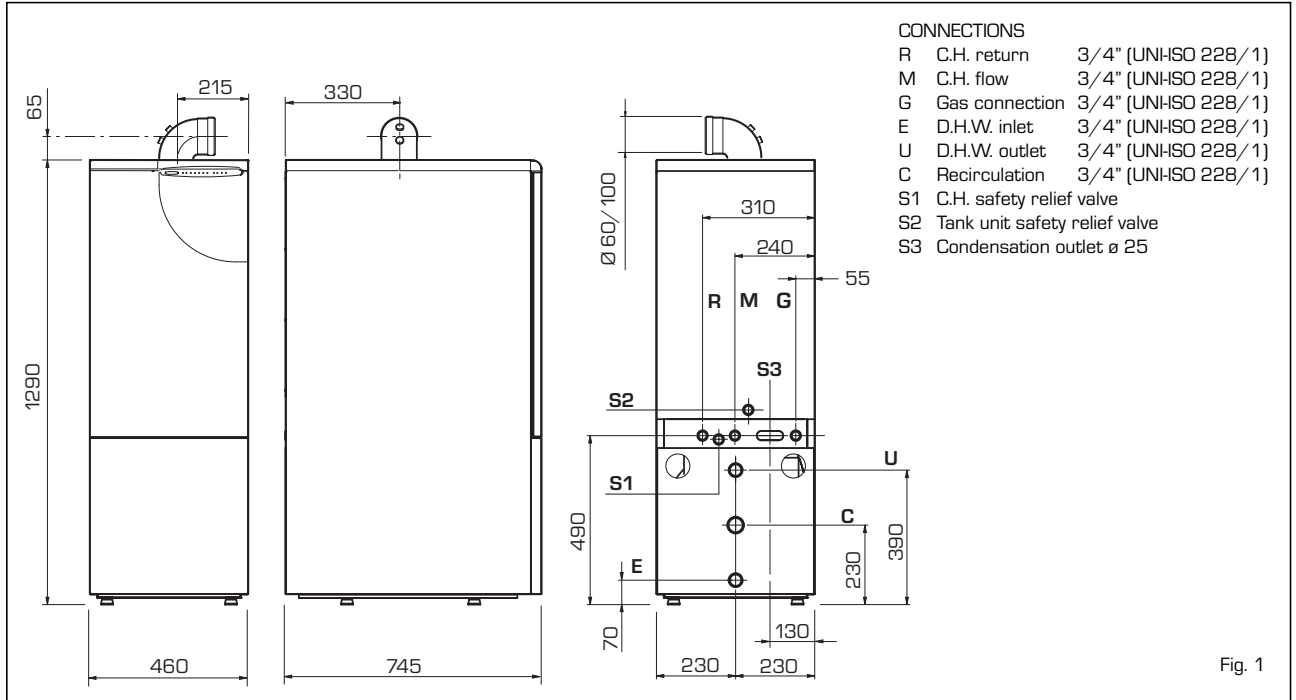

1.2.2 “30/130” model

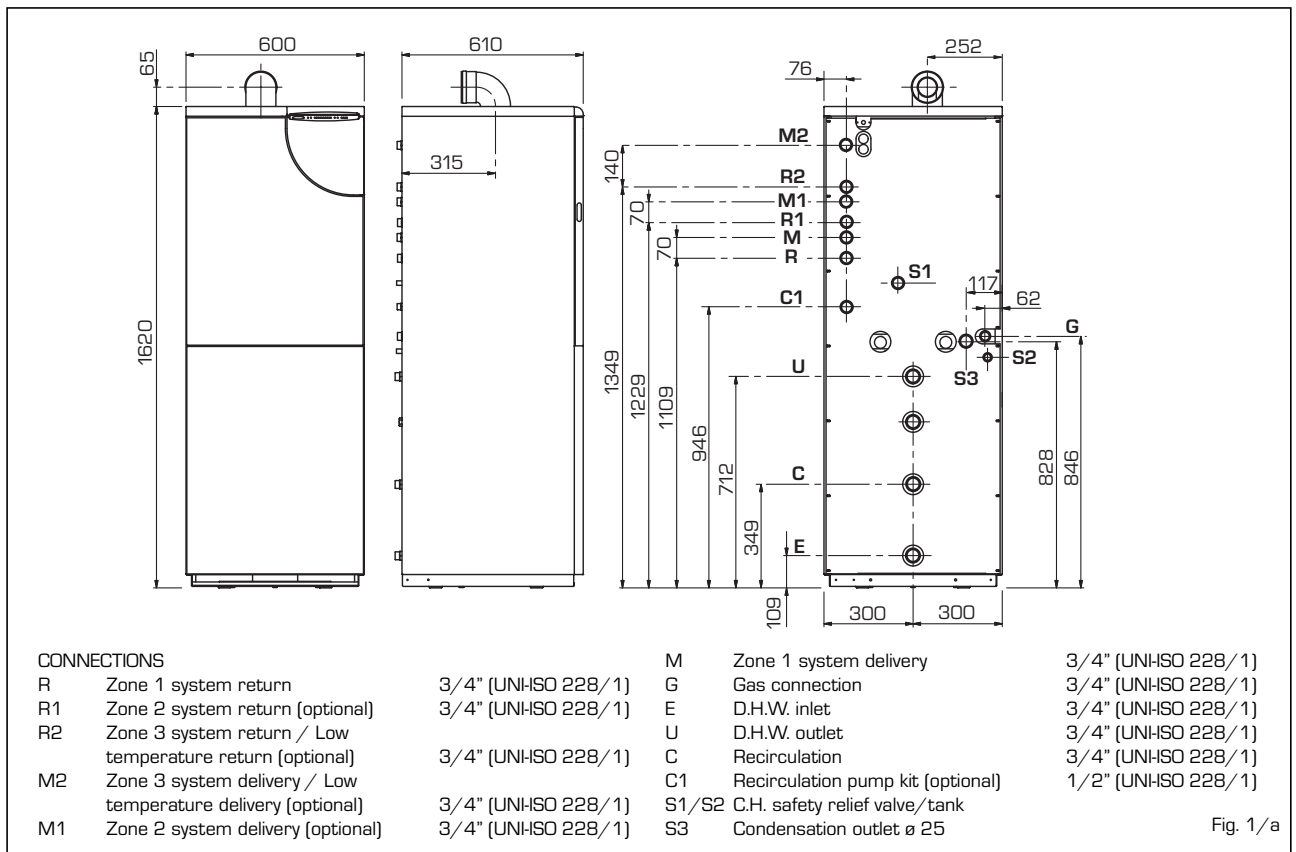

1.3 TECHNICAL FEATURES

		DEWY 30/80	DEWY 30/130
Heat output			
Nominal (80-60°C)	kW [kcal/h]	29,3 (25.200)	29,3 (25.200)
Minimum (80-60°C)	kW [kcal/h]	10,4 (9.000)	10,4 (9.000)
Nominal (50-30°C)	kW [kcal/h]	32,0 (27.600)	32,0 (27.600)
Minimum (50-30°C)	kW [kcal/h]	11,4 (9.800)	11,4 (9.800)
Nominal D.H.W. heat output	kW	29,3	29,3
Heat input			
Nominal/Minimum	kW	30,0 / 10,8	30,0 / 10,8
Efficiency (80-60°C)			
Nominal/Minimum output	%	97,7 / 96,7	97,7 / 96,7
Efficiency (50-30°C)			
Nominal/Minimum output	%	106,8 / 105,8	106,8 / 105,8
Water content	l	9,5	10,9
Adsorbed power consumption	W	175	175
Electrical protection grade		IP X4D	IP X4D
Maximum water head	bar	3	3
Maximum temperature	°C	85	85
Expansion vessel			
Capacity	l	8	10
Preloading pressure	bar	1	1
C.H. setting range	°C	20 - 80	20 - 80
D.H.W. setting range	°C	10 - 60	10 - 60
D.H.W. production			
D.H.W. flow rate (EN 625)	l/min	19,9	21,0
Continuous D.H.W. flow rate Δt 30°C	l/min	14	14
Maximum D.H.W. pressure	bar	7	7
D.H.W. tank capacity	l	80	130
D.H.W. expansion vessel	l	4	4
Recuperation time between 25 and 55°C	min	9'	9'40"
Smokes temperature			
Maximum/ Minimum (80-60°C)	°C	70 / 69	70 / 69
Maximum/ Minimum (50-30°C)	°C	48 / 45	48 / 45
Smokes flow	kg/h	49	49
Category		II2H3P	II2H3P
Type		B23, C13-33-43-53	B23, C13-33-43-53
Weight	kg	127	191
Main burner nozzles			
Quantity	n°	1	1
G20	ø mm	6,0	6,0
G25	ø mm	7,7	7,7
G31	ø mm	4,3	4,3
Gas consumption			
Nominal / Minimum (G20)	m ³ st/h	3,17 / 1,14	3,17 / 1,14
Nominal / Minimum (G25)	m ³ st/h	3,69 / 1,32	3,69 / 1,32
Nominal / Minimum (G31)	kg/h	1,22 / 0,44	1,22 / 0,44
Gas supply pressure			
G20	mbar	20	20
G25	mbar	25	25
G31 (Propan)	mbar	37	37
CO₂ % methane (G20)	min/max	9,2 / 9,3	9,2 / 9,3
CO₂ % methane (G25)	min/max	9,5 / 9,6	9,5 / 9,6
CO₂ % propan (G31)	min/max	10,1 / 10,3	10,1 / 10,3
CO emission	ppm	27	27
NO_x emission (Class 5)	ppm	35	35

(1) Flow calculated with a fixed temperature on the hot-water service potentiometer of 60°C for a maximum period of 10 minutes

1.4 FUNCTIONAL DIAGRAM

1.4.1 "30/80" model

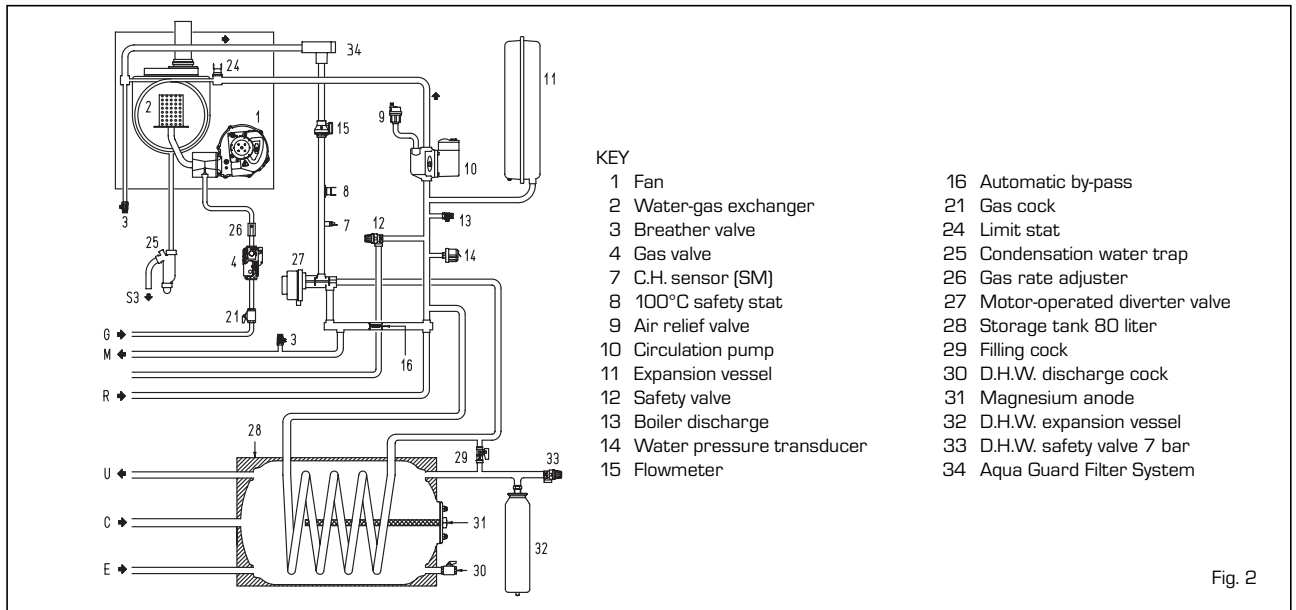

Fig. 2

1.4.2 "30/130" model

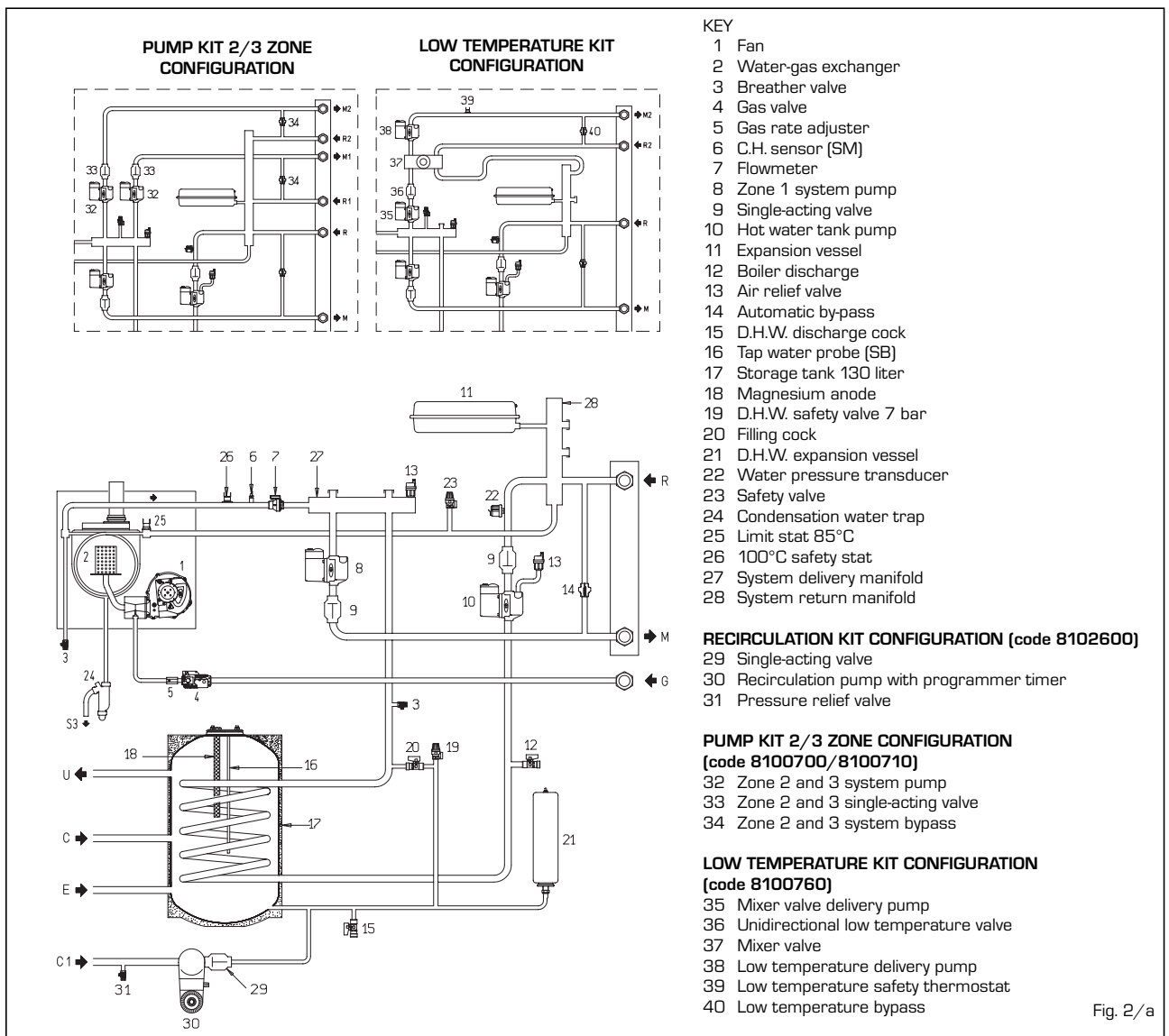
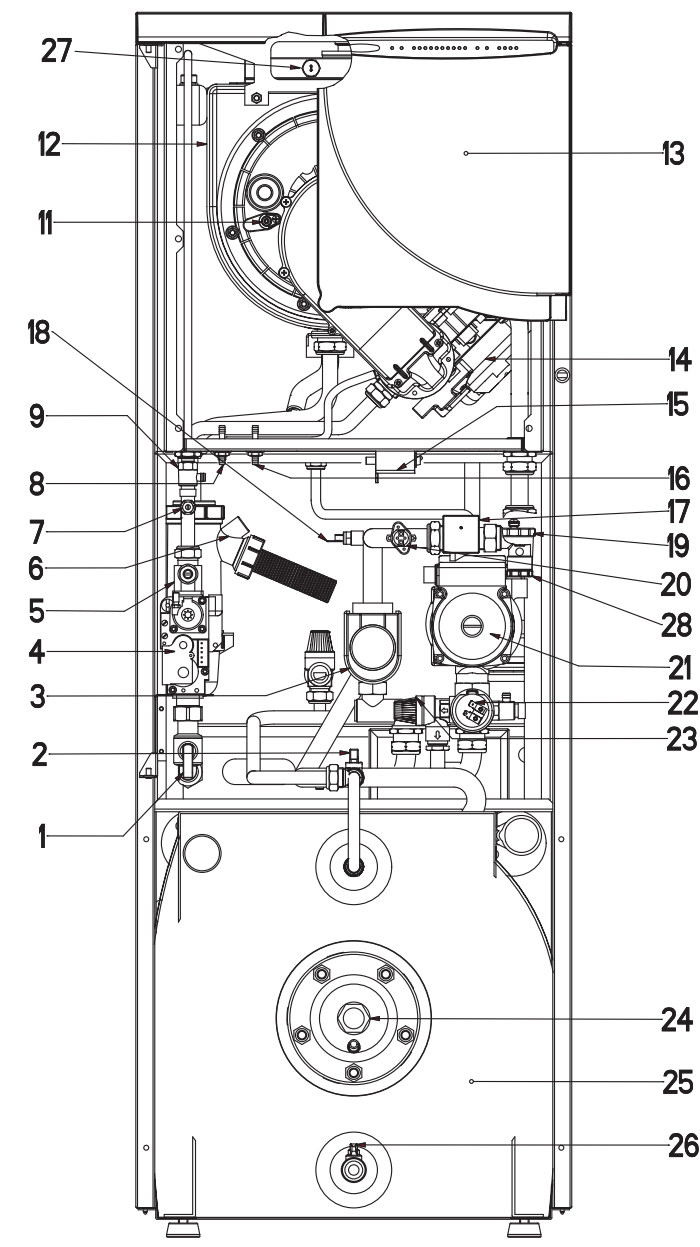

Fig. 2/a

1.5 MAIN COMPONENTS

1.5.1 "30/80" model



- | | |
|---------------------------------|-------------------------------|
| KEY | |
| 1 Gas cock | 15 Ignition transformer |
| 2 Manual filling | 16 Negative pressure take-off |
| 3 Motor-operated diverter valve | 17 Flowmeter |
| 4 Gas valve | 18 C.H. sensor (SM) |
| 5 Gas rate adjuster | 19 Automatic breather |
| 6 Condensation water trap | 20 100°C safety stat |
| 7 Gas pressure take-off | 21 Circulating pump |
| 8 Positive pressure take-off | 22 Water pressure transducer |
| 9 Breather valve | 23 Safety valve |
| 11 Sensing electrode | 24 Magnesium anode |
| 12 Water-gas exchanger | 25 Storage tank 80 liter |
| 13 Control panel | 26 D.H.W. discharge cock |
| 14 Fan | 27 Smoke stat |
| | 28 Aqua Guard Filter System |

Fig. 3

1.5.2 "30/130" model

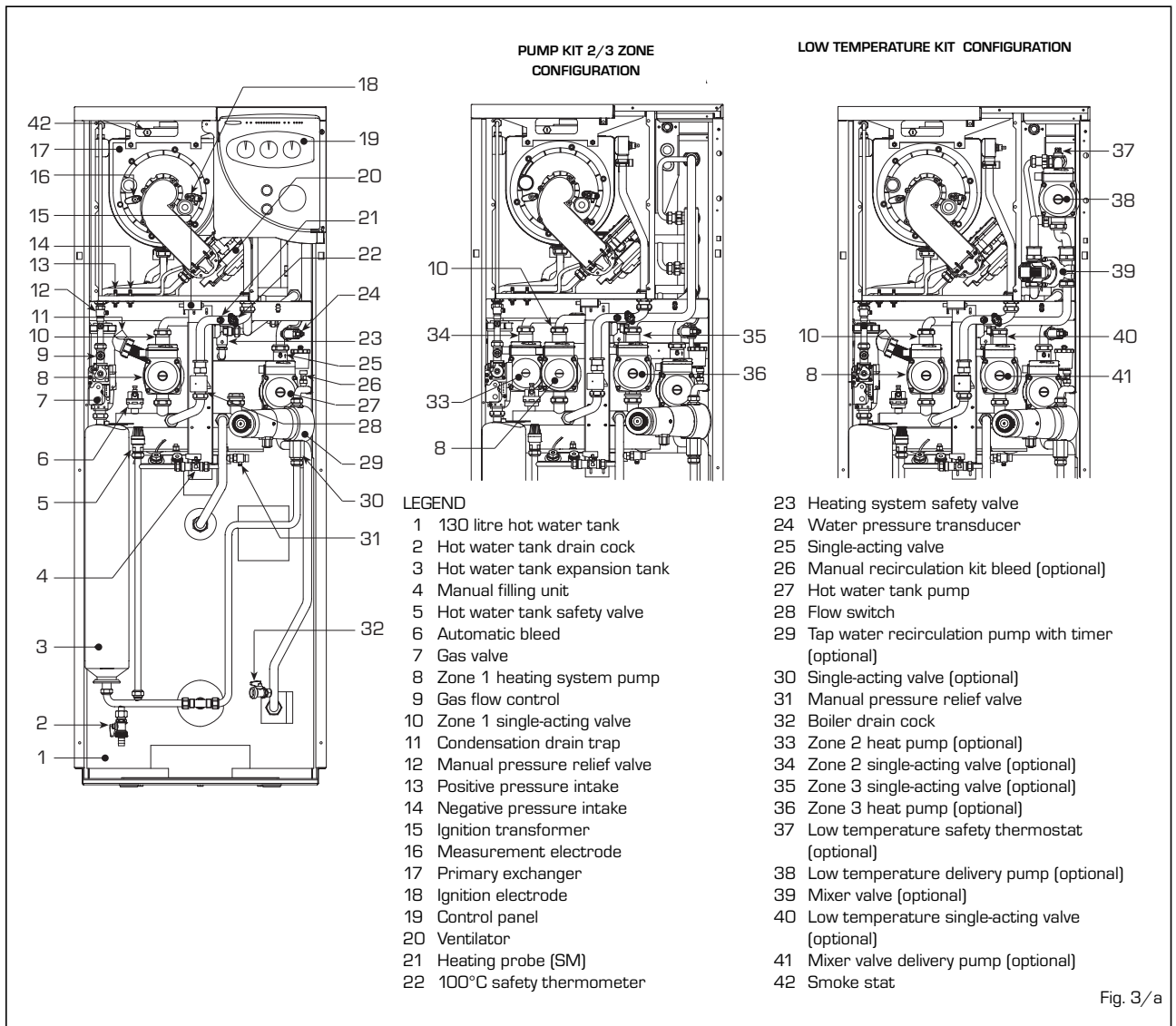

2 INSTALLATION

The boiler must be installed in a fixed location and only by specialized and qualified firms in compliance with all instructions contained in this manual. Furthermore, the installation must be in accordance with current standards and regulations.

2.1 BOILER ROOM

The "DEWY" version boilers can be installed in any domestic environment without any location restrictions or comburent air requirements.

2.2 CONNECTING UP SYSTEM

To protect the heat system from damaging corrosion, incrustation or deposits, after installation it is extremely important to clean the system using suitable products

such as, for example, Sentinel X300 or X400. Complete instructions are provided with the products but, for further information, you may directly contact GE Betz.

For long-term protection against corrosion and deposits, the use of inhibitors such as Sentinel X100 is recommended after cleaning the system. It is important to check the concentration of the inhibitor after each system modification and during maintenance following the manufacturer's instructions (specific tests are available at your dealer). The safety valve drain must be connected to a collection funnel to collect any discharge during interventions.

WARNING: Failure to clean the heat system or add an adequate inhibitor invalidates the device's warranty.

Gas connections must be made in accordance with current standards and regula-

tions. When dimensioning gas pipes from the meter to the module, both capacity volume (consumption) in m³/h and gas density must be taken into account.

The sections of the piping making up the system must be such as to guarantee a supply of gas sufficient to cover the maximum demand, limiting pressure loss between the gas meter and any apparatus being used to not greater than:

- 1.0 mbar for family II gases (natural gas);
- 2.0 mbar for family III gases (butane or propane).

A sticker inside the module includes identification and gas type data specific to the module.

2.2.1 Connection of condensation water trap

The drip board and its water trap must be

connected to a civil drain through a pipe with a slope of at least 5 mm per metre to ensure drainage of condensation water.

The plastic pipes normally used for civil drains are the only type of pipe which is appropriate for conveying condensation to the building's sewer pipes.

2.2.2 Filter on the gas pipe

The gas valve is supplied ex factory with an inlet filter, which, however, is not adequate to entrap all the impurities in the gas or in gas main pipes.

To prevent malfunctioning of the valve, or in certain cases even to cut out the safety device with which the valve is equipped, install an adequate filter on the gas pipe.

2.4 SYSTEM FILLING

Filling of the boiler and the system is done by the charge cock [2 fig. 3 - 4 fig. 3/a].

The charge pressure, with the system cold, must be **1 bar**.

Filling must be done slowly so as to allow any air bubbles to be bled off through the air valves.

Once the filling has been completed, close the filling tap.

2.5 COAXIAL DUCT ø 60/100

The air inlet-smoke outlet assembly, code 8096250, is included in the standard supply of the appliance complete with mounting instructions.

2.5.1 Coaxial duct accessories

The accessories to be used for this type of installation and some of the connecting systems that may be adopted are illustrated in fig. 4.

With the pipe bend included in the kit, the maximum length of the piping should not exceed 2.8 meter.

When the vertical extension code 8086950 is used, the terminal part of the pipe must always come out horizontally.

2.5.2 Positioning the outlet terminals

The outlet terminals for forced-draught appliances may be located in the external perimeter walls of the building.

To provide some indications of possible solutions, **Table 1** gives the minimum distances to be observed, with reference to the type of building shown in fig. 5.

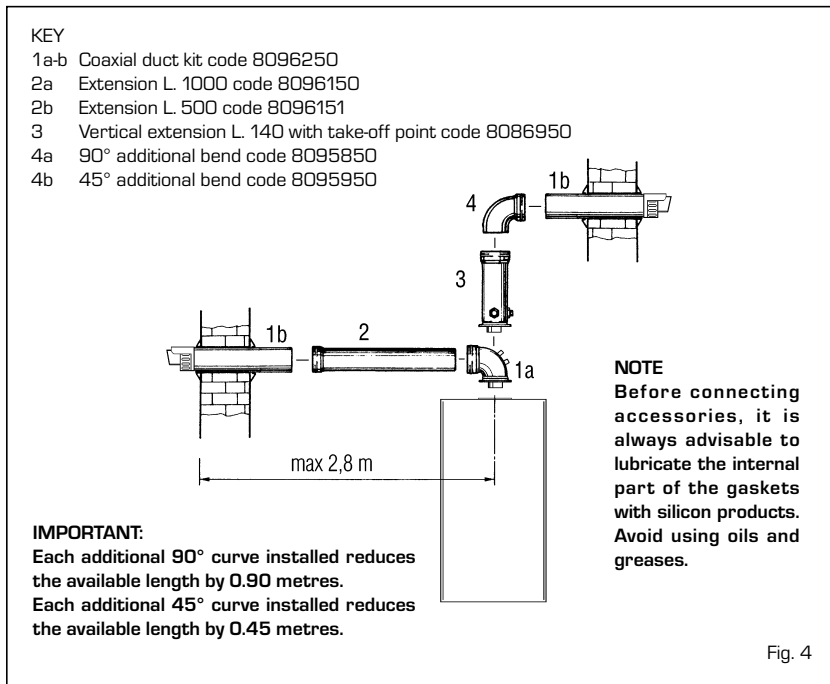

Fig. 4

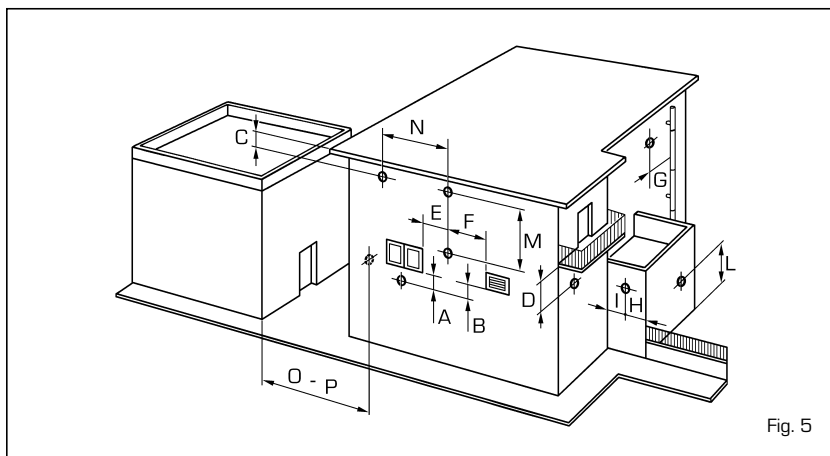

Fig. 5

TABLE 1

Siting of terminal	Appliances from 7 to 35 kW (distances in mm)
A - below openable window	600
B - below ventilation opening	600
C - below eaves	300
D - below balcony [1]	300
E - from adjacent window	400
F - from adjacent ventilation opening	600
G - from horizontal or vertical soil or drain pipes [2]	300
H - from corner of building	300
I - from recess in building	300
L - from ground level or other treadable surface	2500
M - between two terminals set vertically	1500
N - between two terminals set horizontally	1000
O - from a surface facing without openings or terminals	2000
P - as above but with openings and terminals	3000

1) Terminals below a practicable balcony must be located in such a way that the total path of the smoke from its outlet point from the terminal to its outlet point from the external perimeter of the balcony, including the height of possible railings, is not less than 2000 mm.
2) When siting terminals, where materials that may be subject to the action of the combustion products are present in the vicinity, e.g., eaves, gutters and downspouts painted or made of plastic material, projecting timberwork, etc., distances of not less than 1500 mm must be adopted, unless adequate shielding is provided to guard these materials.

2.5.3 Coaxial duct outlet on the roof

The accessories to be used for this type of installation and some of the connecting systems that may be adopted are illustrated in fig. 7.

It is possible to insert up to a maximum of three extensions and reach a maximum rectilinear distance of 3.7 meter.

Should it be necessary to make two changes of direction in the pipe development, the maximum length of the pipe must not exceed 2 meter.

2.6 SEPARATE PIPES ø 80

A special kit may be used to separate the flue gas outlet from the fresh air intake.

The intake may be installed to the right or left of the flue gas outlet.

Both ducts may be oriented in any direction. Refer to fig. 8 for positioning.

The maximum overall length of the intake and exhaust ducts depends on the head losses of the single fittings installed (excluding the doublers) and must not be greater than 15,5 mm H₂O.

For head losses in the fittings, refer to Table 2.

2.6.1 Separate pipe accessories

Kit code 8089911 is supplied for this purpose (fig. 9).

The sectored diaphragm is to be used according to the maximum head loss allowed in both pipes, as given in fig. 10.

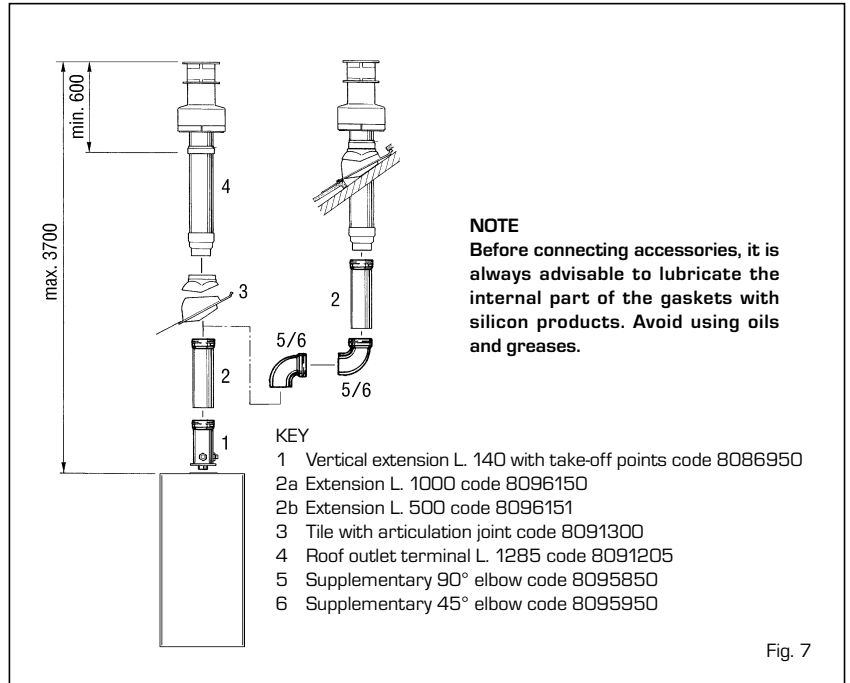

Fig. 7

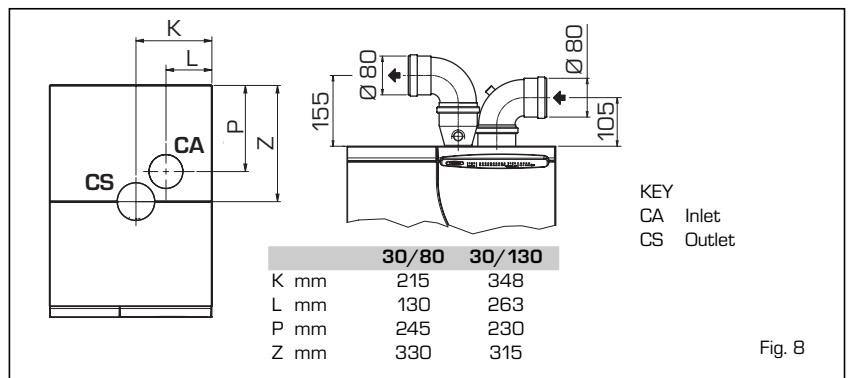

Fig. 8

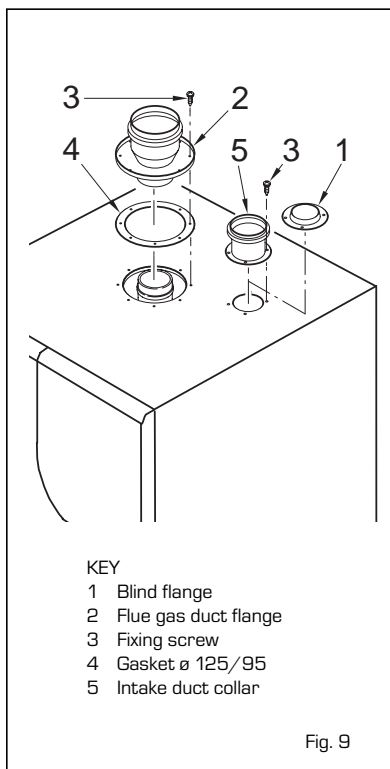

Fig. 9

TABLE 2

Accessories ø 80	Total head loss (mm H ₂ O)		
	DEWY		
	Inlet	Outlet	Roof outlet
90° elbow MF	0,30	0,50	-
45° elbow MF	0,20	0,40	-
Extension L. 1000 (horizontal)	0,20	0,40	-
Extension L. 1000 (vertical)	0,30	0,30	-
Outlet terminal	-	0,40	-
Inlet terminal	0,10	-	-
Doubler fitting	0,30	-	-
Roof outlet terminal L.1381	-	-	0,60

Example of allowable installation calculation in that the sum of the head losses of the single fittings is less than 15,5 mm H₂O:

	Inlet	Outlet	
7 m horizontal pipe ø 80 x 0,20	1,40	-	
7 m horizontal pipe ø 80 x 0,40	-	2,80	
n° 2 90° elbows ø 80 x 0,30	0,60	-	
n° 2 90° elbows ø 80 x 0,50	-	1,00	
n° 1 terminal ø 80	0,10	0,40	
Total head loss	2,10	4,20	= 6,3 mm H₂O

2.6.2 Connection with existing flues

The \varnothing 80 flue gas pipe may be connected to an existing flue. When the "DEWY" boiler is running at a low temperature, a regular flue may be used under the following conditions:

- No other boiler must be using the flue.
- The flue interior must be shielded from direct contact with condensation from the boiler.

The products of combustion must be conveyed through a flexible or rigid plastic pipe around 100 to 150 mm in diameter, and condensation must be siphoned

off at the foot of the pipe.

The usable height of the water trap must be at least 150 mm.

2.6.3 Separate-pipes roof outlet

The accessories to be used for this type of installation and some of the connecting systems that may be adopted are illustrated in fig. 12.

There is the possibility of doubling the air-intake and smoke-outlet pipes and then bringing them back together again so as to

obtain a concentric discharge by using the doubler fitting (9 fig. 12).

In these cases, when assembling, recover the silicone gasket used on the terminal adapter (5 fig. 11), which is to be replaced by the doubler; and insert it into the seat made in the doubler.

For this type of discharge the sum of the maximum rectilinear development allowed for the pipes must not exceed 15,5 mm H₂O.

When calculating the lengths of pipe, take into account the parameters given in **Table 2.**

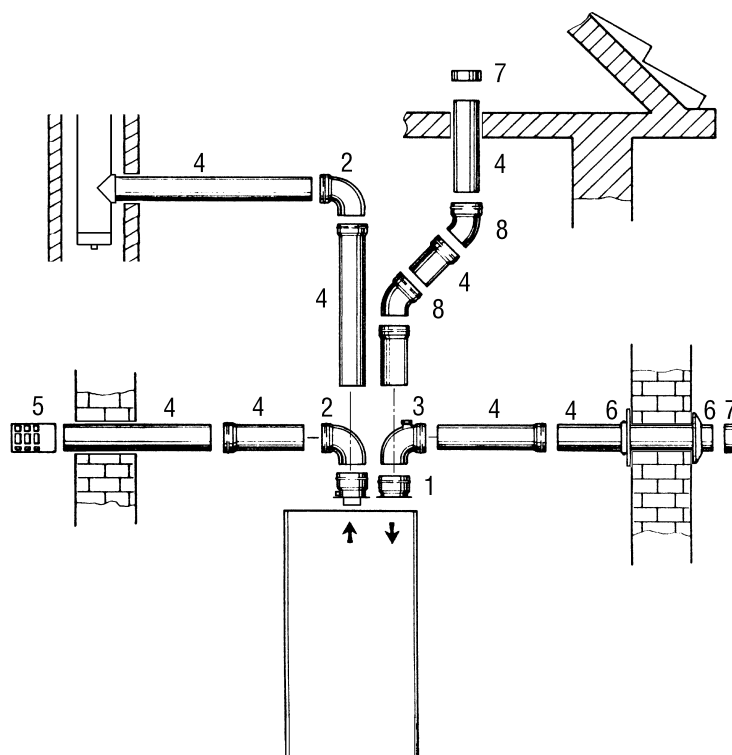

KEY

- 1 Separate pipes kit code 8089911
- 2 90° elbow MF code 8077450 (6 pz.)
- 3 90° elbow MF with take-off points code 8077452
- 4a Extension L. 1000 code 8077351 (6 pz.)
- 4b Extension L. 500 code 8077350 (6 pz.)
- 5 Outlet terminal code 8089501
- 6 Int.-est. ring kit code 8091500
- 7 Inlet terminal code 8089500
- 8 45° elbow MF code 8077451 (6 pz.)

NOTE

Before connecting accessories, it is always advisable to lubricate the internal part of the gaskets with silicon products. Avoid using oils and greases.

Fig. 10

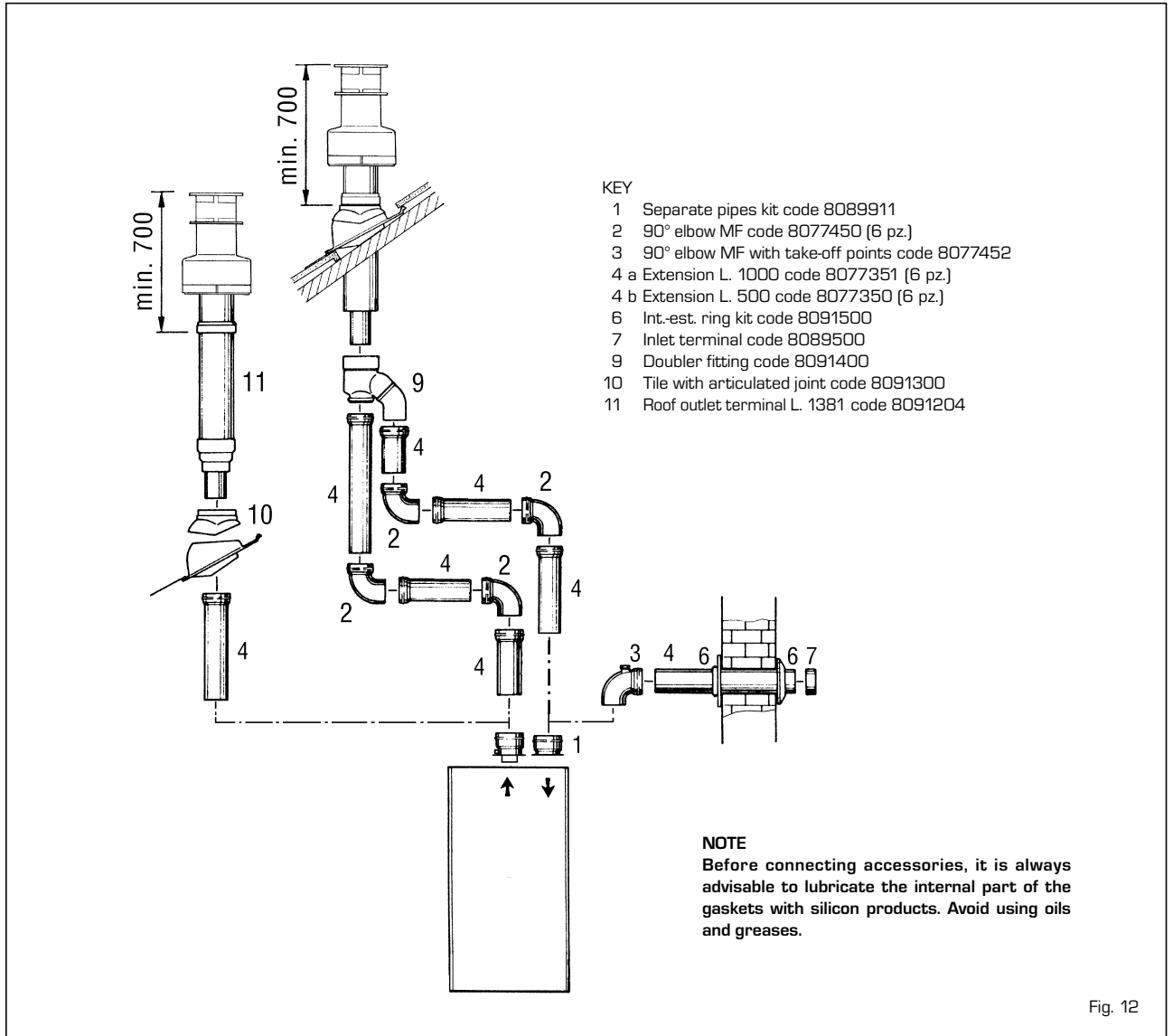

Fig. 12

2.8 ELECTRICAL CONNECTION

The boiler is supplied with an electric cable. Should this require replacement, it must be purchased exclusively from SIME. The electric power supply to the boiler must be 230V - 50Hz single-phase through a fused main switch, with at least 3 mm spacing between contacts. Respect the L and N polarities and the earth connection.

NOTE: Device must be connected to an efficient earthing system. SIME declines all responsibility for injury or damage to persons, animals or things, resulting from the failure to provide for proper earthing of the appliance. Always turn off the power supply before doing any work on the electrical panel.

2.8.1 Room stat connection (fig. 13 pos. A)

To gain access to the electronic board connector (3), remove the control panel cover

and connect the room stat to the terminals TA (5-6) after having removed the jumper. The thermostat or timer-thermostat, recommended for better room temperature control, must be class II as specified by standard EN 60730.1 (clean contact).

WARNING: Applying mains voltage to the terminals of connector (3) will irreparably damage the control board. Make sure that any connections to be made are not carrying mains voltage.

2.8.2 "Logica Remote Control" connection (fig. 13 pos. B)

The electrical plant must comply with local standards and all cables must comply with low safety voltage requirements of EN 60730. For lengths up to 25 m, use cables of section 0.25 mm², for longer lengths up to 50 m use cables of section 0.5 mm². First of all, assemble and wire the socket (2), then insert the equipment which will start-up as soon as it receives current.

To gain access to connector (3) remove the control panel cover and connect the climate regulator to terminals CR (6-7).

WARNING: External voltage must not be connected to terminals 1-2-3-4 of the "Logica Remote Control". A telephone remote switch with a zero potential contact or a window contact can be connected to terminals 3-4. Equipment for the checking of civil plants via a telephone line includes the model TEL 30.4 LANDIS & STAIEFA.

2.8.3 External temperature sensor connection (fig. 13 pos. C)

The cables must comply with low safety voltage requirements of EN 60730. For lengths up to 25 m, use cables of section 0.25 mm², for longer lengths up to 50 m use cables of section 0.5 mm². To gain access to boiler connector (3) remove the control panel cover and connect the external temperature sensor to terminals SE (8-9).

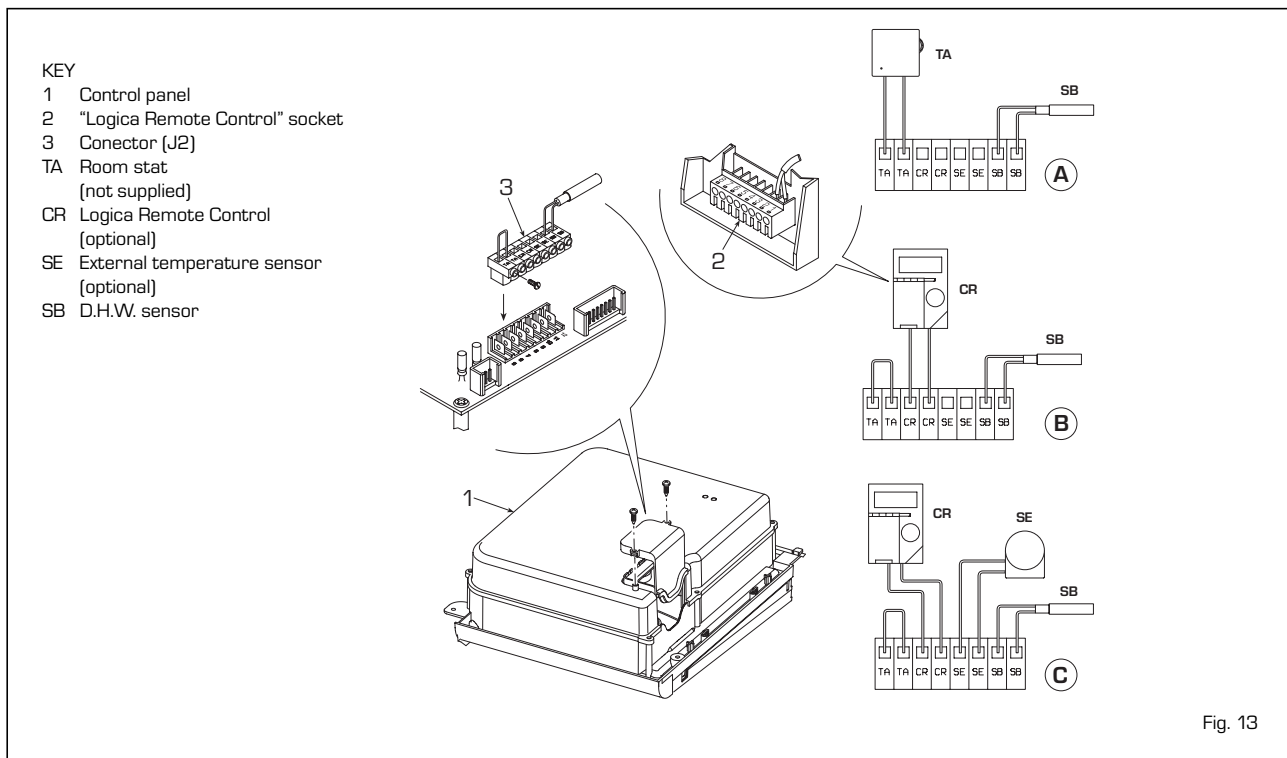

Fig. 13

2.8.4 Wiring diagram "30/80" model

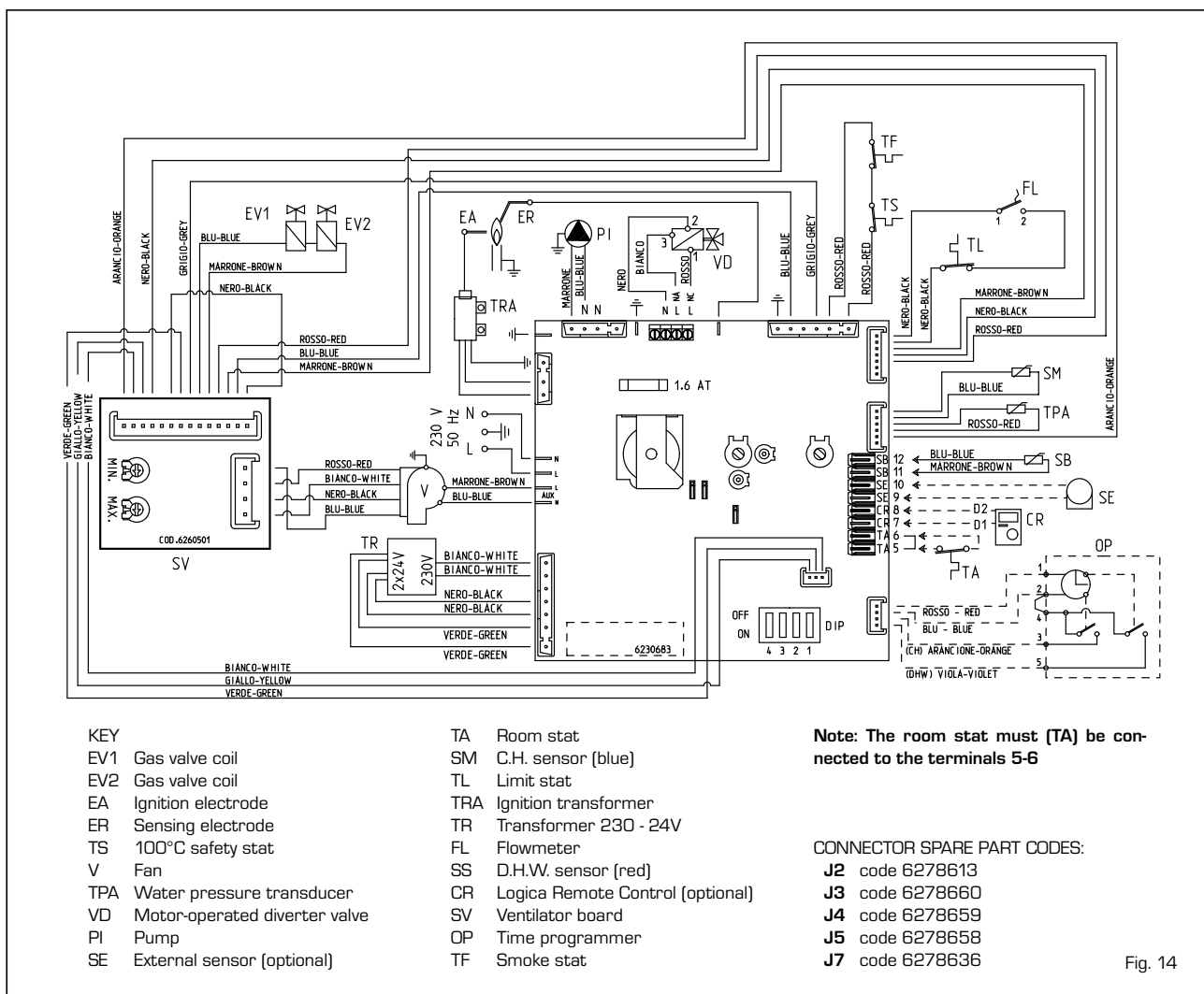

Fig. 14

2.8.5 Wiring diagram "30/130" model

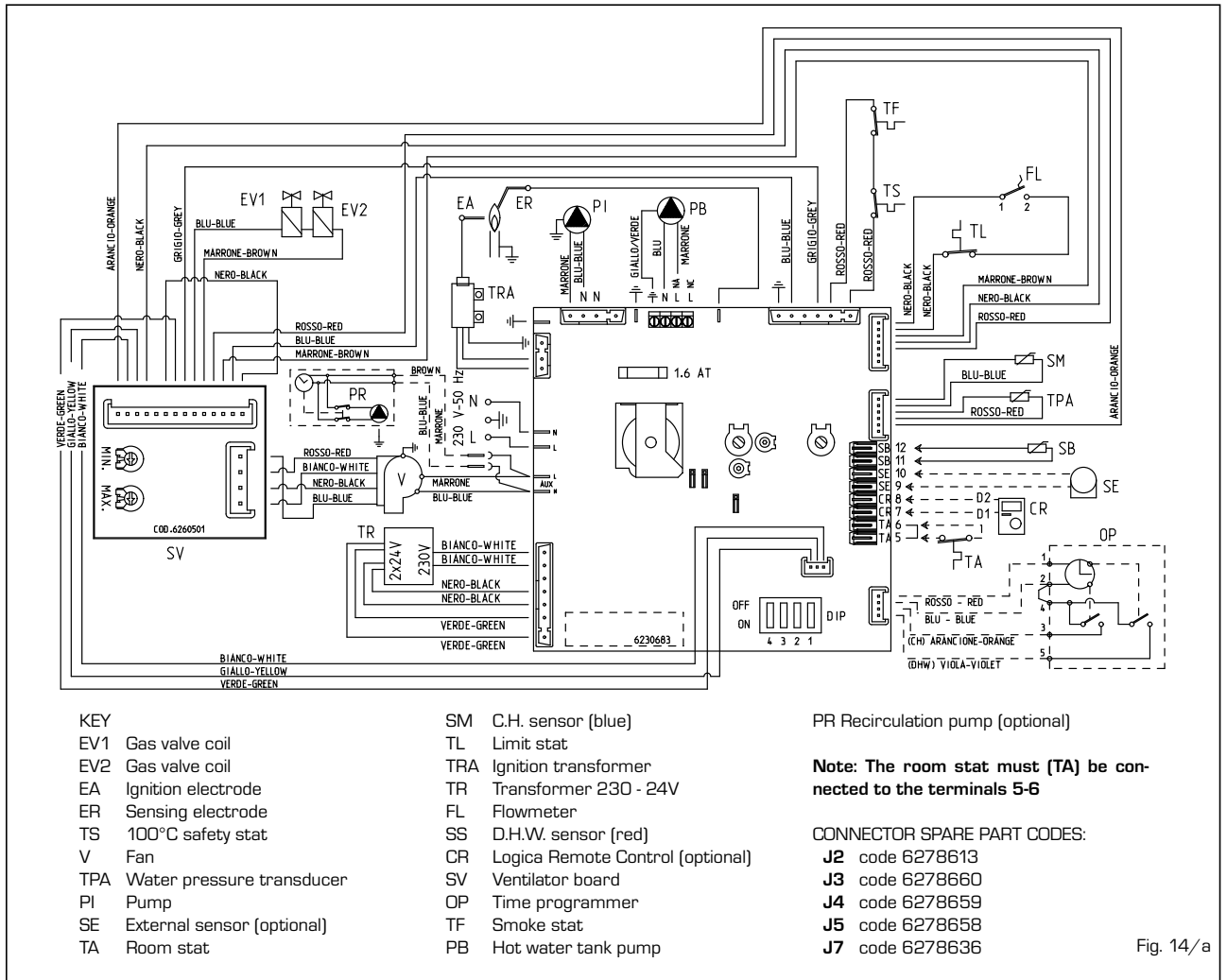

Fig. 14/a

2.8.6 "30/130" wiring diagram with zone pump kit (code 8100700) and third zone pump kit (8100710)

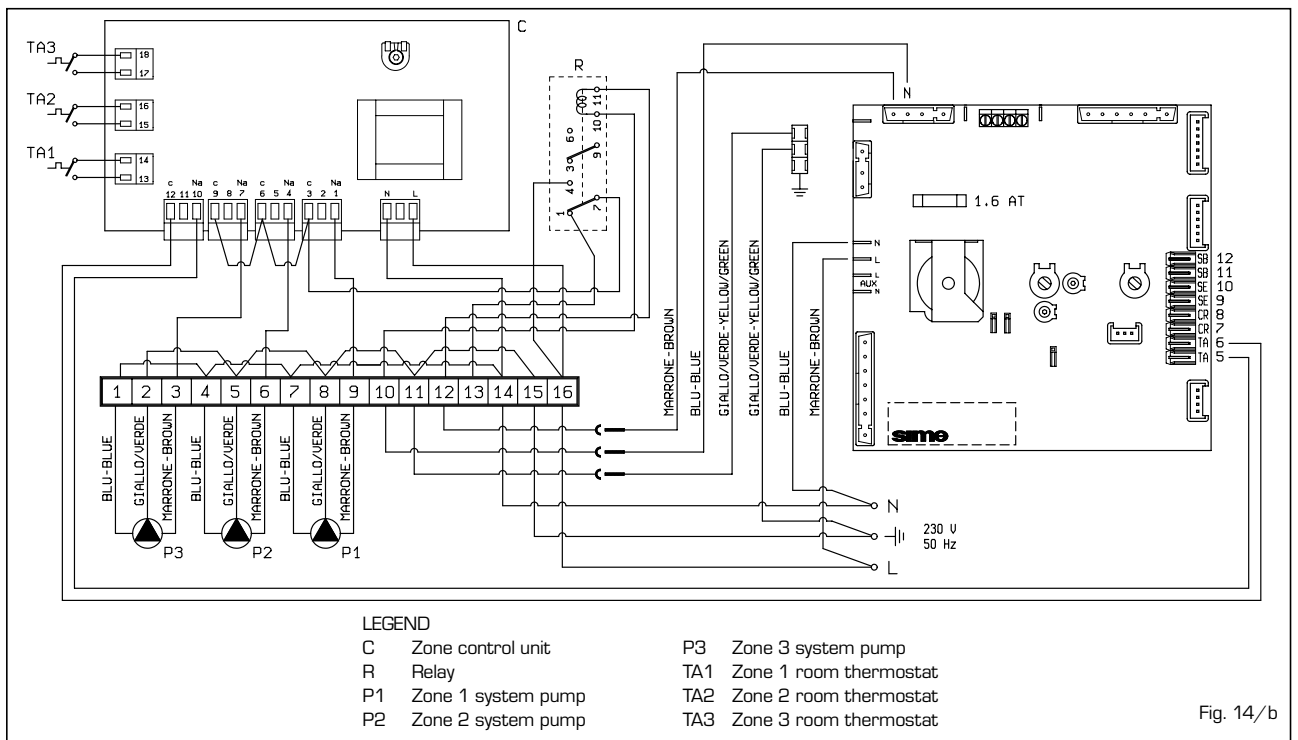

Fig. 14/b

2.8.7 "30/130" wiring diagram with low temperature kit code 8100760

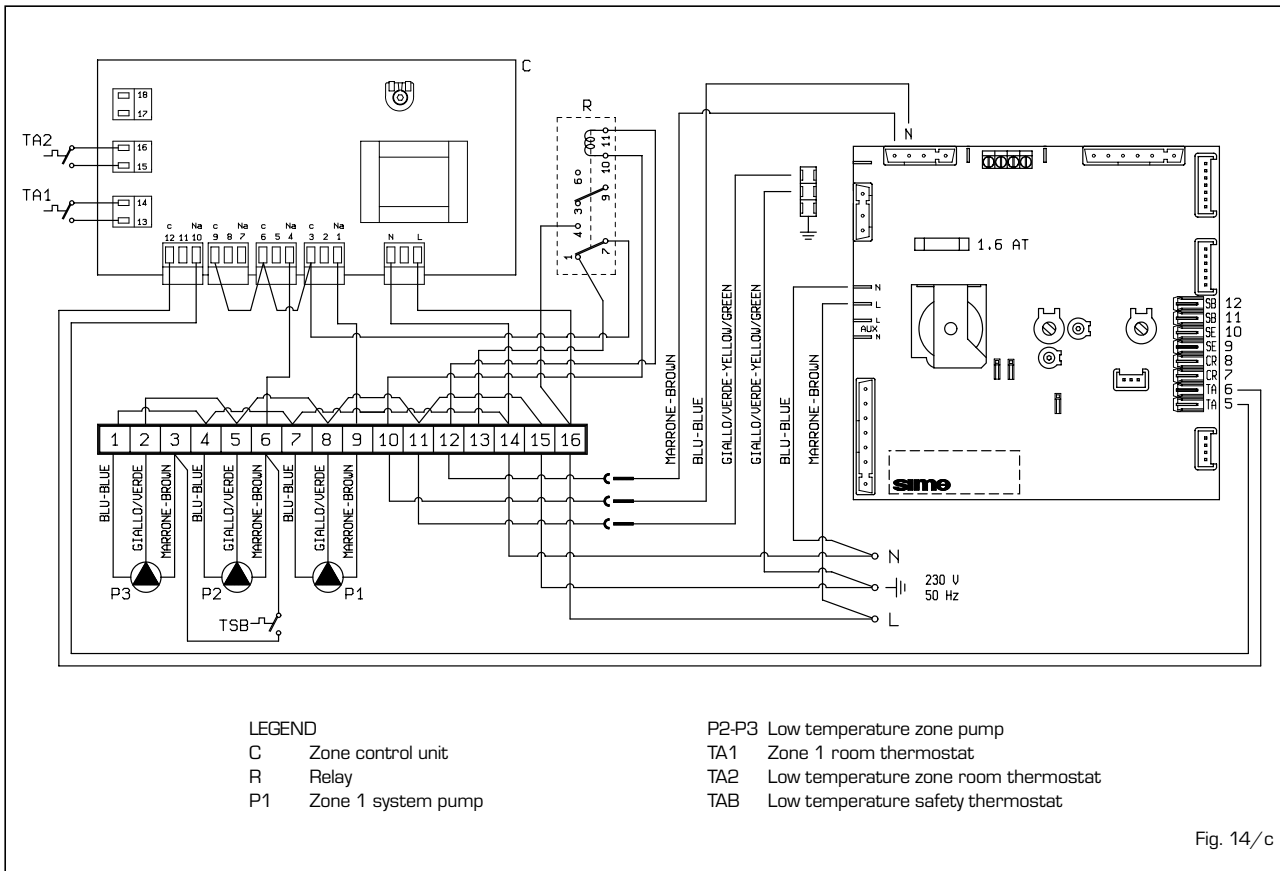

Fig. 14/c

2.9 LOGICA REMOTE CONTROL

All the boiler's functions can be managed by a optional digital multifunctional device code 8092204 for the remote of the boiler itself and for regulating room climatic conditions with an operational reserve of 12 hours.

The heating circuit is controlled by the room temperature sensor built-in the equipment or by the atmospheric conditions, with or without environmental inflow, if the boiler is connected to an external sensor:

Characteristics:

- Ergonomic control unit divided according to function (control levels)).
- Clear division of basic functions:
 - operating regime, correction of set value and presence button are directly accessible;
 - Different real current values are accessible through the "info" button;
 - other functions can be programmed after the cover has been opened;
 - special service level with protected access;
- Each setting or modification is displayed and confirmed.
- Tome setting (special line for changing BST/CET).
- Heating programme with max. 3 heating periods per day, individually selectable.
- Copy function for easy transfer of heating programme to the next or pre-

vious day.

- Holiday programme: the programme is interrupted for the holiday period and automatically restarted on returning home.
- Option to return the heating program to default values.
- Programming lock (child safety).

Functions:

- Delivery temperature control guided by the atmospheric conditions, taking into account the dynamics of the building.
- Delivery temperature control guided by atmospheric conditions with influence of ambient temperature.
- Ambient temperature control only.
- Adjustable influence of ambient temperature shift .
- Switch-on and switch-off optimisation.
- Rapid lowering.
- ECO functions (daily heating limiter, automatic summer/winter switch-over).
- Controllable maximum delivery temperature limit (specifically for floor plants).
- Limitation of increase in pre-set delivery temperature.
- Anti-freeze protection for buildings.
- Hourly programming of the tank unit temperature on two levels: comfort and reduced.
- Domestic hot water control with nominal value requirement and enable.
- Connection to room sensor or switching of operating regime through the telephonic system with external contact or

through a window contact.

- Anti-bacterial.

2.9.1 Installation

The unit must be installed in the main living room. For installation, follow the assembly instructions inserted in the package.

At this point, with the selector knob on (E), the installer can adjust the basic parameters settings according to the individual needs (point 2.8.2).

If there is a thermostatic radiator valve fitted, this must be set to maximum.

2.9.2 Installation settings

The settings for the basic operating parameters for individual needs are reported in the instruction leaflet supplied with the "Logica Remote Control" and in the section reserved for the user in this manual.

For further adjustments which can be carried out by the installer, the "Logica Remote Control" offers a level of service and parameterising which can only be accessed through a special combination of buttons.

To activate this level of service or parameterising press buttons ▲ and ▼ least 5 seconds. This will activate the parameterising level. Then use the same arrow buttons to select the individual input lines and adjust the values with - or +.

IT

ES

PT

GB

HEATING CIRCUIT SETTINGS

Antifreeze protection "Pre-set ambient temperature value"	51	Heating takes place up to this pre-set value if the plant is activated in standby (e.g. holidays). In this way, the building antifreeze function is active, preventing an excessive lowering of the ambient.
Summer/Winter switch-over temperature	52	This parameter regulates the temperature of the automatic summer/winter switch-over.
Type of control: 0 = with ambient influence 1 = without ambient influence	53	This parameter de-activates the ambient influence and as a result all the optimisations and adaptations. If a valid external temperature is not transmitted, the controller switches to the pure ambient control guide variable.
Influence of ambient temperature	54	If the ambient controller is used only as a remote control (placed in the reference room and without an external sensor connected), the value must be set at 0 (zero). If the change in ambient temperature from the pre-set value remains high during the entire day, the influence must be increased. If the ambient temperature is around the pre-set value (control oscillation), the influence must be reduced. Note: If the ambient temperature influence constant is set at 0, the adaptation of the heating curve is deactivated. In this case, parameter 57 will have no effect at all.
Maximum limit of delivery temperature	55	The delivery temperature is limited to the maximum set value.
Variation of the maximum speed of the delivery temperature	56	The increase per minute of the prescribed delivery temperature value sent in °C is limited to the imposed value.
Activation of adaptation	57	With the activation of the adaptation, the pre-set value transmitted to the boiler regulator is adapted to the effective heat need. The adaptation functions with both the atmospheric guide with ambient influence and with pure ambient control. If the "Logica Remote Control" is set as a remote control only, the adaptation must be is deactivated.
Optimisation of switch-on time	58	If the switch-on time optimisation is active, the "Logica Remote Control" modifies the heating gradient until it finds the optimum heating point 0 = off 1 = on
Heating gradient	59	The "Logica Remote Control" selects the switch-on time such that the set value has more or less been reached at the start of the usage time. The more severe the night-time cooling, the earlier the heating time starts. Example: Current ambient temperature 18.5°C Nominal ambient temperature 20°C Heating gradient 30 min/K Presetting of switch-on time: 1.5 K x 30 min/K = 45 minutes 00 means that the switch-o time has not been pre-set (function disabled).
Presetting switch-off time (00 = off)	60	If the switch-off time optimisation is active (value > 0), the "Logica Remote Control" modifies the pre-set time until it finds the optimum switch-off time..

DOMESTIC HOT WATER SETTINGS

Reduced domestic hot water pre-set value	61	The reduced pre-set value of the temperature of the domestic hot water allow the required water temperature to be obtained outside the programmed usage times (daily programme 8).
Domestic hot water load	62	<p>0 = 24 hours/ day - Hot water is always available at the temperature set with user parameter n°3.</p> <p>1 = standard - Hot water according to the daily heating programme. In the comfort areas of heating the temperature of the boiler unit is regulated to the value set with user parameter n° 3. In the reduced areas of heating the temperature of the boiler unit is regulated to the value set with parameter n° 61 of the service level.</p> <p>2 = service disconnected</p> <p>3 = second daily programme (8) - Every day of the week the temperature of the hot water is set according to programme 8. In this case there is a single programming for all the days of the week and three time zones are available. In the time spans set the temperature of the boiler unit is regulated according to that set in parameter n°3. In the remaining hours the boiler unit is controlled to the temperature set with parameter n° 61 the of service level.</p>

SERVICE VALUES

Final user level 2 programming block	63	<p>This block (1) can be activated to display all the parameters without modifying them. Pressing buttons [] or [+] displays "OFF".</p> <p>WARNING: The activation block can be deactivated temporarily by pressing buttons [▲] and [+] simultaneously; a confirmation sign appears on the display. At this point press simultaneously the buttons [▲] and [▼] for at least 5 seconds. To permanently remove the activation block, set parameter 63 on 0.</p>
Input function terminal 3-4	64	<p>The freely programmable input (terminals 3-4) allows three different functions to be activated. The parameter has the following significance:</p> <p>1 = If an external sensor is connected, the display will show the temperature of the external sensor (_ _ = no sensor connected, function disabled).</p> <p>2 = With an external contact, it is possible to switch-over to "reduced pre-set value of the ambient temperature".</p> <p>3 = With an external contact, it is possible to switch-over to "reduced pre-set value of the antifreeze ambient temperature" (short circuit 0 0 0 or interruption _ _ _). The display shows the current status of the external contact.</p>
Modo de acção do contacto externo	65	<p>Se a entrada (bornes 3 e 4 do ropadé) está ligada a um contacto externo de potencial zero (parâmetro 64 = 2 ou 3), pode ser determinado o modo de acção do contacto (tele-interruptor do telefone ou contacto janela). O modo de acção especifica o estado de contacto no qual a função desejada está activa.</p> <p>Display: modo de acção fechado (curto-circuito) 0 0 0 modo de acção aberto (interrupção) _ _ _</p>
Influxo das sondas ambiente + externa	66	<p>Determina o coeficiente de mistura entre a sonda ambiente interna e externa, quando o parâmetro 64 = 1.</p> <p>0 % = activa só a sonda interna (0% externa - 100% interna) 50 % = valor médio da sonda externa + interna 100 % = activa só a sonda externa</p> <p>Para a regulação ambiente e a visualização, é utilizada a mistura programada. Se a sonda externa apresenta um curto-circuito ou uma interrupção prossegue-se com a sonda interna.</p>
Anti-bacterial function	69	<p>This function allows the hot water to be brought to a high temperature once a week in order to eliminate eventual pathogenic agents. It is active every Monday for a maximum duration of 2.5 hours at a delivery temperature of 65°C.</p> <p>0 = not active 1 = active</p>

2.9.3 Gradient of the characteristic heating curve

The gradient of the characteristic heating curve is imposed on the current value "15" of Logica. Increasing the gradient as shown in the drawing of fig. 15, the delivery temperature increases in correspondence to the outside temperature.

2.10 EXTERNAL TEMPERATURE SENSOR

The "Logica Remote Control" can be connected to an external temperature sensor available as an optional extra (code 8094100).

This configuration ensures and maintains the required temperature constant in the room.

The ambient temperature is, in fact, indicated and evaluated as the calculated mean of the value measured inside and outside the dwelling.

For installation, follow the assembly instructions inserted in the package.

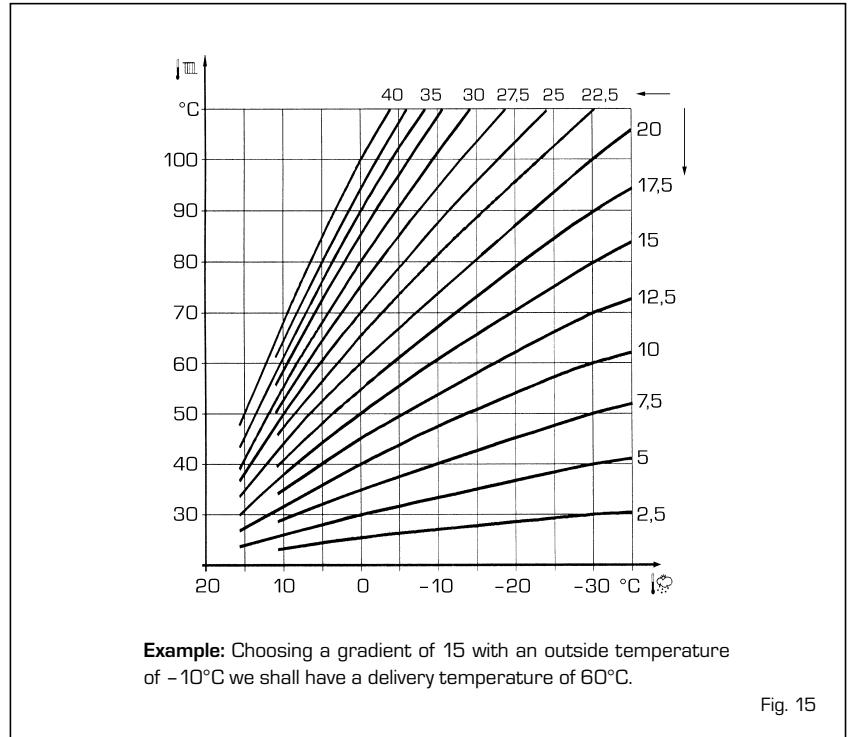

Fig. 15

3 CHARACTERISTICS

3.1 ELECTRONIC BOARD

The electronic boards are manufactured in compliance with the EEC 73/23 low-voltage directives.

They are supplied with 230V and, through a built-in transformer, send a voltage of 24V to the following components: gas valve, safety stat, C.H. and D.H.W. sensor; external temperature sensor (optional), modulator; micro divertor valve, flow switch safety valve, water pressure transducer; room stat or "Logica Remote Control".

An automatic and continuous modulation system enables the boiler to adjust the heat output to the various system requirements or the User's needs.

The electronic components are guaranteed against a temperature range of 0 to $+60^{\circ}\text{C}$.

3.1.1 Fault finding

The indicator leds signalling irregular and/or incorrect operation of the equipment are indicated in fig. 16.

3.1.2 Devices

The electronic board is equipped with the following devices:

- "POT. RISC." trimmer (10 fig. 17)
Sets the maximum heating power value. To increase the value turn the trimmer clockwise; to reduce the value turn the trimmer anticlockwise.
- "POT. ACC." trimmer (6 fig. 17)
Trimmer to vary the pressure level upon

ignition (STEP), of the gas valve.

According to the type of gas for which the boiler is equipped, the trimmer must be regulated so as to obtain a pressure of approx. 3 mbar at the burner for methane gas and 7 mbar for propane gas (G31).

To increase pressure, turn the trimmer clockwise; to reduce pressure, turn the trimmer counterclockwise.

The slow ignition pressure level can be set during the first 3 seconds following burner ignition.

After setting the pressure level upon ignition (STEP) according to the type of gas, check that the pressure for heating is still at the value previously set.

- "MET-GPL" connector (7 fig. 17)
With the connector **switched-off**, the

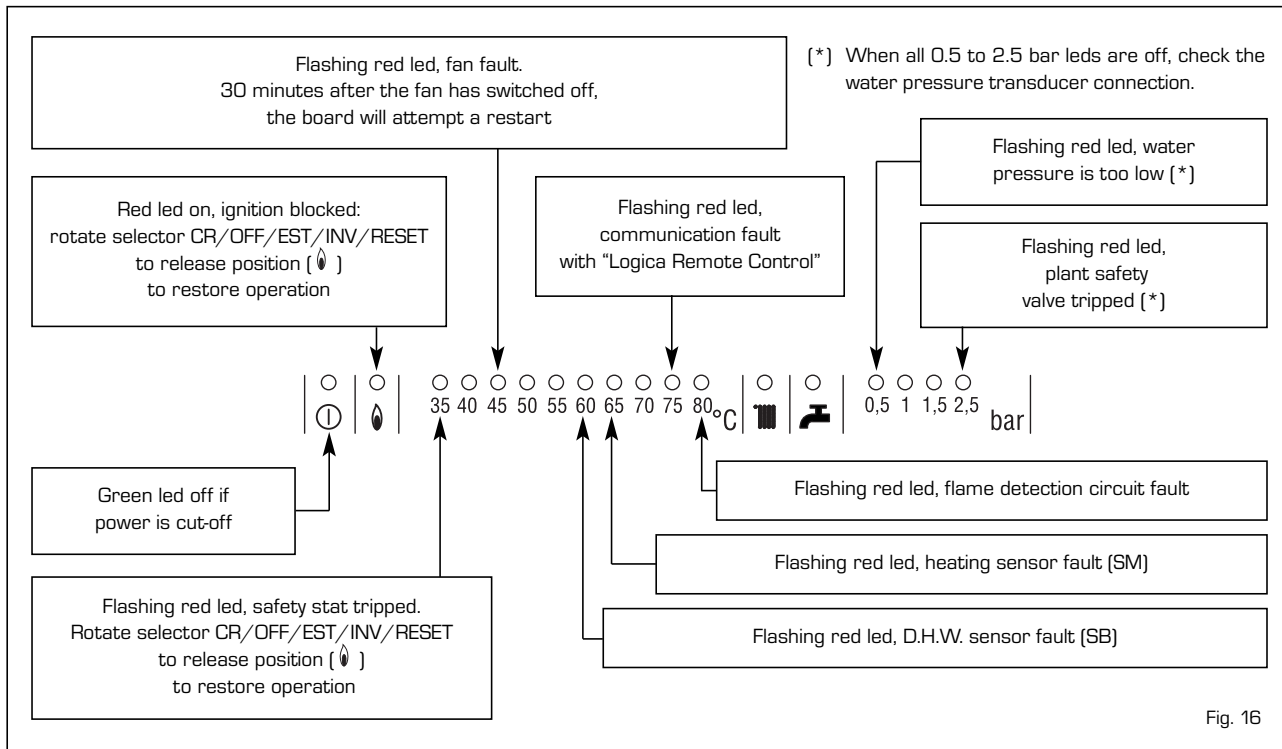

boiler is set-up for NATURAL GAS; with the connector **switched-on**, the boiler is ready for LPG.

- "ANN. RIT." connector (5 fig. 17)

In the heating phase, the electronic board is programmed to include a burner technical delay interval of approx. 90 seconds, which occurs both at system cold starting and at subsequent re-ignitions. The aim is to overcome the problem of repeated ignitions and turning off with very short time intervals between. This could

occur in particular in systems presenting high head losses.

At each restart after the period of slow ignition, the boiler will set itself for about 1 minute at the minimum modulation pressure, and will then move to the heating pressure value set.

When the connecting link is inserted, both the programmed technical pause and the period of operation at minimum pressure in the startup phase will be cancelled. In this case, the times elapsing between turning off and subsequent re-

ignition will depend on a temperature difference of 5°C detected by the SM sensor (heating flow sensor).

- DIP SWITCH (13 fig. 17)

Check that the cordless plugs are inserted in the position indicated:

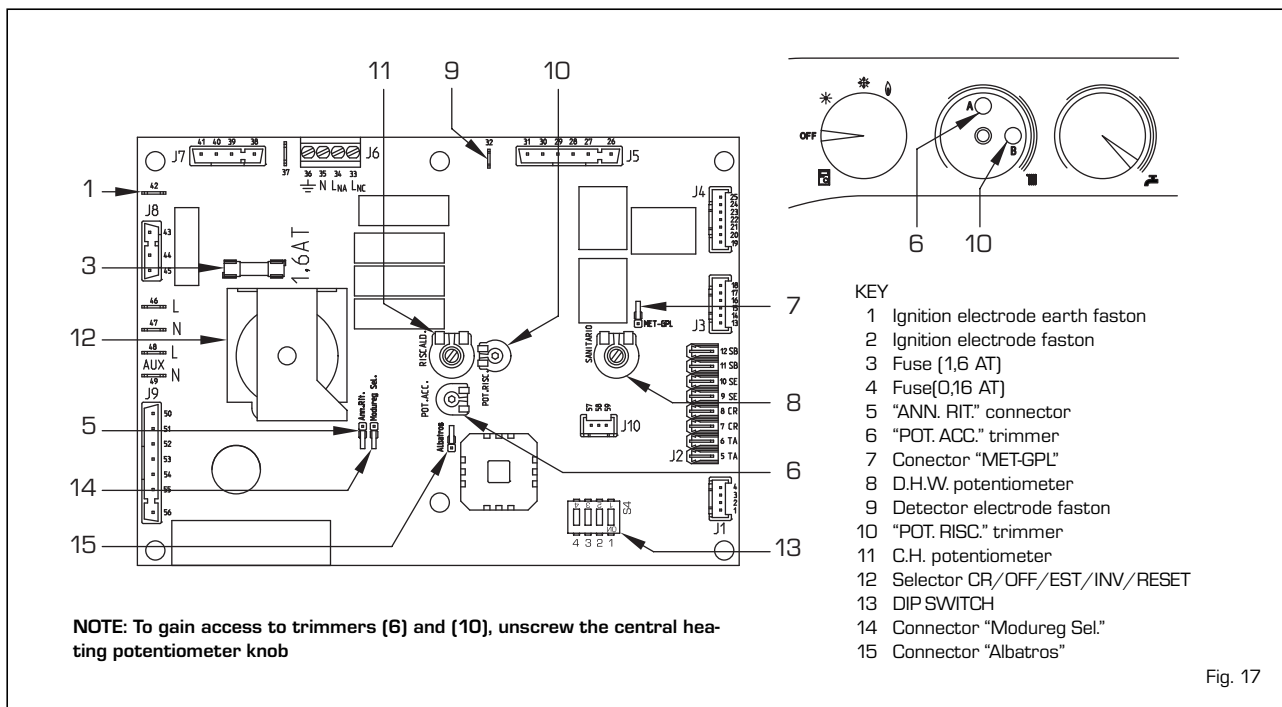
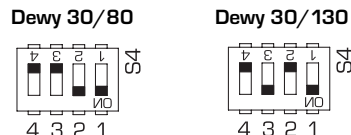

- **“Modureg Sel.” connector** (14 fig. 17)
With the bridge disconnected the boiler is predisposed to function with the SIT gas valve, and with the bridge connected it is predisposed to function with the HONEYWELL gas valve.
- **“Albatros” connector** (15 fig. 17)
The bridge must always be disconnected. It is connected only when multiple boilers are installed in a sequence/cascade.

ATTENTION: It is essential that the operations described above be carried out by authorized technical staff.

3.2 TEMPERATURE SENSOR AND WATER PRESSURE TRANSDUCER

Tables 3 - 3/a show the resistance values (Ω) that are obtained on the sensor as the temperature varies and the transducer values obtained as the pressure varies.

When sensor (SM) is interrupted, neither of the boiler's heating services will function. With D.H.W. sensor (SB) interrupted, the boiler will only work in heating mode.

TABLE 3 (Sensors)

Temperature ($^{\circ}$ C)	Resistance (Ω)
20	12.090
30	8.313
40	5.828
50	4.161
60	3.021
70	2.229
80	1.669

TABLE 3/a (Transducer)

Pressure (bar)	Resistance (Ω)	
	min	max
0	297	320
0,5	260	269
1	222	228
1,5	195	200
2	167	173
2,5	137	143
3	108	113
3,5	90	94

3.3 ELECTRONIC IGNITION

Ignition and flame detection is controlled by two electrodes located on the burner. These guarantee maximum safety with intervention times, for accidental switching off or gas failure, of within one second.

3.3.1 Operating cycle

Rotate the selector knob to summer or winter, and verify that green led (\odot) lights up to confirm the presence of voltage. The burner must be ignited within 10 seconds. However, it is possible for ignition

failures to occur, with consequent activation of signal indicating that the control box has “locked out”.

- **Gas failure**
The control box runs through the cycle normally sending electric power to the ignition electrode. The electrode continues spark discharge for a maximum of 10 sec. If the burner does not light, the lock-out indicator will light up. This may occur upon first ignition or after long periods of boiler lay-off when there is air in the pipes. It may be caused by the gas cock being closed or by one of the valve coils having a break in the winding, so that the valve cannot open.
- **Ignition electrode fails to spark**
In the boiler, only the gas to the burner is seen to open. After 10 sec. the warning light indicating equipment “lock-out” lights up. This may be due to a break in the wire of the electrode or to the wire not properly fastened to the electric terminal of the control box;
- **No detection of flame**
The continuous spark discharge of the electrode is noted starting from ignition even though the burner is lit. After 10 seconds have elapsed, the sparks cease, the burner goes out, and the warning light indicating equipment

“lock-out” lights up. There could have a break in the wire of the sensing electrode or the electrode itself is touching earth: the electrode is worn out and needs replacing. The control box is defective.

When there is a sudden voltage failure, the burner shuts out immediately; when power supply returns, the boiler will start up again automatically.

3.4 FLOW SWITCH SAFETY VALVE

A flow switch safety valve (17 fig. 3) intervenes, blocking the operation of the burner if the boiler is without water due to the formation of an air lock in the heat exchanger or if the circulator is not working, or, model “30/80”, because the “Aqua Guard Filter System” is obstructed with impurities.

NOTE: If replacing the flow switch valve, make sure that the arrow stamped on the valve points in the same direction as the flow of water.

3.5 SYSTEM AVAILABLE HEAD

For boilers with the standard fittings, the residual head for the heating system on the basis of rate of flow is represented in the diagram in figure 18.

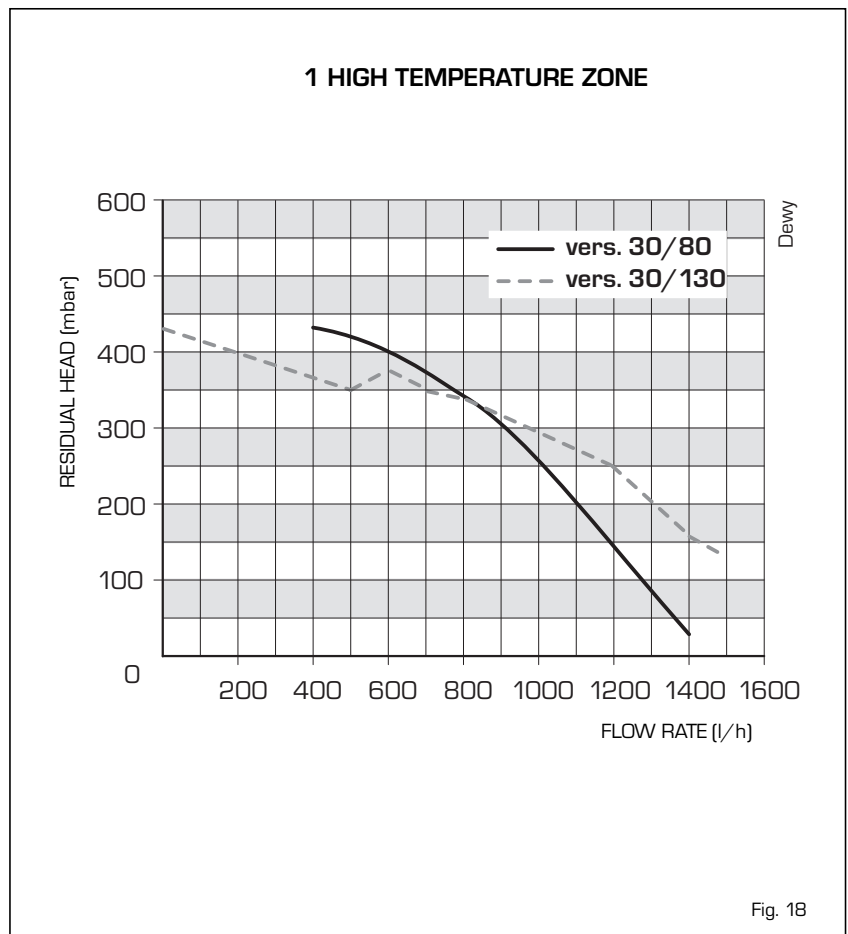

Fig. 18

3.5.1 Head with total rate of flow to other zones

In "30/130" versions using the second and third zone kit, determine the head available to the zones as shown in the following example:

Rate of flow calculated for zone 1 = 350 l/h
 Rate of flow calculated for zone 2 = 400 l/h
 Rate of flow calculated for zone 3 = 400 l/h

To obtain head available to zone 1, add the

total rate of flow to the other zones (in this case zones 2 and 3): 400 l/h + 400 l/h = 800 l/h.

As shown in the graph (fig. 18/a) at the 800 l/h curve, head at 350 l/h for zone 1 = 180 mbar.

The same procedure may be applied to other zones to obtain:

Zone 2 = 350 l/h + 400 l/h = 750 l/h.
 As shown in the graph at the 800 l/h curve, head at 400 l/h = 160 mbar.

Zone 3 = 350 l/h + 400 l/h = 750 l/h.
 As shown in the graph at the 800 l/h curve [curve E], head at 400 l/h = 160 mbar.

3.5.2 Head available with the low temperature kit

In "30/130" versions using the low temperature kit, residual available head on the basis of rate of flow is represented in the graph in fig. 18/b.

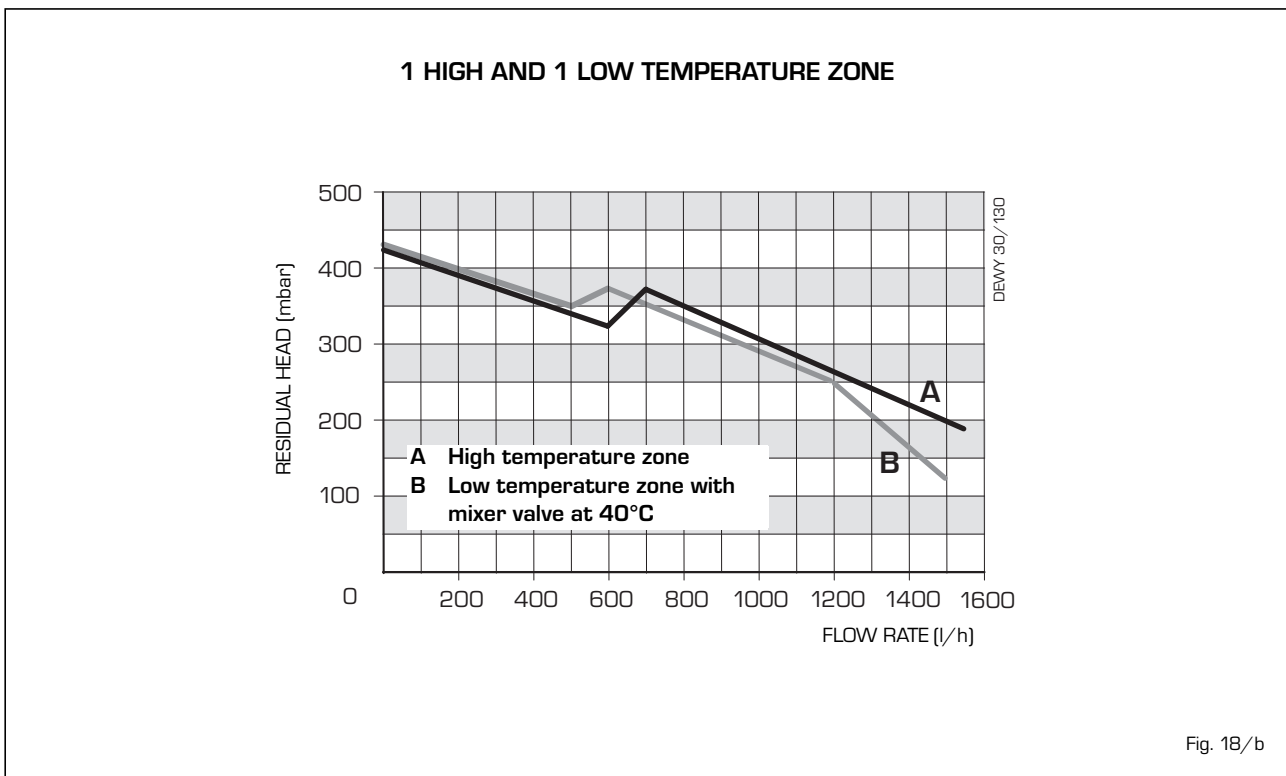
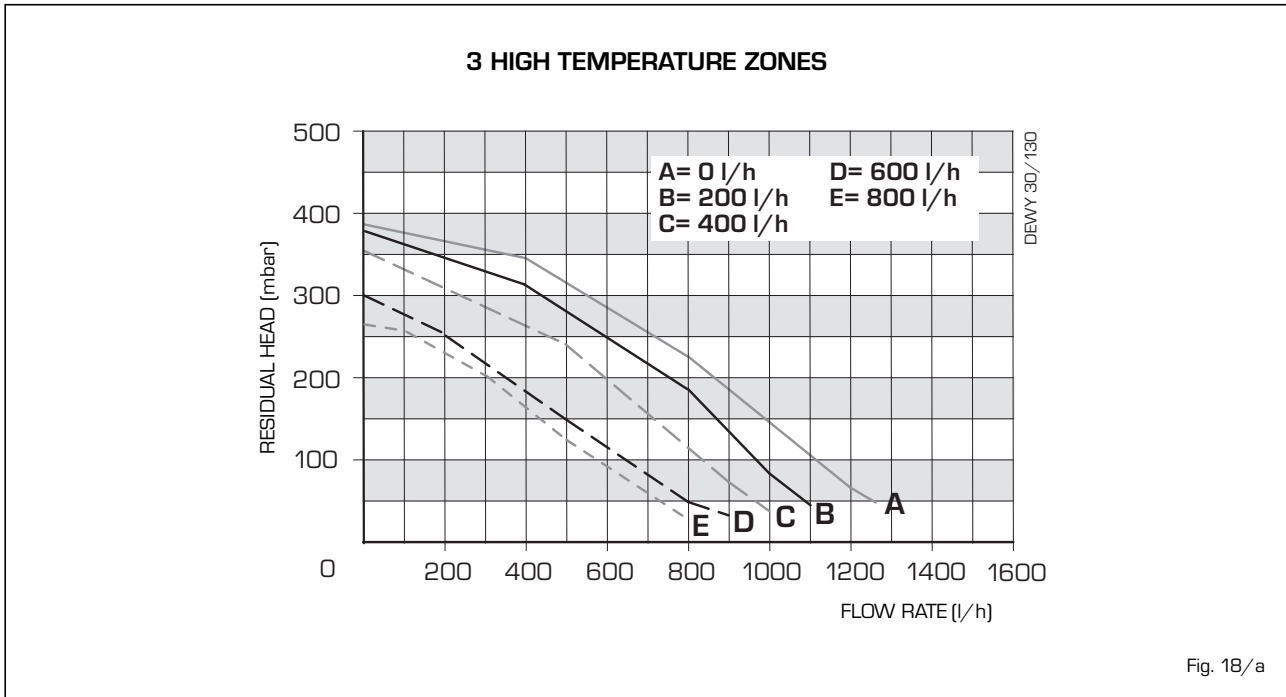

3.6 SMOKE STAT

To protect the polypropylene conduit from smoke the appliance is provided with an exhaust thermostat [27 fig. 3 - 42 fig. 3/a].

3.7 MAINS ELECTRICITY CONNECTION

Use a separate electricity supply to connect the room stats and relative zone valves or

pumps.

The micro or relay contact connection is made to TA-CR-SE (J2) connector of the circuit board after having removed the jumper (fig. 19).

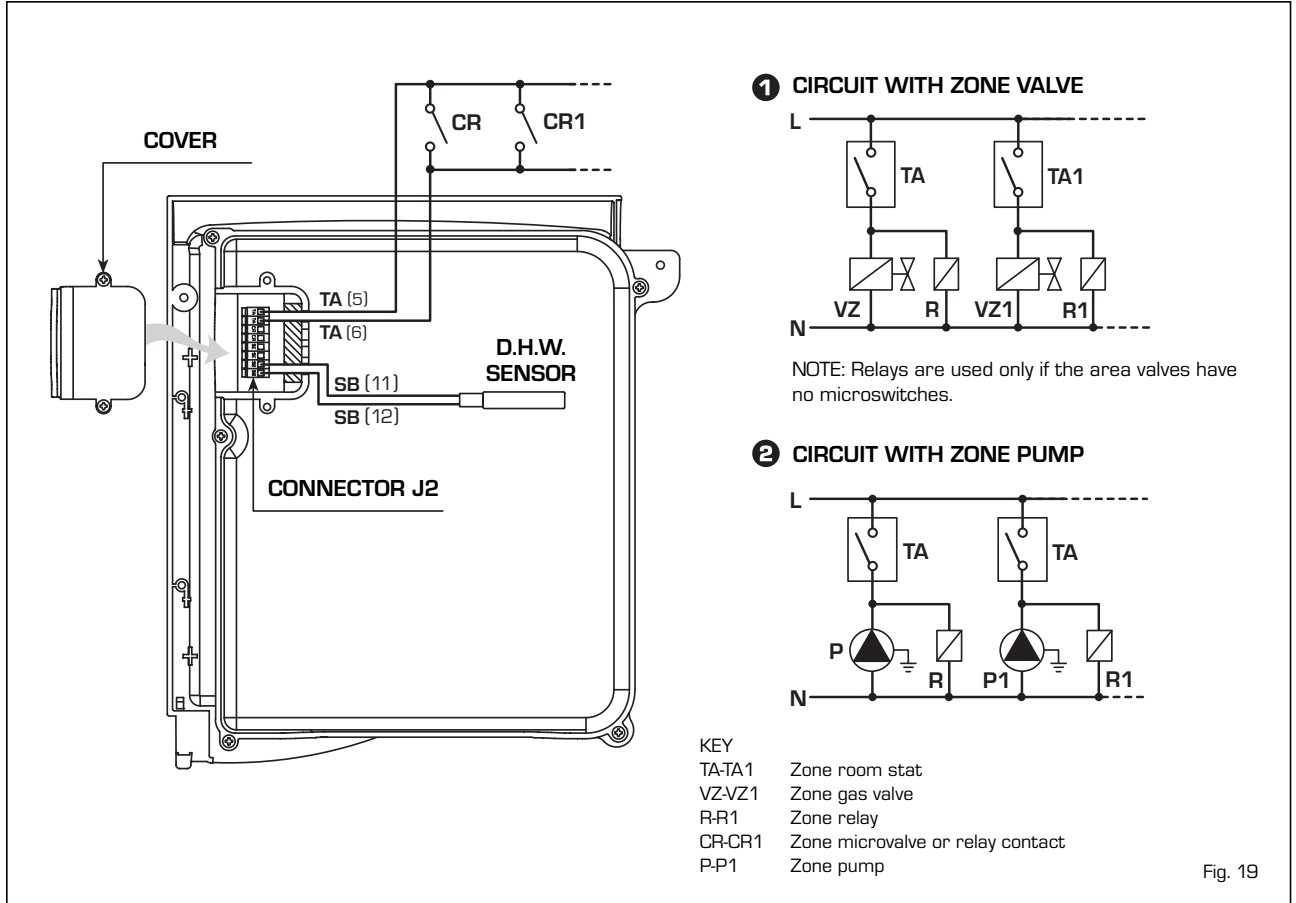

Fig. 19

4 USE AND MAINTENANCE

4.1 D.H.W. PRODUCTION

The preparation of hot water is guaranteed by the glass storage tank unit with magnesium anode for the protection of the boiler unit and inspection flange for its control and cleaning.

The magnesium anode must be checked annually and substituted when it is worn.

It is advisable to place a sluice gate at the entrance of the D.H.W. tank unit which, apart from the total closure, allows the regulation of the supply capacity.

If the boiler does not produce hot water, make sure that the air has been released by pressing on the manual vents after having switched off the main switch.

4.2 GAS VALVE

The boiler, is equipped standard with the HONEYWELL VK 8115M gas valve (fig. 20).

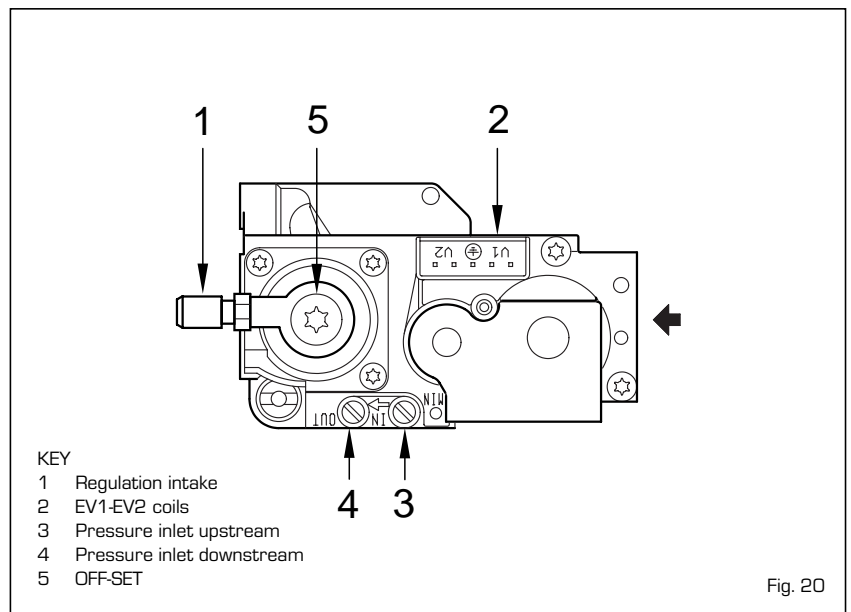

Fig. 20

4.3 ADJUSTMENT OF HEAT OUTPUT FOR HEATING

To adjust boiler heat output for heating purposes, i.e., modifying the setting made at the factory which is approximately 17 kW, use a screwdriver to adjust the heating heat output trimmer (10 fig. 17).

To increase working pressure, turn the trimmer clockwise; to reduce pressure, turn the trimmer counterclockwise.

To determine boiler heat output setting, check energy consumption by observing the meter and then compare with the values shown in **Tables 4 - 4/a - 4/b**; or measure "air Δp " with a digital pressure gauge connected up as shown in fig. 21.

Compare values with those shown in **Tables 4 - 4/a - 4/b**.

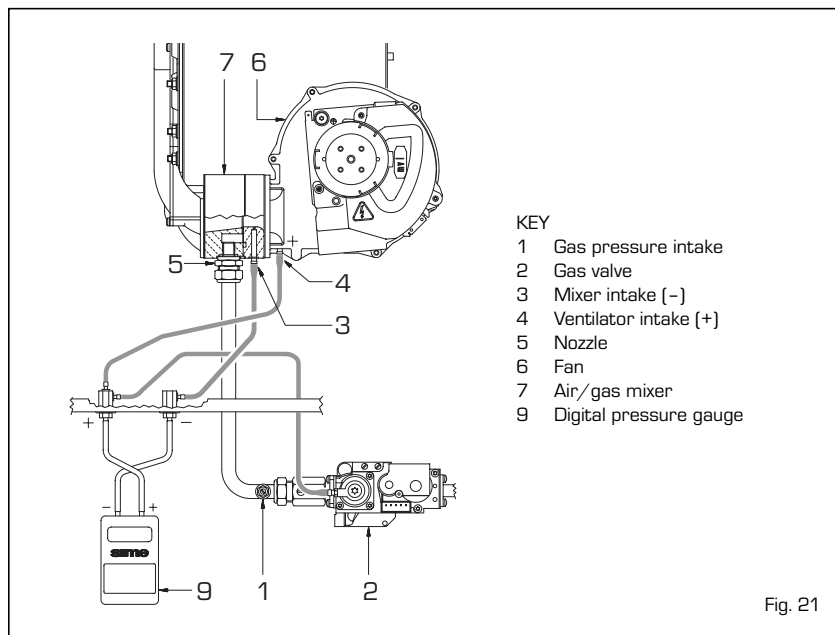

Fig. 21

4.3.1 Diagram illustrating heat output in relation to "air Δp "

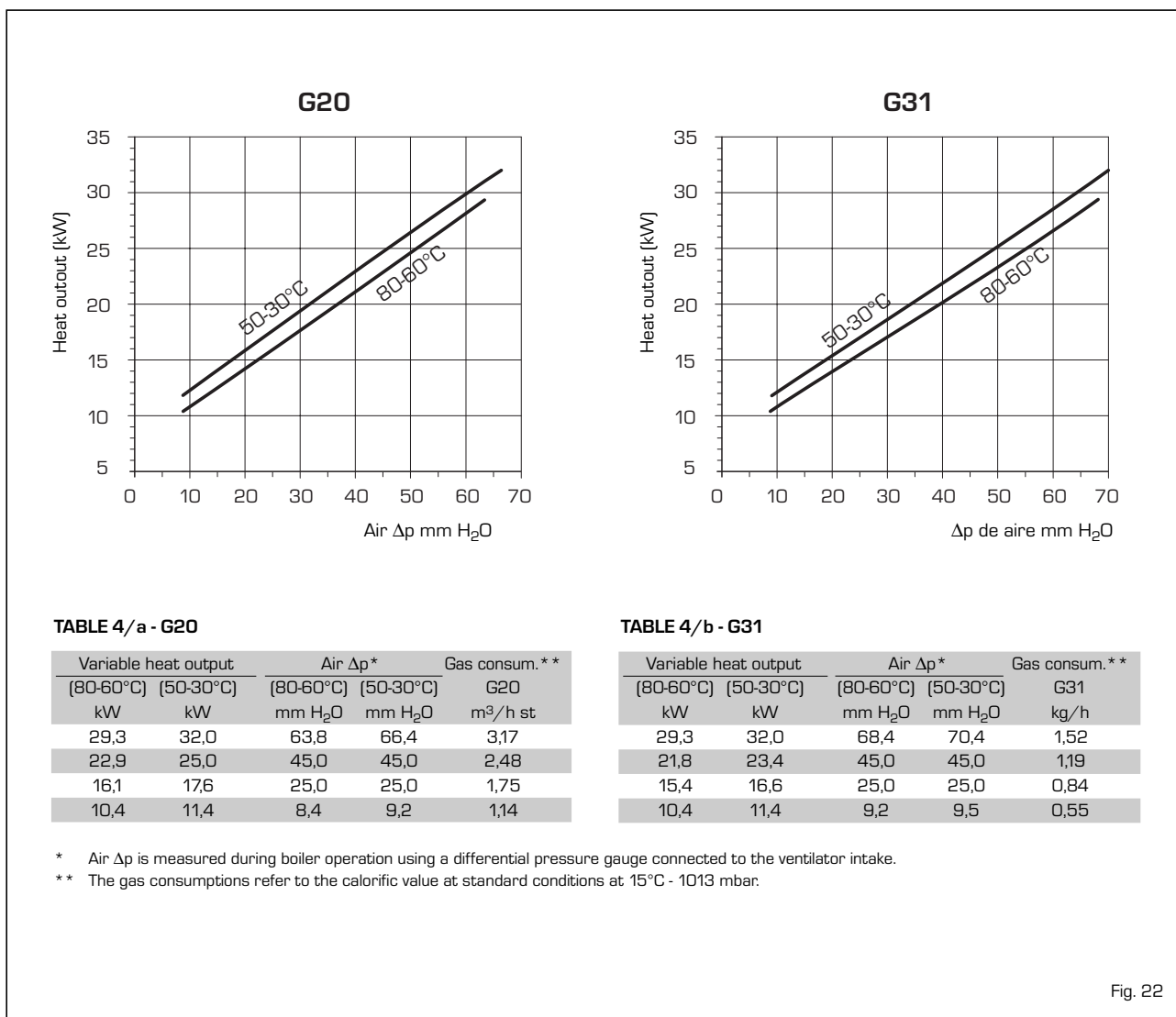

Fig. 22

4.4 BOILER CALIBRATION

The boiler must always be calibrated while set on heating.

“Δp air” ADJUSTMENT

To measure “Δp air” simply connect a differential pressure gauge with a decimal or Pascal scale to the positive and negative tap, observing the symbols (Drawing 1).

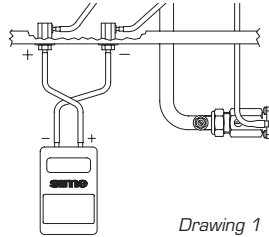

Drawing 1

Sequence of operations:

1) Turn the heating power control trimmer clockwise as far as it will go (B - Drawing 2) with the fan at its top speed.

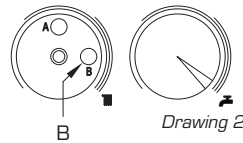

Drawing 2

2) Attempt to achieve the “Δp air” values given in the table by adjusting the MAX trimmer on the fan board (Drawing 3):

Δp air max.

Dewy	25	30
Natural gas (G20)	49,5	63,8
Propane (G31)	49,5	68,4

3) Turn the heating power control trimmer anti-clockwise as far as it will go (B - Drawing 2) with the fan at its top speed.

4) Attempt to achieve the “Δp air” values shown in the table using the “MIN” trimmer on the fan board (Drawing 3):

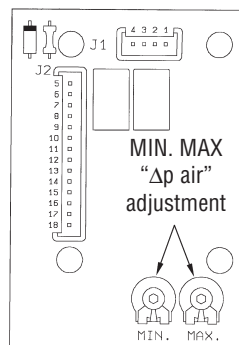

Drawing 3

Δp air min.

Dewy	25	30
Natural gas (G20)	7,1	8,4
Propane (G31)	7,1	9,2

“Δp air-gas” ADJUSTMENT

To measure “Δp air-gas”, simply connect the positive tap of the differential pressure gauge to the gas tap and the negative tap to the corresponding tap on the boiler (Drawing 4)

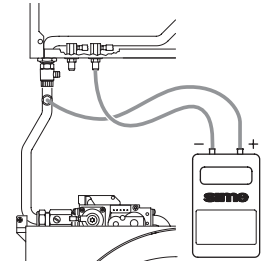

Drawing 4

Always adjust gas pressure with the fan at its top speed.

Sequence of operations:

1) Turn the heating power control trimmer anti-clockwise as far as it will go (B - Drawing 5) with the fan at its top speed.

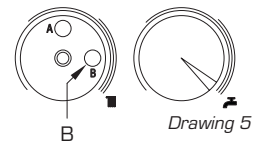

Drawing 5

2) Open the gas capacity step (1 - Drawing 6) all the way so that the notch is in a horizontal position.

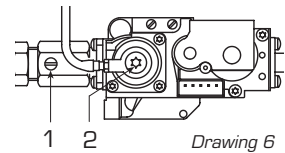

Drawing 6

3) Adjust the gas valve OFFSET regulation (2 - Drawing 6), aiming to achieve the “Δp air-gas” shown in the table:

Capacity step open

Dewy	25	30
Natural gas (G20)	7,3	7,0
Propane (G31)	8,1	10,1

4) Using the capacity step (1 - Drawing 6), attempt to achieve the “Δp air-gas” shown in the table:

Capacity step regulated

Dewy	25	30
Natural gas (G20)	5,3	6,3
Propane (G31)	4,4	9,0

Upon completion of the calibration procedure, check CO₂ values using a combustion analyser. If a difference which is more than 0.2 above or below the values indicated in the table is found, it will be necessary to correct it:

	“Dewy 25”		“Dewy 30”	
	CO ₂ (Natural gas)	CO ₂ (Propane)	CO ₂ (Natural gas)	CO ₂ (Propane)
“MIN” output	9,3	10,2	9,0	10,1
“MAX” output	8,9	10,0	9,1	10,3

- Use the OFFSET screw (2 - Drawing 6) to correct CO₂ at “MIN” output.
- Use the capacity step to correct CO₂ at “MAX” output (1 - Drawing 6).

ATTENTION:

- On PROPANE - G31 boilers it is a good idea to check that the position of the GPL bridge on the control board is correct.
- Diaphragm code 6028640 (Drawing 7) is assembled on the “Dewy 25” model functioning on PROPANE - G31 only.

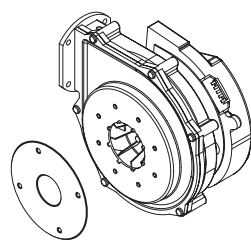

Drawing 7

- If the fan control board code 8260501 is replaced on “Dewy” models running on PROPANE - G31 it is very important to remember to cut the specified resistance (Drawing 8).

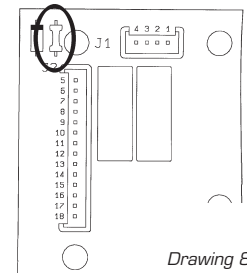

Drawing 8

Fig. 23

4.5 DISASSEMBLY OF EXPANSION VESSEL

To disassemble the expansion vessel, proceed as follows:

- Make sure that the water has been emptied out of the boiler.
- Unscrew the connection and the locknut.
- Remove the expansion vessel.

Before refilling the system, using a pressure gauge attached to the valve make sure that the expansion vessel is preloaded at a pressure of 0.8 to 1 bar.

4.6 CLEANING AND MAINTENANCE

Preventive maintenance and checking of efficient operation of equipment and safety devices must be carried out exclusively by authorized technical personnel.

During maintenance operations the authorised technician must check that the syphoned drip is full of water (this check is of importance particularly when the generator has been out of use for a long period of time). Filling is done via the special opening (fig. 24).

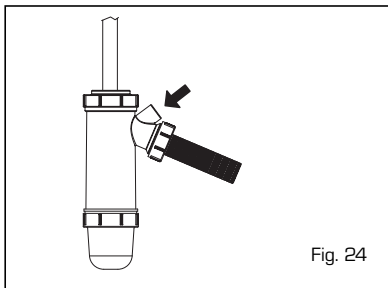

Fig. 24

4.6.1 Disassembly the control panel and skirt cover lid (fig. 25)

To remove the cover, take out the screws (1 - 2) that hold it in place on the instrument panel. Position side "A" of the bracket on the skirt side so that the instrument panel is hooked on the side in order to facilitate this operation.

4.6.2 Chimney sweep function

To carry out the verification of combustion in the boiler, turn the selector and stop on the position (I) until the orange led (IIII) starts to flash intermittently (fig. 29).

From that moment the boiler will start functioning in heating mode at the maximum power, with switching off at 80°C and restarting at 70°C.

Before activating the chimney sweep function make sure that the radiator valves or eventual zone valves are open.

The test may be carried out also during hot water functioning. To do so it is enough, after having activated the chimney sweep function, to take some hot water from one or more taps; after a few minutes the

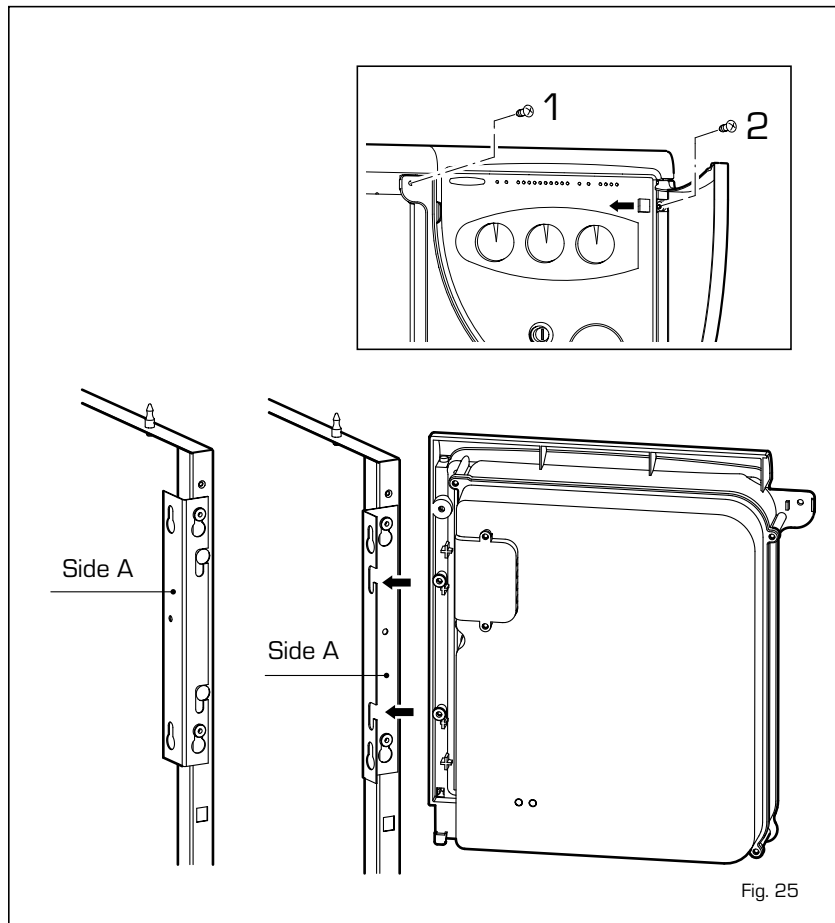

Fig. 25

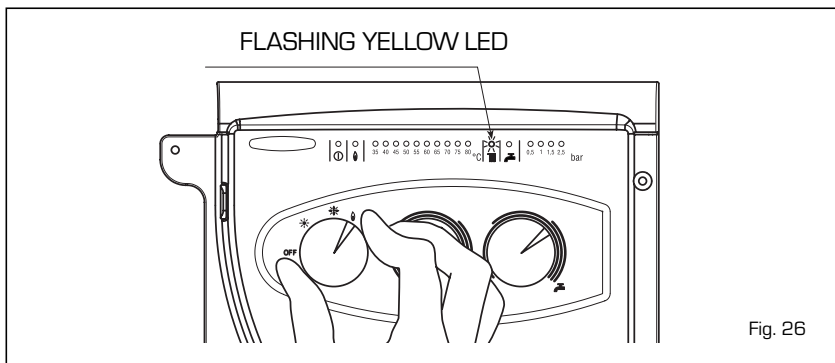

Fig. 26

request of the hot-water service feeler is activated and it automatically switches on the led (IIII). Even in this condition the boiler functions at the maximum temperature always with the primary controlled between 80°C and 70°C. During the entire duration of the testing the hot water taps must remain open. After verifying the combustion the boiler should be switched off by placing the selector on the (OFF) position; then return the selector to the desired function.

ATTENTION: After about 15 minutes the chimney sweep function automatically deactivates.

4.6.3 Cleaning the "Aqua Guard Filter System" (fig. 27)

Model "30/80", to clean the filter, close

the delivery/return on/off taps, turn off the power to the control panel, remove the casing and empty the boiler using the drain provided. Place a container for collection underneath the filter and proceed to clean the filter, removing impurities and limestone deposits. Check the seal o-ring before reassembling the cap with the filter.

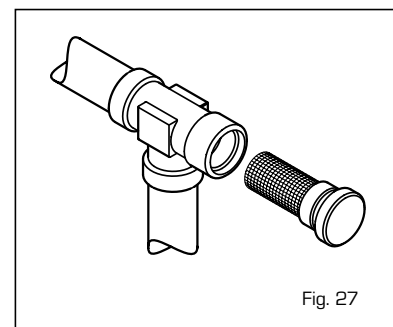

Fig. 27

USER INSTRUCTIONS

IT

ES

PT

GB

WARNINGS

- In case of fault and/or incorrect equipment operation, deactivate it, without making any repairs or taking any direct action. Contact an authorised technical staff.
- The installation of the boiler and any servicing or maintenance job must be carried out by qualified personnel. Under no circumstances, the devices sealed by the manufacturer can be tampered with.
- It is absolutely prohibited to block the intake grilles and the aeration opening of the room where the equipment is installed.

LIGHTING AND OPERATION

BOILER IGNITION (fig. 1)

Open the gas valve, lower the control panel cover and activate the boiler by rotating the selector knob to the summer position (☼). The lighting-up of the green led (⓪) will indicate that the apparatus is switched-on and ready.

- With the rotary switch in the summer position (☼) the boiler will start-up upon demand for domestic hot water,

and run at full power to reach the selected temperature.

The gas feeding pressure will then automatically vary to ensure that the required temperature is kept constant.

- With the rotary switch in the winter position (❄️) once the boiler has reached the value set on the heating potentiometer, it will start to modulate in automatically in order to supply the required power output to the system. The opera-

tion of the boiler will be stopped through the intervention of the thermostat or "Logica Remote Control".

TEMPERATURES ADJUSTMENT (fig. 2)

- The D.H.W. temperature can be adjusted by turning the knob of the D.H.W. potentiometer (⚙️).

When there is a demand for hot water, the set temperature is displayed on the red led scale from 35÷80°C and the yellow domestic hot water led lights-up at the same time (⚡).

- The C.H. temperature can be adjusted by turning the knob of the C.H. potentiometer (⚙️). The set temperature is indicated on the red led scale from 35÷80°C and the yellow heating led lights up at the same time (⚡). If the temperature of the blackflow water is lower than around 55° C, condensation of the combustion by-products is obtained, further increasing the efficiency of the thermal exchange.

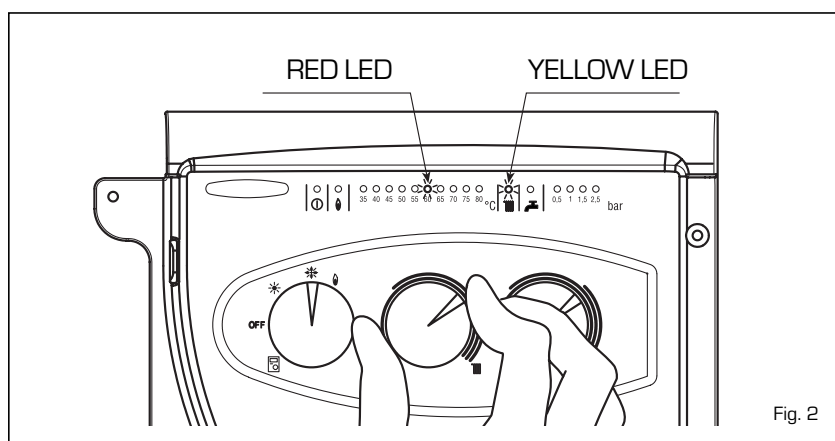
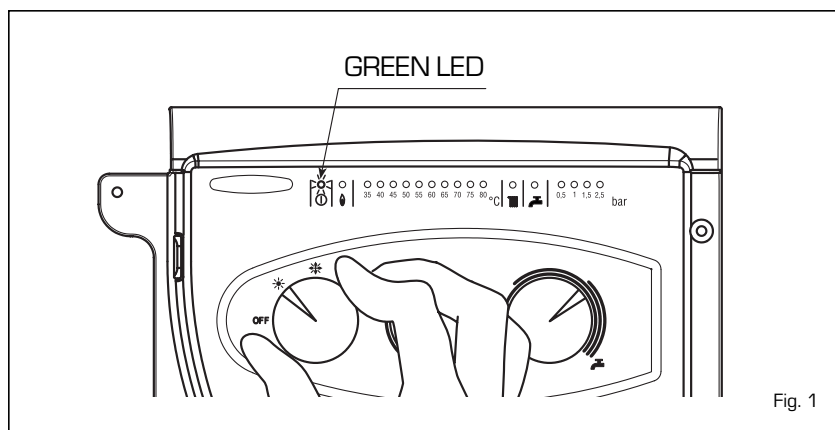

TURNING THE BOILER OFF (fig. 1)

To turn the boiler off place the selector knob on the **OFF** position. If the boiler is not going to be used for a lengthy period it is advised to turn off the electricity supply, close the gas tap, and if the temperatures foreseen are low, empty the boiler and the hydraulic system to avoid breakage in the tubes due to the freezing of the water:

GAS CONVERSION

Should it be necessary to convert the appliance to a different gas from the one for which the boiler has been equipped, approach the technical staff.





CLEANING AND MAINTENANCE

Preventive maintenance and checking

of the efficient operation of the equipment and safety devices must be carried out exclusively by the authorized technical staff.

The boiler is supplied with an electric cable. Should this require replacement, contact exclusively with the authorized technical staff.

FAULT FINDING

- **Ignition lock-out** (fig. 3)
If the burners do not ignite, the red led will light-up ().
To attempt a boiler restart, rotate the selector knob to position () and release it immediately, placing it in the summer () or winter () operation position.
If the boiler lock-out re-occurs, contact an authorised Service Centre.

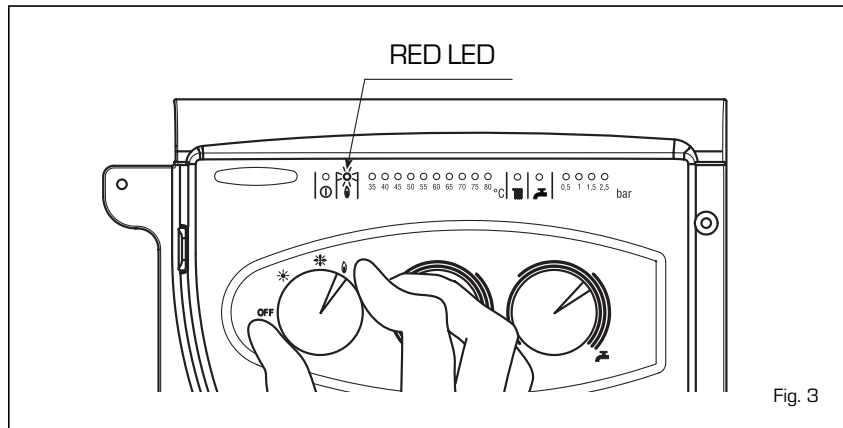

Fig. 3

- **Insufficient water pressure** (fig. 4)
If the red "0.5" bar led starts flashing, the boiler will not function.
To restart operation, rotate the charge valve anticlockwise until the green "1 bar" led lights up.
ONCE THE FILLING HAS BEEN COMPLETED, CLOSE THE FILLING TAP.
If all the leds are off, call the local authorised Service Centre for technical assistance.

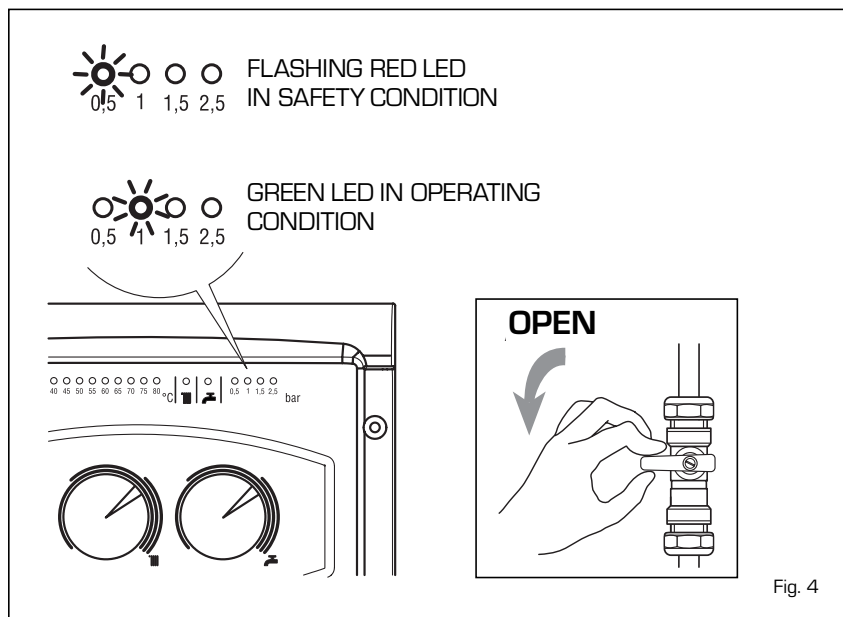





Fig. 4

- **Safety stat trip** (fig. 5)
If the safety thermostat trips, the red "35°C" led will start flashing. In order to attempt a boiler restart, rotate the selector knob to position () and release immediately, returning it to the summer () or winter () position.
If the boiler lock-out occurs again, call local authorised Service Centre for technical assistance.

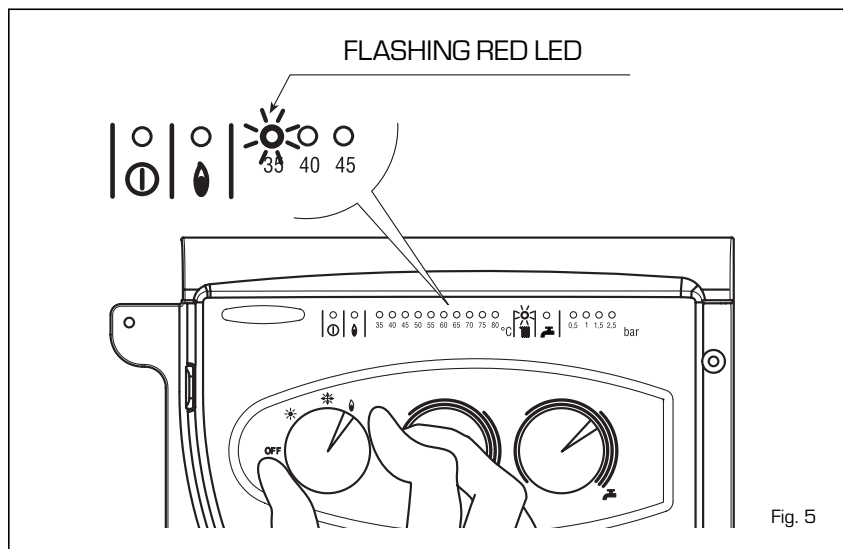

Fig. 5

- **Other anomalies** (fig. 6)
When one of the red **"40÷80°C"** leds start flashing, switch-off the boiler and then try to ignite again.
After 2 or 3 unsuccessful attempts, do not try again but call authorised technical staff.

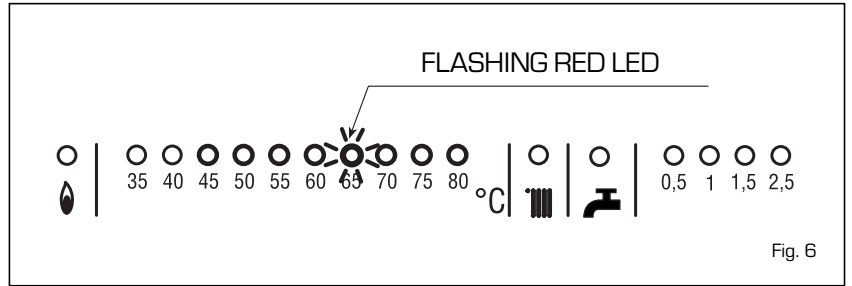

Fig. 6

LOGICA REMOTE CONTROL

When **"DEWY"** is connected to the "Logica Remote Control" regulator, the selector CR/OFF/SUM/WIN/UNBLOCK must be placed in the position (OFF); the knobs of the hot-water service heating potentiometers do not have any effect and all of the functions will be managed by the regulator (fig. 7).
If the "Logica Remote Control" breaks

down, the boiler will function by placing the selector on the (☀ o ❄), position, obviously without consequent control of the room temperature.

No interior da tampa estão indicadas as instruções de funcionamento (fig. 8). Cada programação ou modificação é visualizada e confirmada no display (fig. 9).

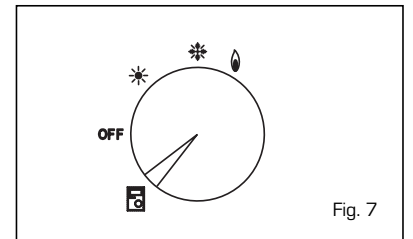

Fig. 7

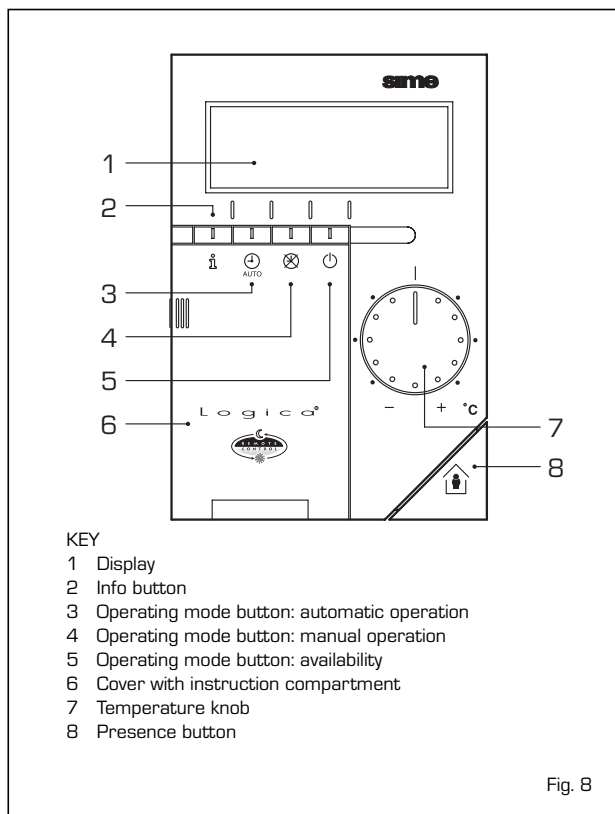

Fig. 8

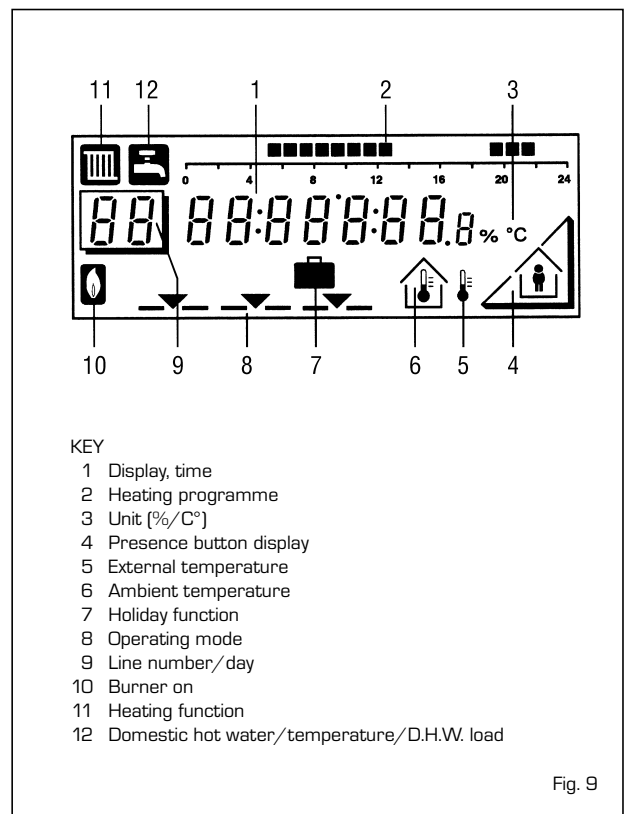
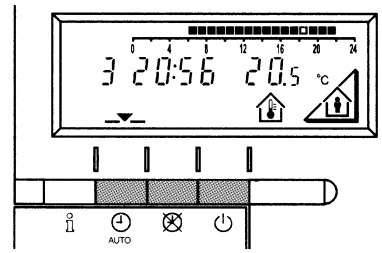



Fig. 9

ACTIVATING

During functioning the lid of the regulator must be closed.

- **Selection of the operating mode**
[reference keys grey colour]



The operating mode desired is selected by pressing the relative key with the corresponding symbol. The choice is displayed with the symbol 



Automatic functioning: the heating functions automatically according to the heating programme entered. The programme may be excluded for brief periods with the on-line key.



Manual functioning: the heating functions manually according to the choice made with the on-line key.



Availability: the heating is deactivated.

- **Info key**
[reference key grey colour]

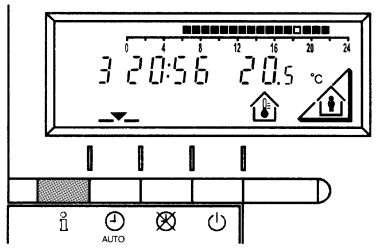

For every operation of the Info key the following list of items, one after the other, are displayed. The thermo-feeler continues to function independently of the display.



Day, hour, room temperature



External temperature*



Hot-water service temperature*

* This data appear only if the relative feeler is connected or if they are transmitted by the regulator of the boiler.

- **Adjusting the temperature**

Before adjusting the temperature of the regulator, the thermostatic valves, which may be present, have to be regulated to the desired temperature.

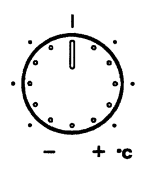

If it is too hot or too cold in your apartment, you can easily adjust the fixed temperature with the temperature knob.



If you turn the knob towards the + sign, the fixed temperature is increased by about 1 °C for every notch.



If you turn the knob towards the - sign, the fixed temperature is decreased by about 1 °C for every notch.

Before adjusting it again, however, allow the temperature to stabilise first.

Note: With the temperature knob you can only adjust the fixed temperature, whilst the reduced temperature remains the same.

- On-line key

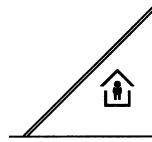



If the rooms remain unused for a long period of time, the temperature can be reduced with the on-line key, in this way saving energy. When the rooms are occupied again, press the on-line key to re-heat them. The current choice is displayed on the display:



Fixed temperature heating



Reduced temperature heating

NOTA: The choice made will work in a permanent way when manually , carried out, instead, if automatic  it will work up to the next switching according to the heating programme.

PROGRAMMING

For the programming the lid of the regulator must be open.

You can set or display the following values:

- Temperatures 1 up to 3
- Heating programme 4 up to 11
- Day of the week and hour 12 up to 14
- Current values 15 up to 17
- Vacation period 18
- Return to the default values 19

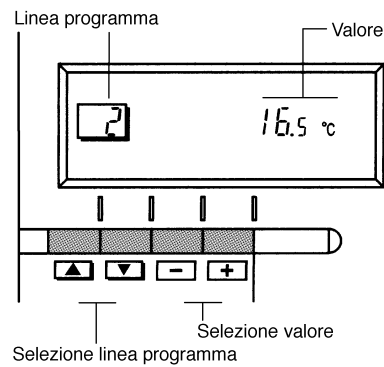









As soon as the cover is open, the display and the key functions are switched on. The number in the square represents the programme lines that may be selected with the arrow keys.

- Temperature regulation

Before proceeding with the adjustment in the temperature on the regulator, the thermostatic valves, which may be present, have to be regulated to the desired temperature.



In automatic mode, the apparatus switches from the fixed temperature to the reduced temperature according to the temporal programme. The manual switching of the temperature is done manually with the on-line key.

- 1 Fixed temperature: temperature when the rooms are occupied (basic setting) 
- 2 Reduced temperature: temperature during periods of absence or night 
- 3 Hot-water service temperature:
 - desired temperature of hot-water service
 - comfort temperature of the hot-water service (with storage capacity boiler unit) 

61 Reduced temperature of hot-water service (with storage capacity boiler unit): temperature desired for hot-water service at reduced level. To have access to the "reduced hot-water service temperature" parameter, press the  and  keys at the same time for at least 5 seconds and then go along the entered lines with the key  until parameter 61 is reached. Regulate the value with  and .

- Setting the time

- 12 To set the current day of the week (1 = Monday/7 = Sunday)
- 13 To set the current hour
- 14 To set the current minute
Once the hour is completed, the setting of the hour changes.

With  and  keys the current hour is regulated. Pressing these keys together, the regulation is speeded up in an increasing sense.

- Heating/hot-water service programme

With the heating programme it is possible to set the switching times of the temperature for a period of a week. The weekly programme consists of 7 daily programmes. One daily programme allows 3 phases of heating. Each phase is defined by a starting time and a finishing time. The n. 8 daily programme is for the hot-water service. If a phase is not required, the same starting and finishing time may be entered.

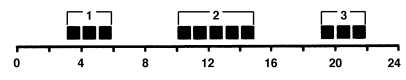

- 4** Select the days that correspond with the heating phase.
1 = Monday, ... 7 = Sunday/8 = hot-water service programme
- 5** Start of phase 1: heating with fixed modality
- 6** End phase 1: heating with reduced modality
- 7** Start phase 2: heating with fixed modality
- 8** End phase 2: heating with reduced modality
- 9** Start phase 3: heating with fixed modality
- 10** End phase 3: heating with reduced modality
- 11** Copying of the daily programme

+ By pressing this key it is possible to repeat the current heating programme for the **next day**.

- By pressing this key it is possible to repeat the current heating programme for the **previous day**.

As a confirmation the following day is displayed.

- Programme for hot-water service (with storage capacity boiler unit)

With the Logic Remote Control it is possible to manage the temperature of boiler unit on two levels (a comfort level and one at reduced temperature) in accordance with the programme chosen with parameter 62 (load hot-water service). To have access to the parameter press the **▲** and **▼** keys for at least 5 seconds and then go along the entered lines with the **▼** key until parameter 62 is reached. At this point four different programmes may be selected with **[-]** or **[+]** keys, with the following characteristics:

- 0** = 24 hours/ day - Hot water always available at the temperature set in parameter 3.
- 1** = standard - Hot water according to the daily heating programme. In the comfort periods of the heating the temperature of the boiler unit is regulated at the value set via parameter 61.
- 2** = sservice suspended.
- 3** = second daily programme (8) - Everyday of the week the temperature of the hot-water service is set according to programme B. In this case the programming is one for all the days of the week and three periods of time are available. In the periods of time set, the temperature of the boiler unit is controlled via the temperature setting of parameter 61.

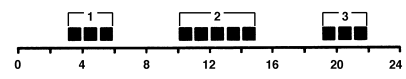

- 5** Start phase 1: preparation of the boiler unit to the comfort temperature
- 6** End phase 1: Temperature of boiler unit maintained at the reduced value
- 7** Start phase 2: Preparation of boiler unit to the comfort temperature
- 8** End phase 2: Temperature of boiler unit maintained at the reduced value
- 9** Start phase 3: preparation of boiler unit to the comfort temperature
- 10** End phase 3: Temperature of boiler unit maintained at the reduced value



- Current values

15

Display and setting of the gradient of the heating characteristics curve. When the room temperature set is not reached choose the gradient indicated in point 2.9.3

16

Display of the current boiler temperature.

17

Display of the current power of the burner and of the current operating mode (= heating/ = hot-water service)

- Vacation function

18

To enter the number of days of absence.

In the display the vacation symbol will be shown (), on the left the day of activation (1 = Monday/7 = Sunday) and on the right the number of vacation days.

NOTE:



During the vacation the regulator will be on the availability mode.



When the set days have elapsed, the regulator will go on to the automatic function.

The vacation period may be cancelled by pressing a key of the operating mode.

- Default values

19

To take the setting to the default values, press the and keys at the same time for at least 3 seconds. As confirmation a sign will appear on the display.

ATTENTION

The values of the following line numbers previously entered will be lost.

- Temperature and time programme to
- Vacation period

- Error display

Er 0

Ignition lock-out

Rotate selector CR/OFF/EST/INV/RESET on the "PLANET" control panel to the release position () to reset operation (fig. 3).
If the lock-out re-occurs, call an authorised Service Centre.

Er 1

Safety thermostat trip

Rotate selector CR/OFF/EST/INV/RESET on the "PLANET" control panel to the release position () to reset operation (fig. 5).
If the lock-out re-occurs, call an authorised Service Centre.

Er 67

Domestic hot water sensor fault (SB)

Call an authorised Service Centre.

Er 68

Heating sensor fault (SM)

Call an authorised Service Centre.

Er 69

Insufficient water pressure

Reset operation using the boiler charge valve (fig. 4).

Er 70

Plant overpressure

Call an authorised Service Centre.

Er 192

Safety thermostat trips

Call an authorised Service Centre.

Er 193

The exhaust gas pressure switch trips

Call an authorised Service Centre.

Er 195

No communication between the "Logica Remote Control" and the boiler.

Call an authorised Service Centre.



DICHIARAZIONE DI CONFORMITA' CALDAIE BASAMENTO A GAS

La **FONDERIE SIME S.p.A.**, con riferimento all'art. 5 DPR n°447 del 6/12/1991 "Regolamento di attuazione della legge 5 marzo 1990 n°46" ed in conformità alla legge 6 dicembre 1971 n° 1083 "Norme per la sicurezza dell'impiego del gas combustibile", dichiara che le proprie caldaie basamento a gas serie:

RX CE - RX 26 BF
RMG Mk.II
RS Mk.II
LOGO *
MISTRAL *
AVANT
KOMBIMAT CE
BITHERM - BITHERM BF
DUOGAS CE
DEWY *
EKO OF

sono complete di tutti gli organi di sicurezza e di controllo previsti dalle norme vigenti in materia e rispondono, per caratteristiche tecniche e funzionali, alle prescrizioni delle norme:

UNI-CIG 7271 (aprile 1988)

UNI-CIG 9893 (dicembre 1991)

UNI EN 297 per APPARECCHI A GAS DI TIPO B AVENTI PORTATA TERMICA ≤ 70 kW

EN 656 per APPARECCHI A GAS DI TIPO B AVENTI PORTATA TERMICA $70 \div 300$ kW

EN 483 per APPARECCHI A GAS DI TIPO C AVENTI PORTATA TERMICA ≤ 70 kW.

La portata al sanitario delle caldaie combinate è rispondente alla norma:

UNI EN 625 per APPARECCHI AVENTI PORTATA TERMICA ≤ 70 kW

Le Caldaie a gas sono inoltre conformi alla:

DIRETTIVA GAS 90/396 CEE per la conformità CE di tipo

DIRETTIVA BASSA TENSIONE 73/23 CEE

DIRETTIVA COMPATIBILITÀ ELETTRROMAGNETICA 89/336 CEE

DIRETTIVA RENDIMENTI 92/42 CEE

La ghisa grigia utilizzata è del tipo EN-GJL 150 secondo la norma europea **UNI EN 1561**.

Il sistema qualità aziendale è certificato secondo la norma **UNI EN ISO 9001: 2000**.

* Caldaie a basse emissioni inquinanti (**"classe 5"** rispetto alle norme europee **UNI EN 297 e EN 483**).

Legnago, 20 luglio 2004

Il Direttore Generale
ing. Aldo Gava



Rendimenti caldaie basamento a gas DPR 412/93 e DPR 551/99

MODELLO	Potenza termica kW	Portata termica kW	Rendimento a carico nominale		Rendimento al 30% del carico	
			minimo richiesto	misurato	minimo richiesto	misurato
RX 19 CE	22,0	25,0	86,7	88,0	84,0	84,5
RX 26 CE	30,5	34,8	87,0	87,6	84,4	84,8
RX 37 CE	39,1	44,8	87,2	87,3	84,8	85,2
RX 48 CE	48,8	55,0	87,4	88,7	85,1	85,4
RX 55 CE	60,7	69,2	87,6	87,7	85,3	85,8
RX 26 BF	31,0	34,0	87,0	91,1	84,3	92,0
RMG 70 Mk.II	70,1	77,9	87,8	90,1	85,7	87,1
RMG 80 Mk.II	78,7	87,4	87,9	90,0	85,8	87,2
RMG 90 Mk.II	90,0	100,0	88,0	90,0	86,0	87,4
RMG 100 Mk.II	98,6	109,5	88,1	89,9	86,1	87,5
RMG 110 Mk.II	107,9	120,5	88,1	89,5	86,1	86,4
RS 129 Mk.II	129,0	145,9	88,2	88,4	86,3	86,7
RS 151 Mk.II	150,6	170,0	88,4	88,6	86,5	86,9
RS 172 Mk.II	172,2	194,2	88,5	88,7	86,7	87,1
RS 194 Mk.II	193,7	218,2	88,6	88,8	86,9	87,3
RS 215 Mk.II	215,2	242,1	88,7	88,9	87,0	87,5
RS 237 Mk.II	236,5	266,0	88,7	88,9	87,1	87,6
RS 258 Mk.II	257,8	290,0	88,8	88,9	87,2	87,7
RS 279 Mk.II	279,1	313,6	88,9	89,0	87,3	87,8
BITHERM 20/65	22,0	25,0	86,7	88,0	84,0	84,5
BITHERM 26/80	30,5	34,8	87,0	87,6	84,4	84,8
BITHERM 35/80	37,2	42,4	87,1	87,7	84,7	85,3
BITHERM 26/80 BF	31,0	34,0	87,0	91,1	84,3	92,0
DUOGAS 20/40	22,0	25,0	86,7	88,0	84,0	84,5
DUOGAS 26/40	30,5	34,8	87,0	87,6	84,4	84,8
LOGO 22 OF	23,7	26,0	89,7	91,0	87,1	90,6
LOGO 32 - 32/50 - 32/80 OF	31,6	34,8	90,0	90,7	87,5	90,5
MISTRAL 32 - 32/50 - 32/80 - 32/120 AD	31,9	34,3	87,0	93,0	84,5	93,6
KOMBIMAT 26/38 CE	29,0	32,2	86,9	90,0	84,4	86,5
AVANT 30/50 - 30/130	29,0	31,6	86,9	91,8	83,9	90,6
DEWY 30/80 - 30/130	29,3	30,0	92,5	97,7	98,5	106,6
EKO 3 OF - 3 OF PVA	21,2	23,3	89,5	90,9	89,5	92,8
EKO 4 OF - 4 OF PVA	31,6	34,8	89,7	90,9	89,7	92,8
EKO 5 OF	42,3	46,5	89,9	90,9	89,9	92,8
EKO 6 OF	53,1	58,3	90,1	91,4	90,1	92,9
EKO 7 OF	63,8	70,1	90,2	91,1	90,2	92,9
EKO 8 OF	74,2	81,5	90,3	91,1	90,3	92,9
EKO 9 OF	84,7	93,0	90,4	91,1	90,4	93,5
EKO 10 OF	95,2	104,6	90,5	91,1	90,5	93,5
EKO 11 OF	105,8	116,2	90,5	91,1	90,5	93,5
EKO 12 OF	117,0	128,0	90,6	91,7	90,6	93,3

NOTA: I dati sono stati ottenuti secondo le modalità di prova indicate dall'allegato E del DPR 412.



Fonderie Sime S.p.A - Via Garbo, 27 - 37045 Legnago (Vr)
Tel. + 39 0442 631111 - Fax +39 0442 631292 - www.sime.it