

# BRITONY FF

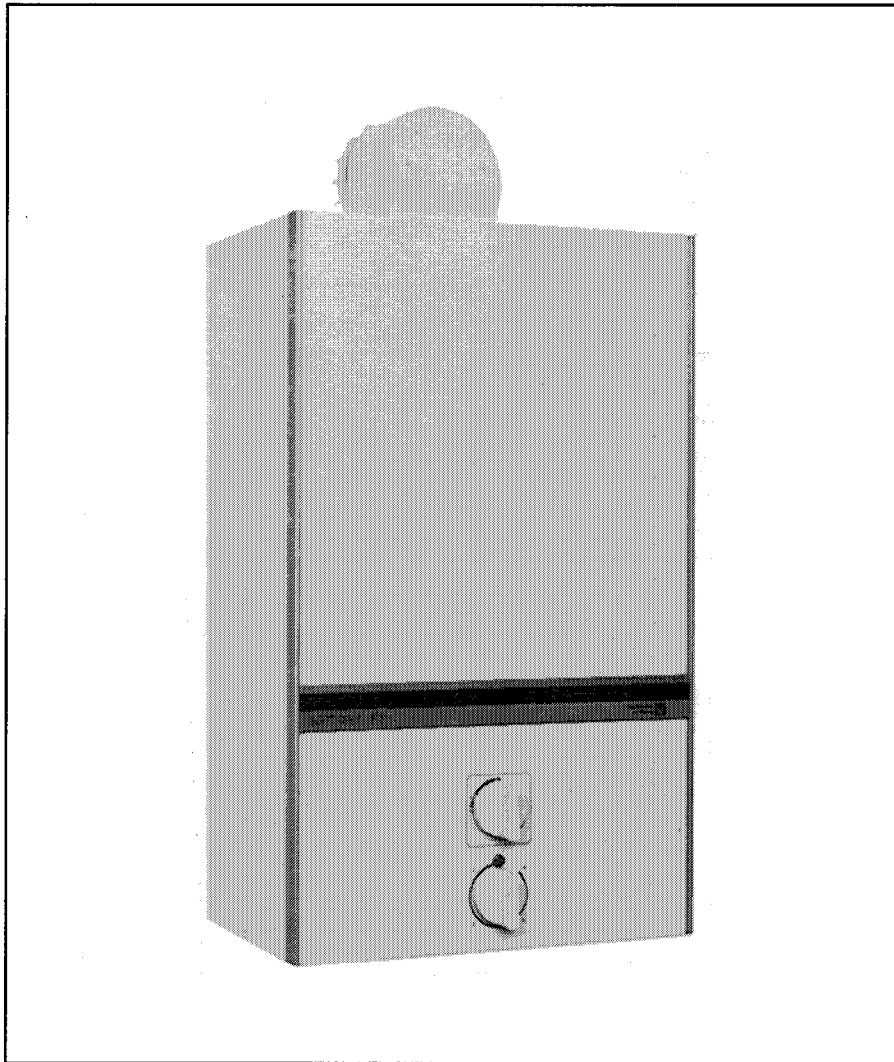

## installation servicing instructions

(leave these instructions adjacent to the gas meter)

1.

**GENERAL**

The BRITONY FF is a fanned draught, balanced flued instantaneous multipoint water heater. The flue is suitable for back outlet, front outlet or to either side. The maximum recommended flue length is 3 m. straight.

The appliance is for connection to a mains cold water supply only.

A permanent electrical connection is required and should be provided by use of a fused spur. If the appliance is installed in a bathroom the fused spur must be external to the bathroom.

When on pilot only the fan runs at 'low speed' increasing the normal speed when there is a demand for hot water. Included are a pressure switch, which operates if the fan stalls or if the flue is obstructed, and a low temperature sensor which will turn off the fan when the appliance is running on pilot only (fan low speed) in the event of low air temperatures likely to cause freezing in the appliance.

1.1

**Guarantee**

The guarantee on this appliance is voidable if it is not installed in accordance with the recommendations made herein as in manner approved by the manufacturer.

1.2

**Dimensions**

	mm	ins.
A	658	25.9
B	395	15.5
C	270	10.6
D	100	4.0
E	40	1.6
F	385	15.15
G	438	17.25
H	778	30.6
J	728	28.6
K	53	2.1
L	55	2.15
M	98	3.8
N	70	2.75
P	285	11.22
R	457	18.0
S	105	4.13
T	199	7.8
V	340	13.4

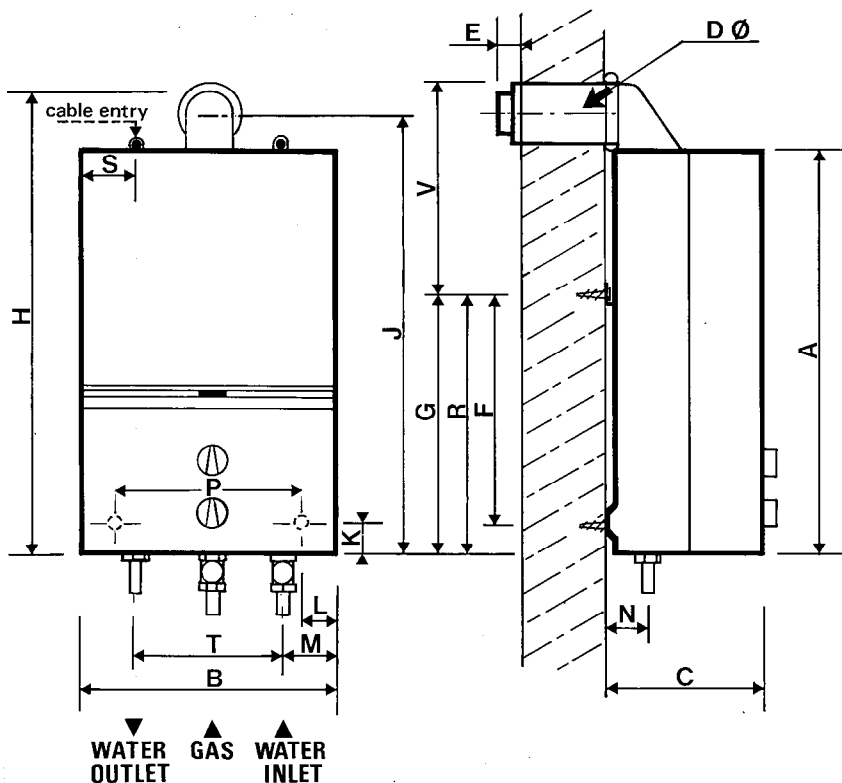

### 1.3

## Technical Data

Heat input nominal	28.6 kW		97583 Btu/h
Heat output nominal	22.4 kW		76565 Btu/h
Gas rate (maximum)	2.67 m <sup>3</sup> /h		94.3 ft <sup>3</sup> /h
Burner pressure	10.9 mbar	4.37 in.w.g.	
Main burner injectors		1.23 mm	
Pilot injectors		0.23 mm	
Water flow rate - raised 50 °C (90 °F)	6.3 l/min		1.4 gpm
Water flow rate - raised 30 °C (54 °F)	10.9 l/min		2.4 gpm
Minimum operating head	7.5 m.		25 ft ( 10 psi)
Maximum operating head	100 m.		328 ft (150 psi)
Electrical Connections - 240 V single phase 50 Hz supply fused 2 amp.			

The minimum water pressure is for the correct operation of the heater only. An additional allowance must be made for the resistance of pipework and fittings particularly where showers and washing machines are used. This should be equivalent to 2 m. (6.5 ft) head.

Water inlet (Compression type fittings)	Right hand connection	15 mm Copper
Water outlet (Compression type fittings)	Left hand connection	15 mm Copper
Gas (Compression type fittings)	Centre connection	15 mm Copper
Height (including flue bend)	778 mm (30.6 in)	
Width	395 mm (15.5 in)	
Depth	270 mm (10.6 in)	
Weight	20 kg. (42 lb)	
Space for fixing - top	50 mm ( 2 in)	
- bottom	178 mm ( 7 in)	
- sides	25 mm ( 1 in)	
- front	600 mm (24 in)	
Hole for wall liner	4 in. diameter.	

The BRITONY FF is supplied in one carton.

### 1.4

## Flue Length

Minimum Wall Thickness 3" 3" (75 mm)

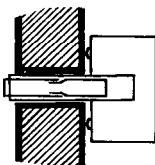
Rear Outlet		Wall thickness	Up to 612.5 mm	Over 612.5 mm
			Delivered with appliance	Extension available Pt N° 61061
<p>Flue tube length = wall thickness + 25 mm            Air inlet tube length = wall thickness + 25 mm</p>				

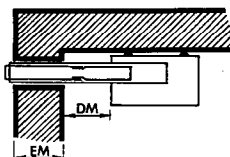
Side Outlet		EM + DM	Up to 500 mm	500 mm to 1400	1401 mm to 2300	2300 mm to 2787
			Deliv. with appliance	1 extn. Pt N° 61061	2 extn. 2 x 61061	3 extn. 3 x 61061
<p>EM = Wall thickness            DM = Distance from wall to case</p> <p>Flue tube length EM + DM + 130 mm            Air inlet tube length EM + DM + 130 mm</p>						

## 2. INSTALLATION REQUIREMENTS

### 2.1 Related Documents

The installation of the heater must be in accordance with the relevant requirements of the Gas Safety Regulations 1972, Building Regulations, IEE Wiring Regulations and the Byelaws of the local water undertaking. It should also be in accordance with any relevant requirements in British Standard Codes of Practice. Detailed recommendations are contained in the following British Standard Codes of Practice :  
 BSCP 331 : Pt. 3 : 1974., BS 5546 : 1979, BS 5440 : Pt. 1 : 1978 and BS 5440 : Pt. 2 : 1976.

### 2.2 Location

The location chosen for the heater must permit the provision of a satisfactory flue termination. The location must also permit adequate space for servicing and air circulation around the heater.  
 The heater may be installed in any room or internal space although particular attention is drawn to the requirements of the IEE Wiring Regulations and, in Scotland, the electrical provisions of the Building Regulations applicable in Scotland, with respect to the installation of a heater in a room or internal space containing a bath or shower.  
 Where the installation of the heater will be in an unusual location special procedures may be necessary and BS 5546 gives detailed guidance on this aspect.  
 A compartment used to enclose the heater must be designed and constructed specifically for this purpose. An existing cupboard or compartment may be used provided that it is modified for the purpose.  
 Details of essential features of cupboard/compartment design are given in BS 5546.

### 2.3 Gas Supply

An adequate gas meter must be connected to the service pipe. Where necessary the local Gas Region of British Gas will arrange for the existing meter to be checked or for a suitable meter to be installed. On no account must any work be carried out on the gas meter other than by the local Gas Region or their specifically authorised contractor.  
 Installation pipes should be fitted in accordance with CP 331 : 3. Pipework from the meter must be of adequate size. Pipes of a smaller size than the gas connection should not be used.  
 The complete installation must be tested for gas soundness.

### 2.4 Siting the Flue Terminal

The standard flue set is suitable for walls having a thickness of 75 mm (3 ins.) to 355 mm (14 ins.). Other flue options are available to a maximum of 3 m (13 ft. 2 ins.) to special order.  
 Detailed recommendations for flueing are given in BS 5440 : Pt. 1. The following notes are intended to give general guidance.  
 The heater must be installed so that the flue terminal is exposed to external air. The heater must NOT be installed so that the terminal discharges into another room or space such as an outhouse or lean-to. It is important that the position of the terminal allows a free passage of air across it all times. The minimum acceptable spacings from the terminal to obstructions and ventilation openings are specified below :

	Terminal Position	Minimum Spacing Fanned Draught
1.	Directly below an openable window, air vent or any other ventilation opening.	300 mm (12 in.)
2.	Below guttering, drain pipes or soil pipes.	25 mm (1 in.)
3.	Below balconies or eaves.	25 mm (1 in.)
4.	Above adjacent ground or balcony level.	300 mm (12 in.)
5.	From vertical drain pipes or soil pipes.	25 mm (1 in.)
6.	From internal or external corners.	25 mm (1 in.)
7.	From a surface facing the terminal.	600 mm (24 in.)
8.	From a terminal facing the terminal.	1200 mm (48 in.)

**Note** – Where the terminal is fitted within 850 mm (34 ins.) of a plastic or painted gutter or 450 mm (18 ins.) of painted eaves an aluminium shield of at least 750 mm (30 ins.) long should be fitted to the underside of the gutter or painted surface.

Where the lowest part of the terminal is less than 2 m. (6.5 ft) above the level of any ground, balcony, flat roof or place to which any person has access and which adjoins the wall in which the terminal is situated must be protected by a guard of durable material (a terminal guard is available from Chaffoteaux Limited) or from Tower Flue Components. Tonbridge 351555.

The air inlet/products outlet duct and the terminal of the heat must not be closer than 50 mm (2 ins.) to any combustible material. Detailed recommendations on the protection of combustible material are given in BS 5440 Pt. 1 : 1978 (Sub-clause 20.1).

**IMPORTANT NOTICE : TIMBER FRAMED HOUSES.** If the appliance is to be fitted in a timber framed building it should be fitted in accordance with the British Gas publication "Guide for Gas Installations in Timber Framed Housing" reference DM2. If in doubt advice must be sought from the local Gas Region of British Gas.

### 2.5 Preparing the Wall

The heater should be installed on a flat non-combustible material which will not reverberate. Whatever the thickness of the wall make a hole 100 mm (4 ins.) in diameter, a core drill would be suitable.  
 For dimensions and clearances see Page 2 and Technical Data Page 3.  
 Slide the wall liner through the wall.

### 2.6 Fitting the Flue Terminal

The flue terminal may be fitted from inside or outside of the building. If fitting from inside the terminal should be fitted into the flue liner and the assembly passed through the hole in the wall. The outside diameter of the terminal is the same as outside diameter of the tube.

### 2.7 Air supply

The heater does not require any purpose provided ventilation unless installed in a compartment. A compartment enclosing a heater requires high and low level openings. These openings must either communicate with a room or internal space or be direct to outside air. The FREE area of the opening must be :

	High level	Low level
Air from room or internal space	258 cm <sup>2</sup> (40 in. <sup>2</sup> )	258 cm <sup>2</sup> (40 in. <sup>2</sup> )
Air direct from outside . . . . .	129 cm <sup>2</sup> (20 in. <sup>2</sup> )	129 cm <sup>2</sup> (20 in. <sup>2</sup> )

## 2.8 Electrical Connections

These appliances must be earthed.

The installation should be undertaken by a competent electrician and should be in accordance with the current edition of the IEE Wiring Regulations.

Particular attention should be paid to cross bonding.

The heater should be provided with a means of isolation. If installed in a bathroom the means of isolation must be external to the bathroom or a double pole cord switch fitted.

A three core cable should be used and a cable of 0.75 mm<sup>2</sup> is considered suitable. The cable should be passed through the clamp on the top of the heater and the clamp tightened to secure the cable. Connection to the heater should be made in accordance with diagram (page 8).

## 2.9 Description of Operation

The controls on the BRITONY FF are comprised of range of thermal, electric and electronic switches. Broadly, the thermal controls are for the pilot flame supervision, the electrical controls are functional switching and the electronic controls act as a security for the functional controls.

The circuit is designed so that, under normal conditions, the fan runs continuously at low speed and automatically changes to high speed when the gas valve opens. If, however, the incoming air temperature approaches 0 °C the integral frost protection thermostat interrupts the low fan speed signal. Under this condition, if there is a demand for hot water, then the fan recommences at high speed. There is an in-built delay circuit to prevent the safety devices operating prematurely.

The pilot can only be established under the control of the thermocouple flame failure circuit after the mains electricity connection is made since it is dependent upon the energising of the relay – RL1.

In the start mode indicated by the solid line, relay RL2 is energised allowing a signal to be passed to relay RL1. This circuit is completed through the normally closed contacts on the pressure switch. At the same time the micro-switch passes a supply to the fan which runs on low speed.

The microswitch is operated by a lever which is actuated by the gas valve as a result of a water flow causing the diaphragm to rise.

When there is a demand the main gas valve opens automatically and the microswitch causes the fan to go to high speed resulting in :

a) the pressure switch to transfer to the normally open (high speed) connection, and

b) relay RL2, now having the same potential across the coil, releases allowing the contacts of SW1 to change over from T to R. The route the indicated by the dotted line Fig. 4. During the switching time relay RL1 is held in by a discharge capacitor thus preventing nuisance pilot outage.

If the air flow is not proved on high speed the circuit is incomplete since the pressure switch does not change over and therefore the flame failure device will operate by interrupting the thermocouple as a result of the failure of the circuit through relay RL1.

Additional security is provided for the condition where, because the linkage is mechanical, the main gas burner is initiated by the microswitch has remained in the low fan speed position.

**n.b.** This circuit does not function when the fan operates at high speed. In this case the ionisation circuit is completed by the flame. A field effect transistor complete the circuit completes and drops out the FFD relay RL1. If the burner is sensed in the low fan speed circuit the appliance fails safe.

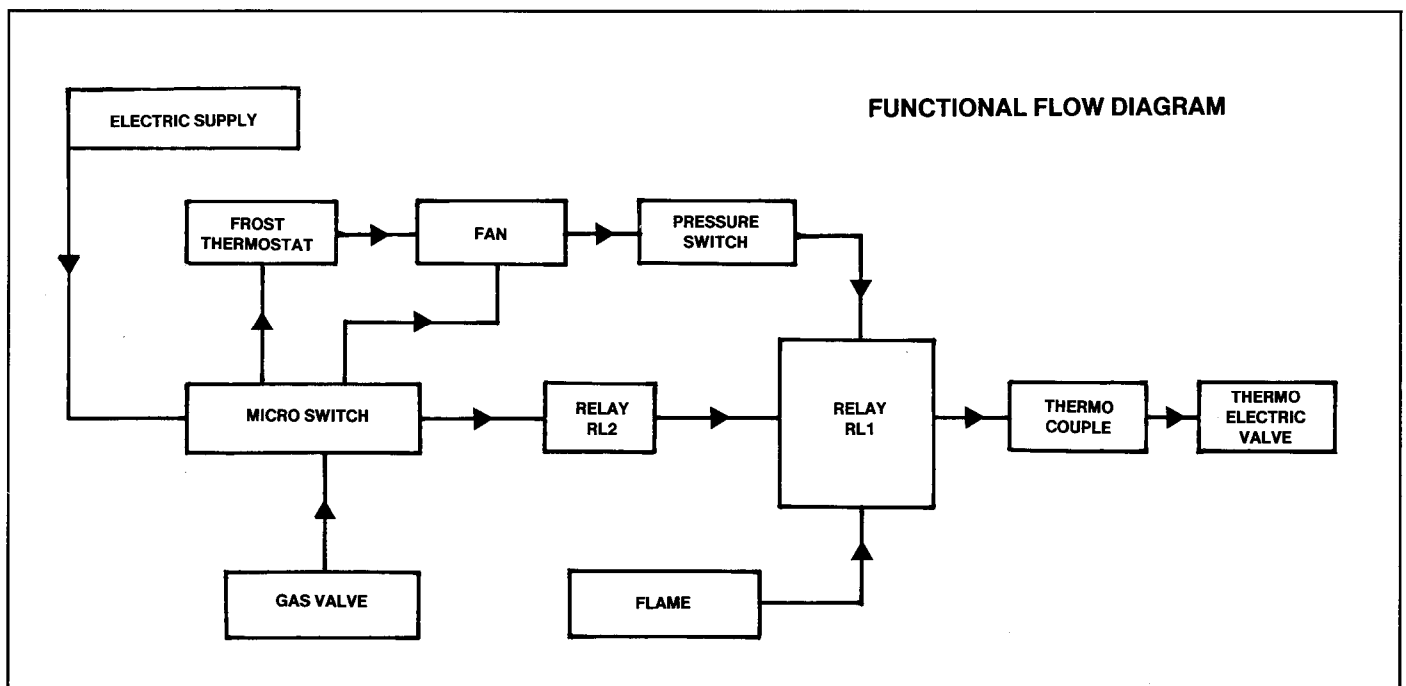

### CIRCUIT DIAGRAM

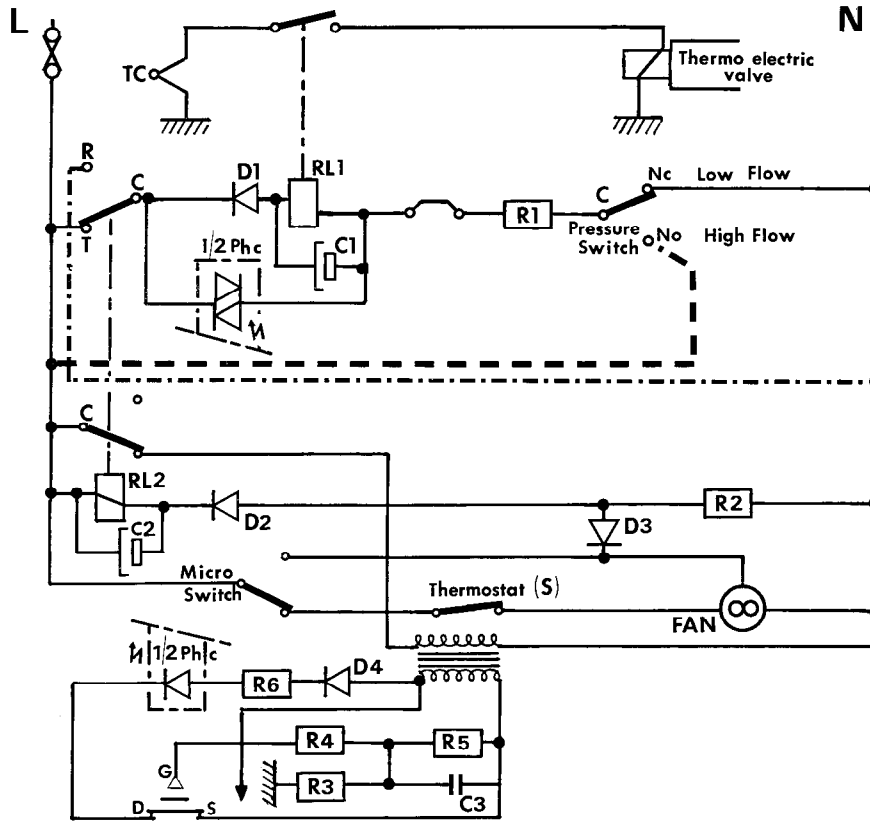

### WIRING DIAGRAM

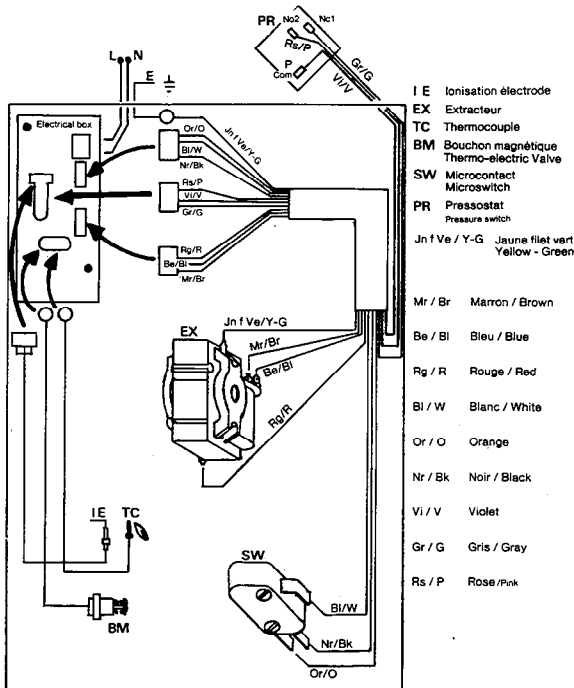

### ELECTRICAL CONNECTION

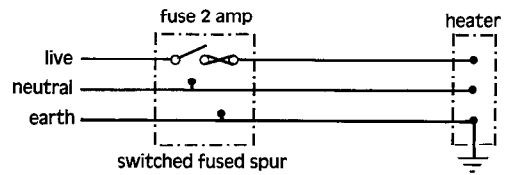

NB : IF HEATER INSTALLED IN A BATHROOM SPUR MUST BE EXTERNAL TO ROOM

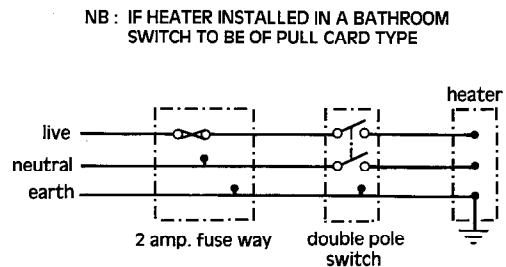

NB : IF HEATER INSTALLED IN A BATHROOM SWITCH TO BE OF PULL CARD TYPE

### 3. INSTALLING THE HEATER

The heater is attached to the wall by a wall bracket and two screws at the bottom.

The bracket and screws are supplied in a box together with the gas and water service taps, gas control knob and temperature selector knob. The box is packed in the appliance case.

#### 3.1 Fitting the heater

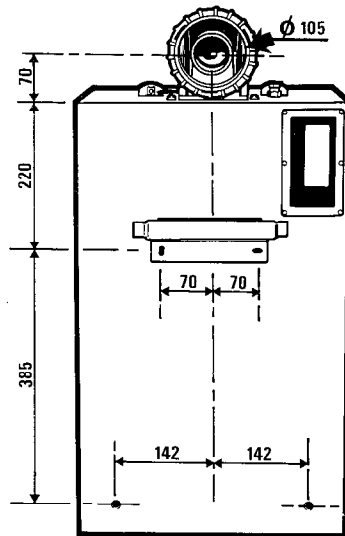

- Remove the front case by unscrewing the four fixing screws positioned at the top bottom and centre of the appliance.
- Ease the front case off the top locating lugs by pulling forward to clear the water section at the base of the appliance.
- Set out and drill hole for flue using a 4 in. core drill.
- Using dimension (V) on Page 3 drill and rawplug the wall and fit bracket to the wall.
- Adjust bracket if necessary to ensure that dimension (V) is maintained along the length of the bracket and finally secure in position.
- Hang the heater on the bracket.
- Mark the two fixings at the bottom of the heater, drill and plug the wall. Secure the heater to the wall using the screws provided.

#### 3.2 Fitting the Flue

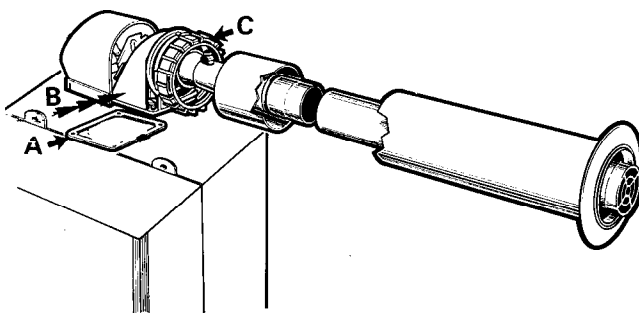

- Measure the wall thickness and cut flue duct and wall liner to length, see 1.4.
- Peel off protective paper from adhesive side of cork gasket A and place on mating side of flue turret B lining up screw holes and press down.
- Assemble flue duct on to flue tube section using rubber sealing ring provided.
- Fit locking ring and O ring overliner C.
- Fit flue duct and turret so that it engages into the terminal.
- Engage locking ring over legs by turning in an anti-clockwise direction viewed from behind turret.
- Pass the assembled flue through the wall.
- Seat the turret onto the top of the heater ensuring the gaskets are in position.
- Secure with 4 screws provided.
- Do not fit turret cover or the front cover until electrical connections have been made and the heater tested for gas and water soundness.

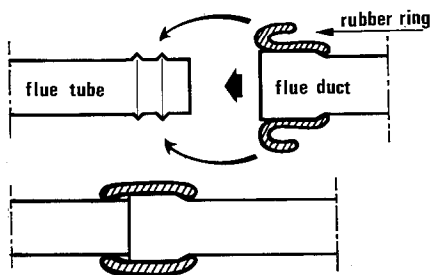

### 3.3

## Gas Connection

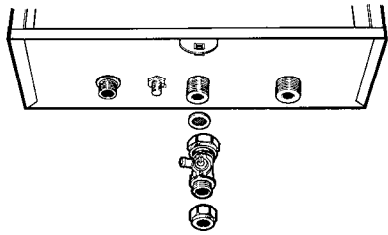

- Remove the plastic cover from the gas inlet which is the centre connection on the bottom of the heater.
- Fit the gas service tap provided using the fine filter washer to seal the connection. Fit the nut and olive on the gas 15 mm gas supply pipe using suitable sealant and tighten.

### 3.4

## Water Connections

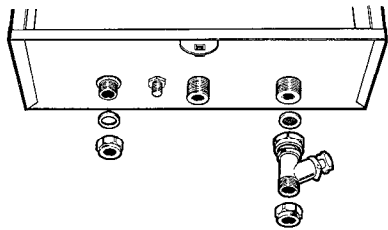

- Remove the plastic covers protecting the water inlet and the water outlet connections.
- Fit the water service tap provided to the right hand connection at the bottom of the heater using the coarse filter washer to seal the connection.
- Fit the nut and olives on the supply and delivery pipes using suitable sealant. The inlet supply to the water service tap and to the outlet delivery side of the heater (left hand connection). The water service tap supplied with the heater incorporates a drain plug.

### 3.5

## Electrical connections

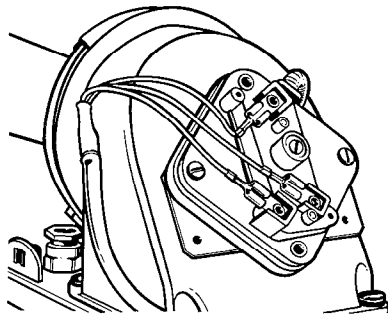

### 3.5.1. Pressure Switch

- Connect the wires at the top of the heater to the pressure switch.
- The **grey** wire is connected to normally closed (NC 1) contact.
- The **pink** wire to the normally open (NO 2) contact.
- The **violet** wire to the common (P) contact.
- Fit the flue bend cover passing the wire through one of the slots provided and securing with the thread forming screws provided.
- See figure.

### 3.5.2. Mains Connection

- Pass 0.75 mm<sup>2</sup> heat resisting cable through cable gland.
- The earth wire (green yellow) must be connected to the earth pillar.
- The live (brown) and neutral (blue) should be connected as indicated into the terminal block.
- Check that component plugs are pushed home.
- Check for continuity, polarity and earthing.

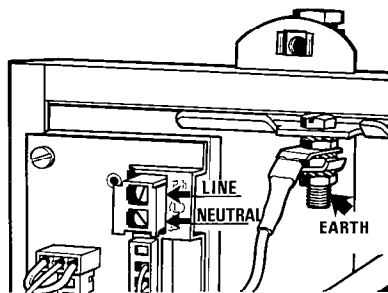

## 4. APPLICATIONS OF THE BRITONY FF

The heater is designed to serve a variety of hot water draw off points including washing machines and showers. The heater can be connected to all hot water draw-off points in the installation. If more than one outlet is open simultaneously the total flow of water cannot exceed that quoted in the Technical Data.

The heater is compatible with most current automatic washing machines but care should be taken to ensure that the machine is capable of accepting water at the design flow rate of the heater. Hot and cold fill machines normally require a hot water temperature of 60 °C (160 °F), the heater producing approximately 6.5 l/min (1.44 gpm) at this temperature. The advice of the washing machine manufacturers should be sought but generally it is only necessary to remove the water flow restrictor (if fitted) in the hot water inlet connection of the machine to obtain a satisfactory heater operation.

Contact Chaffoteaux Limited for details of those machines known to be compatible with the BRITONY FF.

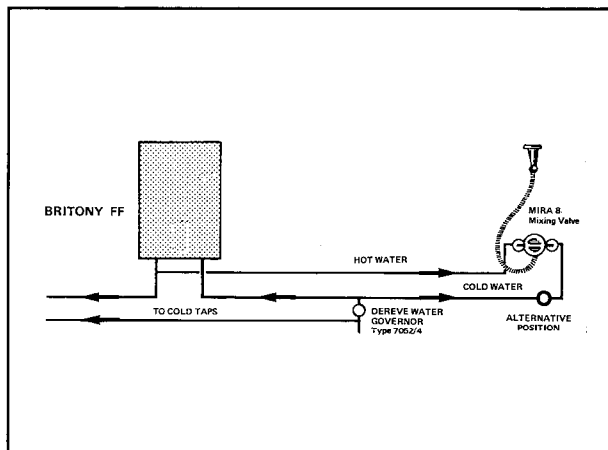

The heater can be used to supply hot water to a separate shower draw-off. The heater should not be used to supply more than one shower mixing valve. The recommended pipework arrangement for a single shower head is shown above. Only those fittings detailed should be used with the heater. Chaffoteaux Limited do not supply the water governor or any shower fittings. For local suppliers of these please contact :

**Water governor** – Dereve (Flow Controls) Limited  
Unit 1, Dudley Road West,  
Tividale, Sandwell, B69 ZPF  
West Midlands - 021 520 1337

**Shower Accessories** – Walker Crossweller and Co. Ltd.  
Whaddon Works, Cheltenham  
Glocs. GL52 5EP  
Tel : 0242 27953

Aqualisa Products Limited  
Horton's Way, London Road,  
WESTERHAM, Kent, TN16 1BT  
Tel : Westerham (0959) 63240

Do not use the heater with push on hand showers that fit over existing hot and cold water taps or with mixer taps unless both supplies come from the same source. Showers forming part of bath mixers are not recommended for satisfactory operation of the appliance.

## 4.1 Pipework

The following notes are for general guidance only.

- (i) The heaters performance may be affected if the installation has old pipework forming dead-legs or air reservoirs. Always ensure that any old pipework is either removed or capped off immediately adjacent to the pipework that will be in use.
- (ii) The size of the pipework between the heater and the various draw-off points should be sized to ensure an adequate flow at all draw-off points when used individually.
- (iii) A check should be made of all stop cocks in the incoming supply and it should be ensured that they are of the fixed jumper pattern. Loose jumpers can be pinned on soldered into position.

## 4.2

A water reservoir is provided on the outlet side of the heat exchanger to limit the water temperature due to « after heat ».

## 5. COMMISSIONING THE HEATER

### 5.1 Putting into Service

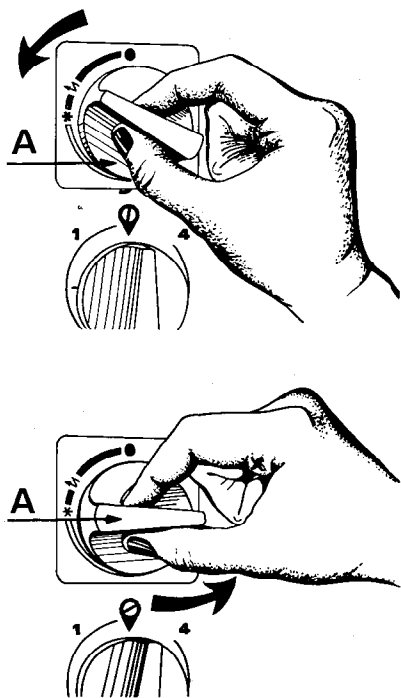

- Open the gas and water service taps beneath the appliance, purge the gas. Turn on an adjacent tap and purge the water side of the installation. Close tap. Check for gas and water soundness at all heater and external pipework connections.
- Fit front cover by locating bottom first and ensuring top of cover locates over bracket. Secure with 4 screws previously removed ensuring plastic washers are in place.
- Fit the gas control knob (A) and light the pilot by turning the knob 90° anti-clockwise. It may be necessary to purge the pilot gas supply, if so, wait a few minutes, return the gas valve to the OFF position and repeat (the pilot supply will only purge when the gas control knob has been turned 90° anti-clockwise).
- Switch on electrical supply, fan will run at low speed.
- Turn the gas control fully anti-clockwise to the main gas position. If the pilot is now extinguished for any reason return the gas control knob to the OFF position and wait approximately 30 seconds for the safety interlock to reset before repeating.

### 5.2 Gas Pressure

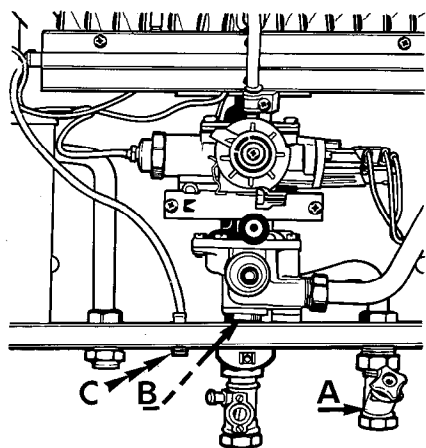

- Turn on an adjacent hot water off point, the heater will now light and the fan draw change to normal speed.
- Test for gas soundness around the heater gas components using a leak detection fluid.
- Check the burner setting pressure at the pressure test (C) point in the base of the appliance after continuous operation for 10 minutes with front cover fitted.
- If the burner setting pressure is not correct, check that the pressure at the gas tap, test point is 20 m,bar (8 in.w.g.) with the appliance operating. If the inlet pressure is not correct, check for any possible blockage or restriction in the pipework to the heater. If the pressure cannot be corrected contact your local gas region. The heat input to the heater is pre-set and non-adjustable.

### 5.3

#### Flame Failure

Check the operation of the flame failure device on the heater by blowing out pilot light. The flow of gas to the pilot will cease and the thermoelectric valve drops out with an audible 'click' within 30 seconds.

### 5.4

#### Slow Ignition

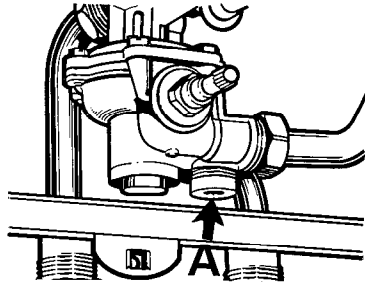

- Check burner ignition which should be smooth and quiet (not explosive).
- If slow ignition requires adjustment. Proceed as in 6.1 to remove front cover.
- Adjust slow ignition 1/4 turn at a time. Refit front cover and test operation. Screwing A out speeds up ignition. Screwing in delays ignition.
- Refit front cover.

### 5.5

#### Handing Over

Hand the User's Instructions to the user or purchaser and instruct in the correct and safe operation of the heater.

Explain to the user or purchaser that if the heater is not to be used for long periods it is recommended that the heater is drained, this is particularly important during the winter months (see servicing instructions for how to drain heater).

Finally, advise the user or purchaser that, for continued efficient and safe operation of the heater it is important that adequate servicing is carried out at intervals recommended by the local gas region.

## 6. SERVICING INSTRUCTIONS

Before commencing any service work :

1. Isolate electrical supply.
2. Turn off gas at gas service tap.
3. Turn off water at water inlet tap.
4. Drain water heater by turning off water service tap opening hot water outlet tap and removing drain plug in the water service tap.

### 6.1

#### Front Casing

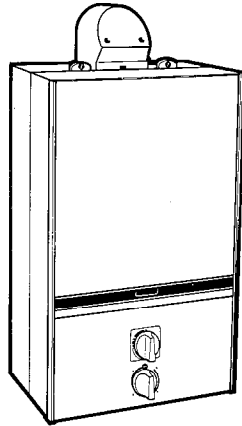

#### To remove :

- Pull off gas control and temperature control knobs.
- Remove four fixing screws (two at top one at the bottom and one centre of the appliance).
- Pull off case easing top forward first over top brackets and pulling forward and down to clear the water section.

### 6.2

#### Burner

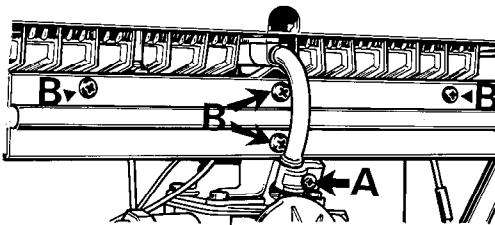

- Remove the combustion chamber front panel as detailed in 6.4.
- Unscrew the pilot tube clamping screw (A) and remove the clamp and screw and pilot tube. Disconnect the pressure test tube from the left hand end of the manifold.
- Remove the burner manifold by unscrewing the four screws (B).
- Unplug ionisation electrode from the electrical box.
- Pull burner head assembly forward to remove taking care not to trap the thermocouple or ignitor wires.
- The burner head should be turned upside down and cleaned by brushing.
- Replace in reverse order making sure that the gasket between the burner manifold and gas section is in place and is in good condition. If necessary replace gasket and ensure that the burner head assembly is correctly located on the two spigots at the rear.

### 6.3

#### Pilot

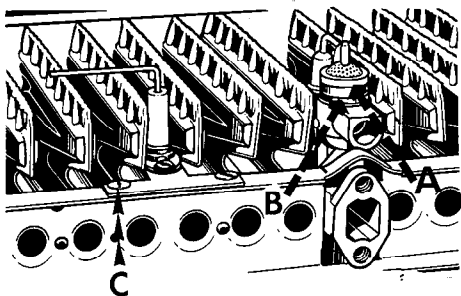

- Remove pilot tube as in 6.2.
- Blow through the tube to remove any dust.
- Unscrew the knurled pilot burner outer ring (A).
- Remove flame retention gauze.
- Unscrew the pilot body (B) with a 15 mm spanner. Clean by brushing and blowing.

DO NOT CLEAN HOLES WITH A WIRE.

- Re-assemble in reverse order ensuring pilot body is screwed down tightly.

**NB :** Where access is difficult it is advisable to remove the combustion chamber front panel as detailed in 6.4.

## 6.4

### Heating Body

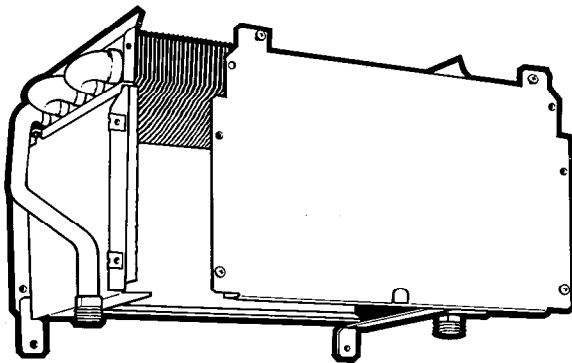
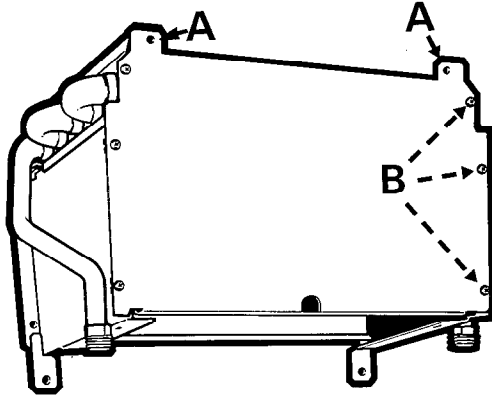

#### a) The heating body can be examined in position :

- Remove two threaded screws which secure the front panel of the combustion chamber skirt to the flue hood (A).
- Remove three self-tapping screws on either side of heat exchanger skirt (B).
- Prior to cleaning the heat exchanger adequate precaution should be taken to protect the pilot burner/gas valve assembly to prevent the ingress of dust etc.
- If additional cleaning is necessary, removal of heat exchanger will facilitate greater access.
- To remove heat exchanger proceed as in 6.4.2.
- To remove heat exchanger.

#### b) To remove heat exchanger

- Turn off the water inlet tap and open an adjacent water draw off point.
- Remove the drain plug from the side of the water inlet tap. Drain water by opening hot tap.
- Remove combustion chamber front panel 6.4.1.
- Remove burner 6.2
- Slide out combustion lining and retain.
- Disconnect the unions on either side of the heat exchanger.
- Remove two screws securing the combustion chamber/heating body assembly to the rear panel.
- Remove heat exchanger and combustion chamber.
- Remove two screws at the rear of the combustion chamber securing the combustion chamber to the heat exchanger.
- Slide heat exchanger forwards.

## 6.5

### Descaling Procedure

Periodically it may be necessary to remove scale deposits from the waterways of the heater to ensure continued and efficient operation.

The frequency of descaling will depend largely on the hardness of the water and your installer or local Region of British Gas should be contacted for advice.

## 6.6

### Main Gas Valve

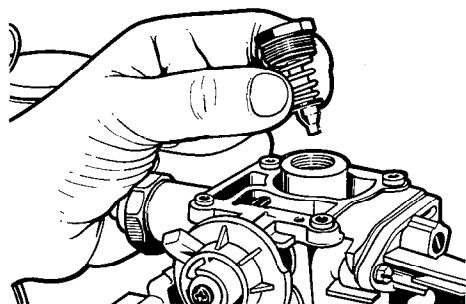

#### To inspect and clean.

- Remove the burner (6.2).
- Disconnect the thermocouple from the thermo electric valve and ignitor lead from the piezo.
- Remove the four screws fastening the top of the gas section to the base and the two screws at the back holding it to the rear case.
- Lift the gas section top off the base.
- Remove the complete gas valve assembly by unscrewing the hexagonal spring retainer from the top of the assembly.
- Remove the spring and gas valve and clean the valve seating.
- Replace facing rubber washer on the gas valve assembly and 'o' ring, if necessary.
- Replace in reverse order, ensuring that the hexagonal spring retaining nut is screwed fully down and the whole assembly is screwed fully down into the gas section.

## 6.7

### Water Governor

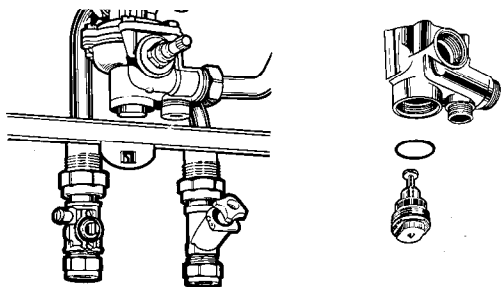

#### To clean

- Turn off the cold water supply to the heater and drain into receptacle.
- Remove the governor situated in the base of the water section.
- Clean the components with water.
- Check that the spring loaded piston moves freely.
- Replace in reverse order.

## 6.8

### Gas and Water Filters

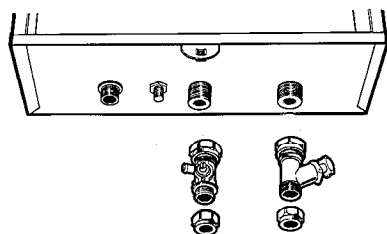

#### Gas and water inlet filters are fitted between the inlet taps and the heater.

- To clean, turn off the taps, unscrew the union nuts attaching the taps to the heater and remove the filters.
- Clean the filters by blowing or washing in water. DO NOT use any solvents.
- Replace ensuring that the coarse filter is fitted in the water inlet and the fine filter in the gas inlet.

## 6.9

### Microswitch

The microswitch operating mechanism is factory set and sealed and should not require adjustment. If the microswitch requires replacement proceed as in Section 7.12/7.13.

## 6.10

### Greasing of Components

Care should be taken during the annual servicing of an appliance to grease the gas valve spindle (see 6.6) and diaphragm spindle (see 7.5). Use either graphited or silicone grease.

## 7 REPLACEMENT OF COMPONENTS

### 7.1 Thermocouple

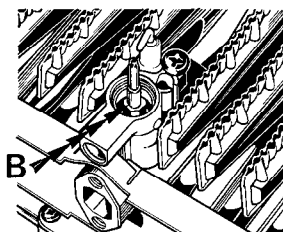
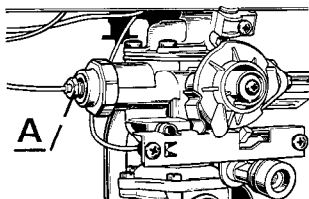

- Remove the burner, see section (6.2).
- Remove the pilot, see section (6.3).
- Trace conductor and disconnect at electrical box.
- Unscrew the thermocouple nut (A) from the thermoelectric valve and remove it from the wire.
- With a 7 mm box spanner, unscrew the nut (B) holding the thermocouple into the gas section.
- Thread the thermocouple and wire up through the gas section.
- Replace in reverse order.

### 7.2 Spark Electrode

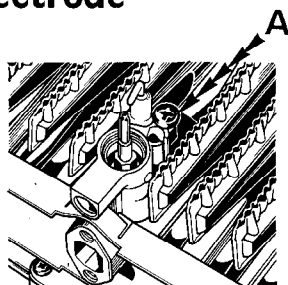

- Remove the burner, see section (6.2).
- Remove the electrode retaining screw (A) with a screwdriver placed inside the heating body skirt.
- Pull off the electrode cable from the piezo cartridge.
- Lift the electrode out of the gas section.
- Re-assemble in reverse order, and note that the slot in the connector on the end of the electrode cable is vertical when pushed onto the cartridge.

### 7.3 Thermoelectric valve

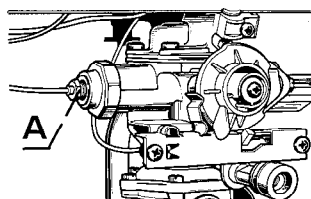

- To replace, remove the thermocouple nut (A).
- Unscrew cap from the side of the gas section and withdraw the thermoelectric valve.

**NOTE** - This heater is fitted with a safety interlock. When the pilot is turned off, the heater cannot be re-lit until the thermocouple cools down and the lighting sequence is repeated.

### 7.4 Water Section Venturi

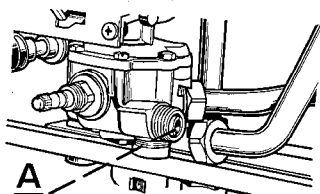

- Drain the heater as in Section (6).
- Disconnect the right hand heating body leg at the water section and remove the venturi (A).
- Clean or replace as necessary and re-assemble in reverse order.

## 7.5

### Diaphragm

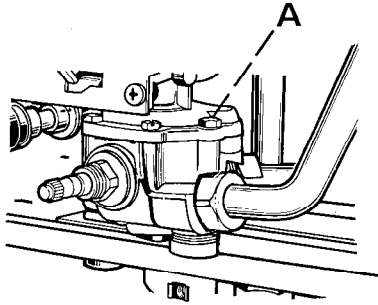

- To replace, turn off the cold water supply and gas.
- Drain the heater by removing the water governor plug situated in the base of the water section.
- Disconnect heat exchanger mains connections.
- Unscrew the six screws (A) holding the water section to the gas section.
- Remove the water section complete with the diaphragm.
- Replace in reverse order – **NOTE** – fit the water governor last. It is easier if the cold water inlet connection is partially engaged before fitting the screws and re-connecting the union nuts.

## 7.6

### Piezo Cartridge

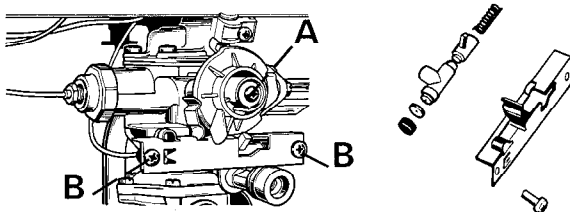

- Pull off the electrode wire from the piezo cartridge.
- Remove the screw holding the gas control cam and remove the cam (A).
- Remove the two screws (B) holding the retaining plate.
- Remove the piezo cartridge and replace if necessary.
- On reassembling the spring must be positioned by means of the locating pins on each end of the spring.

## 7.7

### Heat Input

The heat input is pre-set and non-adjustable.

The heat input and burner pressure should be checked against Table 1.

If the heat input/burner pressure is not correct, check the working pressure at the pressure test point on the gas service tap. This should be 20 mbar (8 in.w.g.).

The gas installation should be examined for any possible blockage if the pressure is incorrect.

## 7.8

### Fan Assembly

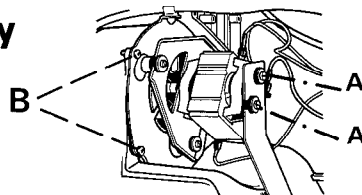

- Pull off spade terminals – noting positions. Remove bracket (A) secured by 4 screws.
- Remove two screws securing fan assembly (B).
- Gently ease away from flue hood disengaging lug at rear of fan.
- Replace in reverse order.

## 7.9

### To Replace Fuse or PCB

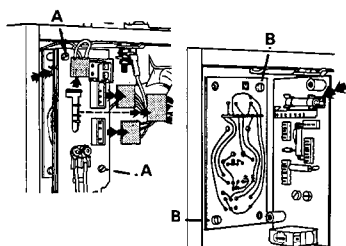

- Isolate electrical supply.
- Remove fan, microswitch, pressure switch and ionisation connectors.
- Remove 2 screws securing cover (A).
- Unplug (8 pin plug) the front PCB from the rear PCB.
- The fuse is on the reverse side of the front PCB.
- Replace in reverse order.
- To remove the other board, remove the remaining two screws (B).

## 7.10

### To replace ionisation probe

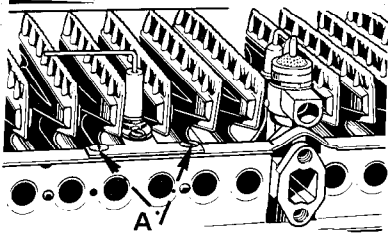

- Remove front case (6.1).
- Remove pilot tube (6.3).
- Remove burner see (6.2).
- The ionisation probe is connected to the burner by two screws (A).
- Disconnect cable at electrical box (see fig. 5).
- Replace in reverse order.

## 7.11

### To replace pressure switch

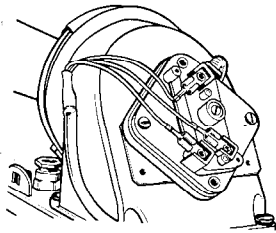

- Isolate electrical supply.
- Remove two screws securing the hood cover.
- Remove spade connections noting position.
- Remove 2 screws securing pressure switch.
- Disconnect low pressure tube noting position.
- Replace in reverse order.

## 7.12

### To check operation of microswitch operating mechanism

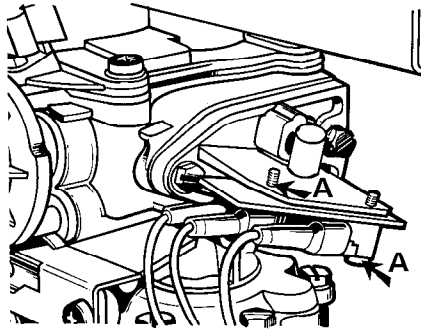

- Remove the front casing, see 6.1.
- Disconnect the electrical supply.
- Remove the two screws securing the microswitch with the appliance at rest the plunger will be flush with the switch plate to switch mating surface.
- With gas and electricity off turn on a draw off tap.
- The plunger should move back 1.5 mm.
- If the plunger moves correctly, replace the microswitch (see 7.12).
- If the plunger does not operate replace the gas and water section (see 7.13).

#### To replace the microswitch

- Remove the front casing (see 6.1)
- Disconnect the electrical supply.
- Remove the three leads from the microswitch.
- Remove the two screws securing the microswitch and insulating backing.
- Replace in reverse order.

## 7.13

### To replace the gas and water section

- Turn off gas supply, isolate water supply and disconnect electrical supply.
- Remove front casing (see 6.1).
- Remove the burner (see 6.2).
- Remove the three leads from the micro-switch.
- Remove the thermocouple lead and conductor lead from the control box.
- Disconnect the union at the rear of the gas section.
- Disconnect the two water connections from the

- water section - mains inlet and water section to heating body.
- Remove the two screws securing the burner base to the rear chassis.
- Withdraw assembly.
- Disconnect the electrode lead from the piezo ignitor.
- Remove the four screws securing the burner base to the gas section.
- Replace in the reverse order.

## 8

**FAULT FINDING CHART FOR BRITONY FF**

	<b>PROBLEM</b>	<b>CAUSE</b>	<b>REMEDY</b>
<b>8.1</b>	<b>Pilot flame does not light</b>	<ul style="list-style-type: none"> <li>i) Gas service tap closed</li> <li>ii) Air in pipe</li> <li>iii) Pilot injector blocked</li> <li>iv) No ignition spark</li> </ul>	Open service tap Purge line Clean or change Check electrode, lead and ignitor
<b>8.2</b>	<b>Poor Pilot Flame</b>	<ul style="list-style-type: none"> <li>i) Pilot injector dirty</li> <li>ii) Wrong injector</li> <li>iii) Pilot head blocked</li> <li>iv) Faulty pilot tube</li> <li>v) Pilot injector loose</li> </ul>	Clean or change Change for correct diameter (0.23) Clean Clean or replace Tighten
<b>8.3</b>	<b>Pilot will not stay alight</b>	<ul style="list-style-type: none"> <li>i) No electrical supply</li> <li>ii) Thermocouple not working</li> <li>iii) Thermocouple valve faulty</li> <li>iv) Gas pressure low/variable</li> <li>v) Terminal wrongly positioned</li> <li>vi) Badly assembled flue</li> </ul>	Check and establish supply Change if output less than 8mv Change valve Check at inlet to heater (see page 10) Re-position heater (see page 4) Refit - check sealing
<b>8.4.1</b>	<b>Main burner does not light</b>	<ul style="list-style-type: none"> <li>i) Gas service tap not open fully</li> <li>ii) Gas pressure low</li> <li>iii) Water rate low</li> <li>iv) Gas valve not opening</li> <li>v) Diaphragm punctured</li> <li>vi) Venturi blocked or loose</li> <li>vii) Gas control tap faulty</li> <li>viii) Slow ignition device screwed fully home</li> </ul>	Open fully Check at manifold and at inlet with the heater running (see page 3) Check if water rate is sufficient (see page 3) Check (v) and (vi) Change diaphragm Check venturi Check operation of User's gas control tap Adjust - see 5.4
<b>8.4.2</b>	<b>Burner goes out on hot water demand</b>	<ul style="list-style-type: none"> <li>i) Microswitch sticking</li> <li>ii) Fan not switching to high speed</li> <li>iii) Pressure switch defective</li> <li>iv) High pressure tube detached</li> <li>v) Flue blocked</li> </ul>	Replace Check microswitch adjustment see p. 17 Replace Refix Check and clear
<b>8.5</b>	<b>Explosive Ignition</b>	<ul style="list-style-type: none"> <li>i) Pilot too small</li> <li>ii) Slow ignition not adjusted</li> </ul>	Check pilot tube and injector Check and adjust (see page 11)
<b>8.6</b>	<b>Gas control tap stiff (User's)</b>	<ul style="list-style-type: none"> <li>i) Grease dried</li> <li>ii) Operating mechanism replaced incorrectly</li> </ul>	Clean and regrease Refit

**FAULT FINDING CHART FOR BRITONY FF**

	<b>PROBLEM</b>	<b>CAUSE</b>	<b>REMEDY</b>
<b>8.7</b>	<b>Low Water Temperature</b>	<ul style="list-style-type: none"> <li>i) Water rate too high</li> <li>ii) Insufficient gas flow</li> <li>iii) Water governor sticking</li> <li>iv) Incorrect venturi</li> <li>v) Main burner injector dirty</li> </ul>	Check water governor Check rate and if user's tap is open Remove and clean or replace Replace (3.65 mm) Clean or replace
<b>8.8</b>	<b>Burner stays on</b>	<ul style="list-style-type: none"> <li>i) Air in pipework</li> <li>ii) Gas valve stays open</li> <li>iii) Dirt on gas valve facing</li> <li>iv) Dirt or foreign matter in water section</li> <li>v) Loose jumper on house stop cock tap</li> </ul>	Check for dead legs Clean and grease gas spindle Strip and clean gas valve  Clean water section Replace water stop tap or pin down jumper
<b>8.9</b>	<b>Yellow Flames – Soot Formed</b>	<ul style="list-style-type: none"> <li>i) Heating body fins blocked</li> <li>ii) Primary air supply restricted</li> <li>iii) Wrong injectors</li> <li>iv) Fan speed incorrect</li> </ul>	Remove heating body and clean Check burner manifold and clean Check injector sizes Check and replace if necessary
<b>8.10</b>	<b>Unstable Flame</b>	<ul style="list-style-type: none"> <li>i) Water in gas line</li> <li>ii) Faulty flue</li> </ul>	Purge Check terminal position and flue ducts
<b>8.11</b>	<b>Heating Body Noise</b>	<ul style="list-style-type: none"> <li>i) Scale</li> <li>ii) Excessive gas</li> <li>iii) Insufficient water flow</li> </ul>	Descale heating body Check gas pressure (see page 10) See below
<b>8.12</b>	<b>Insufficient Water</b>	<ul style="list-style-type: none"> <li>i) Water service tap closed</li> <li>ii) Blocked venturi</li> <li>iii) Low water pressure</li> <li>iv) Water governor faulty</li> <li>v) Water governor sticking</li> <li>vi) Foreign matter in water section</li> <li>vii) Water filter blocked</li> </ul>	Check it is fully opened Remove and clean venturi Check water pressure Change governor Remove and clean or replace Remove and clean Remove and clean/replace

Imp. Chaffoteaux et Maury  
Réf. 91220-139 - 6/84

---

**Chaffoteaux  
et Maury** 

Chaffoteaux Ltd, Concord House, Brighton Road, Salfords, Redhill, Surrey RH1 5DX. Telephone: Horley (02934) 72744. Telex: 87378.

ESP011